



with TYPHON[®] Payload

Sound Distraction System

ODYSSY
COMPATIBLE

NON-LETHAL, RELOADABLE SOUND DISTRACTION PAYLOAD SYSTEM WHICH CAN BE HOOKED TO ODYSSY COMPATIBLE sUAV/sUGV

Additional advanced technologies are often required to successfully achieve tactical objectives in complex under-roof environments. For such situations, Sky-Hero sUGV and sUAV can increase their operational capabilities by carrying dedicated payloads.

Typhon's sound distraction payload provides the operator with 5 single shots or a 5 rounds savlo; each measured at 165+Db and assists with tactical entry, quick deployments, etc.

The control software for this payload is fully integrated into our Odyssey compatible controller, **GCS MkII**.

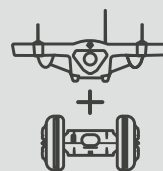

Fits All Devices

The payloads can be used indiscriminately on both unmanned vehicles, **Loki MkII** and **Sigyn MkI**



Plug and Go

Easy to install without tools and immediately operational thanks to Sky-Hero self adaptative algorithms and control features



Non-Lethal

Non-lethal distraction device which negate the risks associated with conventional pyrotechnical devices



Light Design

Specifically designed to be hooked onto mobile platforms where weight and unnecessary complexity is kept to a minimum.

#1 SKY-HERO PAYLOAD CRADLE & VEHICLES HOOKING

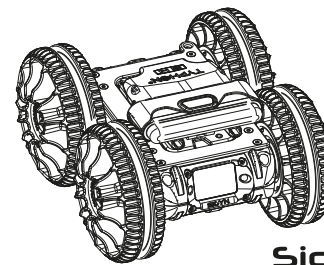
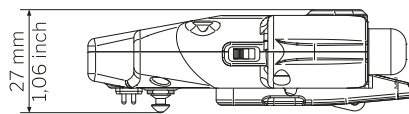
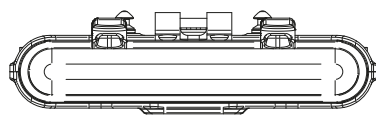

Sigyn[®]

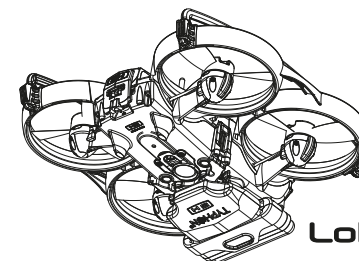
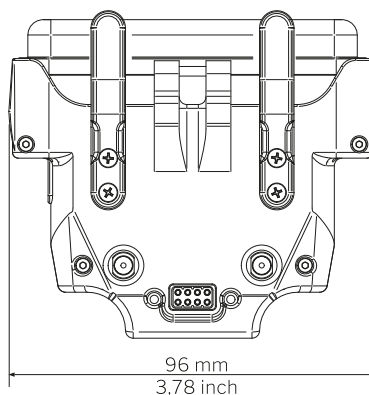
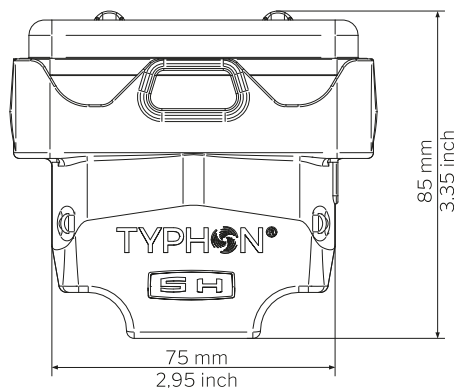

Loki[®]

Weight sUAV Hook 26 g | 0,06 lb Weight Cradle 86 g | 0,19 lb Body material Aluminium 7075-T6 Aviation Grade

#2 TYPHON'S DETONATION CARTRIDGE

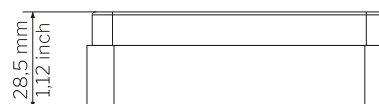
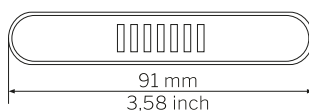

Weight 79 g | 0,17 lb Body material Black Anodised Aluminium 6082 Output 5X 165dB+(A) measured at 1 m

Same sound effect as a conventional percussion grenade or an automatic rifle

#3 IN OPERATION

The system can be initiated with a trigger supplied directly from the **GCS MkII** operator or via an additional Trigger Remote system, wired to the GCS.

The fully integrated GCS software allows for operator selection of single event or burst initiation of the **Typhon distraction cartridge** to provide maximum operational flexibility. Cartridges are easily and quickly inserted/released by the operator with no tools nor external cables requiring connection.

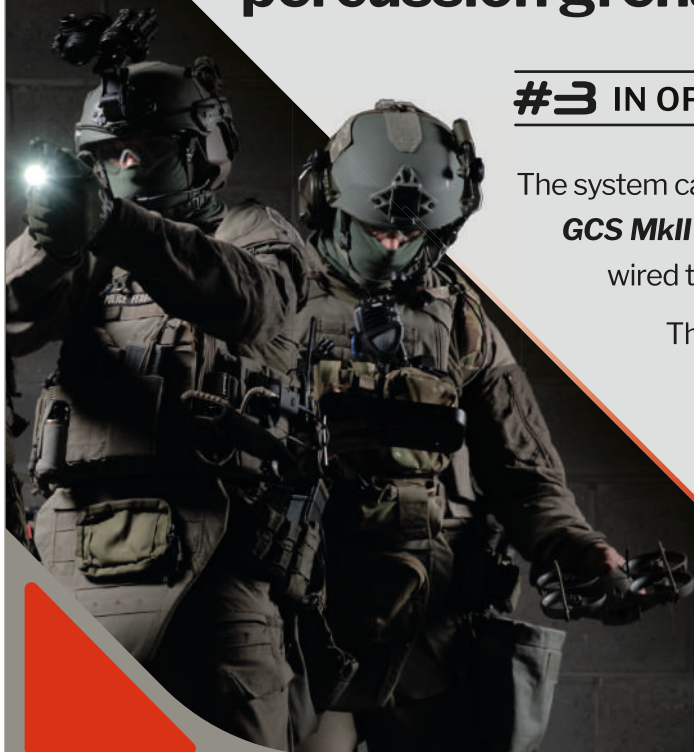

GET IN TOUCH

contact@sky-hero.com
www.sky-hero.com

12 Allée de la Recherche
B-1070 Brussels - BELGIUM

in company/sky-hero-sa
yt SKY-HERO

