

# TEAL 2

## Small Unmanned Aircraft System

### OPERATOR'S MANUAL

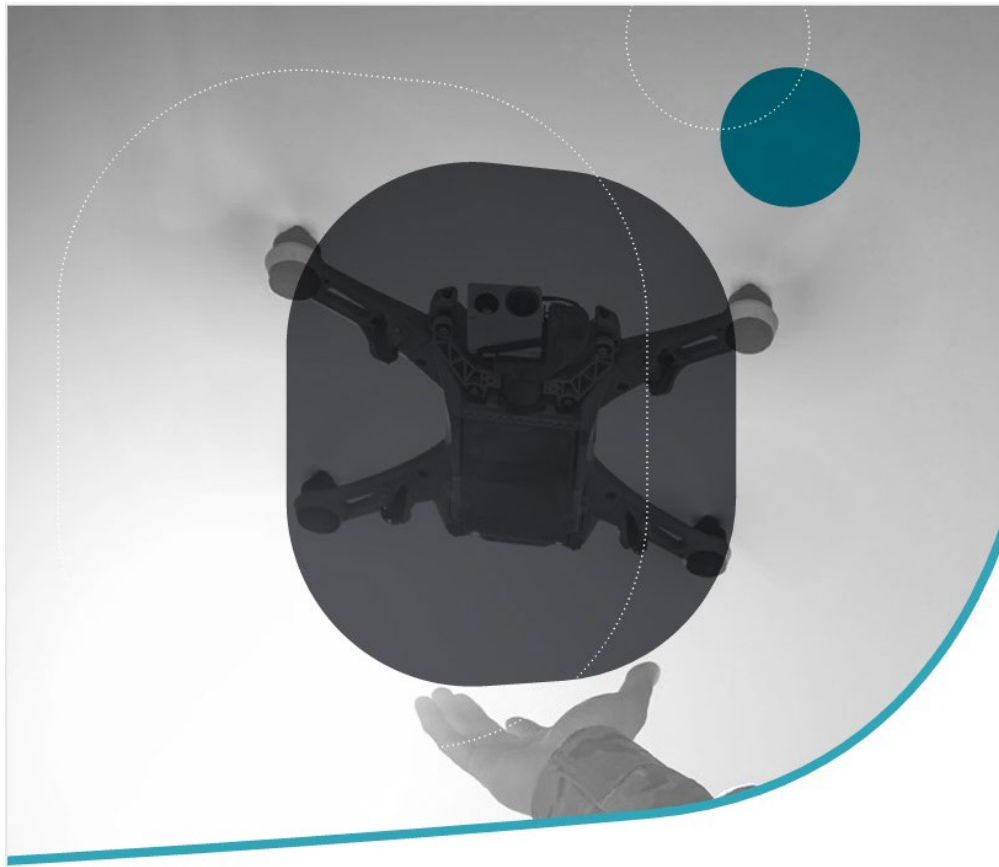

Teal Part # 60083  
Revision C  
8 September 2023



## Overview

This manual covers the following Teal products:

- Teal 2 Small Unmanned Aircraft System (Teal 2)
- Teal Air Control Ground Station (TAC)
  - Ground control station (GCS)
- Teal Air Control (TAC) Software and Applications
  - Teal QGroundControl (Teal QGC) Software App
  - Teal TAC Settings Software App
  - Teal Updater Software App
  - Teal Documentation Software App
- Teal Performance Battery Pack
- Teal Battery Charger and Power Supply

The Teal 2 and TAC quick start guides are included in the Teal 2 hard case.

Find the online quick start guides at: <https://tealdrones.com/support/quick-start-guides/>

Or scan this QR code:



## WARNINGS, CAUTIONS, AND NOTES

Observe identified warnings and cautions for operating procedures before attempting to operate any equipment. Follow safety guidelines to prevent personal injury, damage to equipment, or Federal Aviation Administration (FAA) violations.



**WARNING:** An operating procedure or practice which, if not correctly followed, could result in personal injury or loss of life.



**CAUTION:** An operating procedure or practice which, if not strictly observed, could result in damage to, loss of, or destruction of equipment, data, or surrounding property.



**Note:** An operating procedure, condition, etc., which is important or helpful to highlight.



**SECURITY:** An operating procedure, condition, etc., which is important or helpful to highlight for cyber security best practices.

# TABLE OF CONTENTS

<b>TABLE OF CONTENTS</b>	<b>2</b>
<b>1. KIT CONTENTS</b>	<b>7</b>
1.1. TEAL 2 KIT CONTENTS	7
TEAL AIR CONTROL KIT CONTENTS	7
<b>2. COMPONENT OVERVIEW</b>	<b>8</b>
2.1. AIR VEHICLE OVERVIEW	8
2.2. REGISTER THE AV	9
2.3. TAC CONTROLS OVERVIEW	9
<b>3. GETTING STARTED</b>	<b>10</b>
3.1. ABOUT THE BATTERY PACKS	10
3.2. ABOUT THE BATTERY CHARGER	10
3.3. BATTERY CARE	10
3.4. BATTERY STATUS	11
3.5. CHARGE THE BATTERY PACKS	12
3.6. PREPARE THE VEHICLE FOR FLIGHT	12
3.7. PREPARE THE TAC	14
3.8. POWER ON THE TAC	15
3.9. POWER ON THE AV	15
3.10. THE TAC APPLICATIONS	16
3.11. CONNECT TO WIFI FOR CORRECT TIME	16
3.12. PAIR AND CONNECT THE TAC WITH THE TEAL 2	16
<b>4. FLY VIEW OVERVIEW</b>	<b>17</b>
4.1. FLY VIEW MAP OVERVIEW	18
4.2. FLY VIEW MAIN TOOLBAR	18
4.2.1. VIEW-SELECT MENU	18
4.2.2. PAIRED VEHICLE IDENTIFIER	19
4.2.3. FLIGHT MODE INDICATOR	19
4.2.4. ARMED AND DISARMED STATUS	19
4.2.5. RID STATUS INDICATOR ICON	19
4.2.6. RID EMERGENCY DECLARATION ICON	19
4.2.7. GPS STATUS ICON	19
4.2.8. RADIO CONTROL (RC) RECEIVED SIGNAL STRENGTH INDICATOR (RSSI) ICON	20

4.2.9.	BATTERY ICON	20
4.2.10.	AIR VEHICLE MESSAGES ICONS	20
4.3.	FLY TOOLS OVERVIEW	21
4.4.	CUSTOMIZING PERSONAL SETTINGS	21
4.5.	DOWNLOADING MAPS	23
4.6.	MISSION PLANNING	24
4.6.1.	PROGRAMMING A SURVEY MISSION	25
4.6.2.	PROGRAMMING A GEOFENCE	26
4.6.3.	PROGRAMMING A RALLY POINT	27
4.7.	VEHICLE SETUP	27
4.7.1.	BUTTON & JOYSTICK SETUP	27
4.7.2.	SAFETY SETTINGS SETUP	27
4.7.3.	ENABLE PHOTO SETTINGS INSTRUCTIONS	29
<b>5.</b>	<b>FLIGHT MODES</b>	<b>29</b>
5.1.	POSITION MODE	29
5.2.	MANUAL MODE	30
5.3.	ALTITUDE MODE	30
5.4.	MISSION MODE	30
5.5.	ARM & EMERGENCY DISARM	31
5.6.	DEFAULT CONTROLS	31
5.7.	STEALTH MODE	32
5.8.	PRE-FLIGHT FLIGHT SAFETY	33
5.8.1.	FLIGHT RESTRICTIONS & REGULATIONS	33
5.8.2.	BEST PRACTICES	33
5.8.3.	IN-FLIGHT EMERGENCY PROCEDURES	33
5.9.	SYSTEM CAPABILITIES / OPERATING LIMITATIONS	34
5.10.	PRE-FLIGHT CHECKLIST	35
5.10.1.	OPERATIONS CHECKLIST	35
5.10.2.	FUNCTION CHECK PROCEDURES:	37
5.10.3.	COLD WEATHER OPERATIONS	39
5.10.4.	HOT WEATHER OPERATIONS	39
<b>6.</b>	<b>ARMING &amp; TAKEOFF</b>	<b>39</b>
6.1.	ARMING THE DRONE	39
6.2.	TAKEOFF	39
<b>7.</b>	<b>IN-FLIGHT</b>	<b>40</b>
7.1.	DEFAULT CONTROLS	40
7.2.	FLY VIEW DETAILS	41

7.2.1.	SCREEN OVERVIEW	41
7.2.2.	CONFIRMATION SLIDER	41
7.2.3.	COMPASS HEADING	41
7.3.	INSTRUMENT PANEL OVERVIEW	42
7.4.	CAMERA CONTROL PANEL	43
7.2.4.	PHOTO MODE	43
7.2.5.	VIDEO MODE	43
7.5.	GIMBAL CONTROL PANEL	45
7.5.1.	GIMBAL CONTROL CIRCLE	45
7.5.2.	ZOOM IN / ZOOM OUT CONTROLS	45
7.6.	PHOTOS SCREEN	46
7.6.1.	ENABLE PHOTO SETTINGS INSTRUCTIONS	46
7.6.2.	PHOTO SCREEN SETTINGS	46
7.6.3.	TAKING A PHOTO	47
7.6.4.	DELETING A PHOTO	47
7.6.5.	VIEWING A PHOTO & METADATA	48
<b>8.</b>	<b>LANDING &amp; DISARMING</b>	<b>48</b>
8.1.	LAND	48
8.2.	RETURN TO LAUNCH (RTL)	49
8.3.	EMERGENCY STOP AND DISARM	49
<b>9.</b>	<b>POST-FLIGHT</b>	<b>49</b>
9.1.	FLIGHT LOGS	50
9.2.	DOWNLOAD FLIGHT LOGS: TEAL 2 → TAC	50
9.3.	TRANSFER LOG FILES: TAC TO REMOVEABLE USB-C DEVICE	50
9.4.	TRANSFER LOG FILES: TAC TO PC	51
9.5.	TRANSFER MEDIA: SD CARD DRONE TO PC	51
9.6.	TRANSFER PHOTOS: TAC TO USB-C DEVICE	52
9.6.1.	TRANSFER MEDIA FROM THE GCS TO A PC	52
9.7.	CLEARING MEDIA	52
<b>10.</b>	<b>POST-INCIDENT REPORT PROCEDURES</b>	<b>52</b>
10.1.	IMMEDIATE POST-INCIDENT PROCEDURES	52
10.2.	DOCUMENTING YOUR INCIDENT REPORT	53
10.3.	FILE AN ACCIDENT REPORT	53
<b>11.</b>	<b>TEAL 2 Teal 2 DETAILS</b>	<b>54</b>
11.1.	ARCHITECTURE & RATIONALE	54
11.1.1.	TEAL 2 SYSTEM POWER	54
11.1.2.	ANTENNAS	54

11.1.3.	ROTOR ARMS	54
11.1.4.	PROPELLER MOTORS	54
11.1.5.	PROPELLER ASSEMBLIES	54
11.1.6.	MULTI-FUNCTION BUTTON	54
11.1.7.	RESET/ FACTORY RESTORE BUTTON	54
11.1.8.	TIME OF FLIGHT SENSOR	55
11.1.9.	STOCK PAYLOAD	55
11.1.10.	MICRO SD CARD SLOT	55
11.1.11.	AUXILIARY LIGHTING	56
11.1.12.	AUXILIARY LIGHTING PLACEMENT	56
11.1.13.	REMOTE IDENTIFICATION	56
11.1.14.	DISCONNECTING A PAIRED VEHICLE FROM THE TAC	57
11.1.15.	UNPAIRING THE SYSTEM	57
11.2.	BINDING THE VEHICLE AND TAC	57
11.2.1.	PAIRING ADDITIONAL VEHICLES	58
11.3.	CALIBRATING THE DRONE	58
11.3.1.	CALIBRATING THE COMPASS	59
11.3.2.	CALIBRATING THE GYROSCOPE	59
11.3.3.	CALIBRATING THE ACCELEROMETER	59
<b>12.</b>	<b>TEAL AIR CONTROL (TAC) DETAILS</b>	<b>59</b>
12.1.	ARCHITECTURE & RATIONALE	59
12.1.1.	SERVICEABILITY	59
12.1.2.	RF COMMUNICATION / RADIO MODEM	60
12.1.3.	LAN / DRONE	60
12.1.4.	I / O	60
12.1.5.	SAMSUNG TABLET	60
12.1.6.	TAC SYSTEM POWER	60
12.1.7.	TABLET POWER	60
<b>13.</b>	<b>SYSTEM SOFTWARE DETAILS</b>	<b>60</b>
13.1.	ACCESSING THE APPS	60
13.2.	TEAL QGC APP	60
13.2.1.	GENERAL SETTINGS	61
13.2.2.	MICROHARD SETTINGS	63
13.2.3.	MAVLINK SETTINGS	64
13.3.	TEAL SETTINGS APP	65
13.4.	TEAL TAC SETTINGS APP	65

13.5.	TEAL DOCUMENTATION APP	65
13.6.	TEAL UPDATER APP	65
13.6.1.	UPDATING SOFTWARE/FIRMWARE	65
<b>14.</b>	<b>BATTERY PACK &amp; CHARGER DETAILS</b>	<b>67</b>
14.1.	ARCHITECTURE & RATIONALE	67
14.1.1.	BATTERY LED INDICATORS	68
14.2.	TEAL BATTERY CHARGER	69
14.3.	CHARGER EXTERNAL POWER SUPPLY	69
<b>15.</b>	<b>MISCELLANEOUS</b>	<b>70</b>
15.1.	PACKAGING, SHIPPING & LABELING SPECIFICATIONS	70
15.1.1.	PACKAGING & SHIPPING	70
15.1.2.	LABELING	70
15.2.	PATENTS & TRADEMARKS	70
15.3.	ELECTRONIC VERSION	71
<b>16.</b>	<b>APPENDICES</b>	<b>72</b>
<b>17.</b>	<b>TROUBLESHOOTING</b>	<b>73</b>
<b>18.</b>	<b>FIELD MAINTENANCE &amp; SCHEDULE</b>	<b>79</b>
18.1.	FIELD REPLACEABLE PARTS	79
18.2.	MAINTENANCE SCHEDULE	79
18.2.1.	AFTER 10 FLIGHT HOURS OR AS NEEDED	79
18.2.2.	AFTER FLIGHT MAINTENANCE OR AS NEEDED	79
18.3.	ROTOR ARM REPLACEMENT	79
18.3.1.	ARM REPLACEMENT INSTRUCTIONS	79
18.4.	CAMERA AND GIMBAL PAYLOAD REPLACEMENT	80
18.4.1.	CAMERA & GIMBAL REPLACEMENT INSTRUCTIONS	80
18.4.2.	SYSTEM CHECKOUT	81
18.5.	PROPELLER REPLACEMENT	81
18.5.1.	PROPELLER REPLACEMENT INSTRUCTIONS	82

# 1. KIT CONTENTS

## TEAL-BRANDED HARD CASE

### CONTENTS:

- 1x TACTICAL DRONE CASE
- 1x TEAL 2 sUAS
- 2x CLOCKWISE PROPELLERS
- 2x COUNTERCLOCKWISE PROPELLERS
- 1x GIMBALED FLIR HADRON EO / IR CAMERA
- 1x GIMBAL / CAMERA PROTECTIVE COVER
- 1x QUICK START GUIDE

## FIELD REPAIR KIT

### CONTENTS:

- 1x 128 GB MICRO SD CARD
- 1x TORX T8 SCREWDRIVER
- 6x TORX ARM ATTACHMENT SCREWS
- 1x CLOCKWISE ROTOR ARM
- 1x COUNTERCLOCKWISE ROTOR ARM
- 2x CLOCKWISE PROPELLER ASSEMBLIES
- 2x COUNTERCLOCKWISE PROPELLER ASSEMBLIES
- 1x QUICK REFERENCE CHECKLIST

## INCLUDED BUT PACKAGED SEPARATELY:

- 2X TEAL PERFORMANCE BATTERY PACKS
- 1X BATTERY CHARGER POWER SUPPLY w/ AC POWER CORD
- 1X BATTERY CHARGE ADAPTER



## TEAL AIR CONTROL KIT CONTENTS

## TEAL-BRANDED HARD CASE

### CONTENTS:

- 1x TAC & INTERNAL RADIO PER TAC SKU
- 1X USB3 DATA CABLE
- 1X TAC 4-POINT HARNESS KIT
- 1X TAC HARNESS INSTRUCTION CARD

## INCLUDED BUT PACKAGED SEPARATELY:

- 2X TEAL PERFORMANCE BATTERY PACKS
- 1X BATTERY CHARGER POWER SUPPLY w/ AC POWER CORD
- 1X BATTERY CHARGE ADAPTER





## 2. COMPONENT OVERVIEW

### 2.1. AIR VEHICLE OVERVIEW

The following diagram illustrates the major components of the AV.

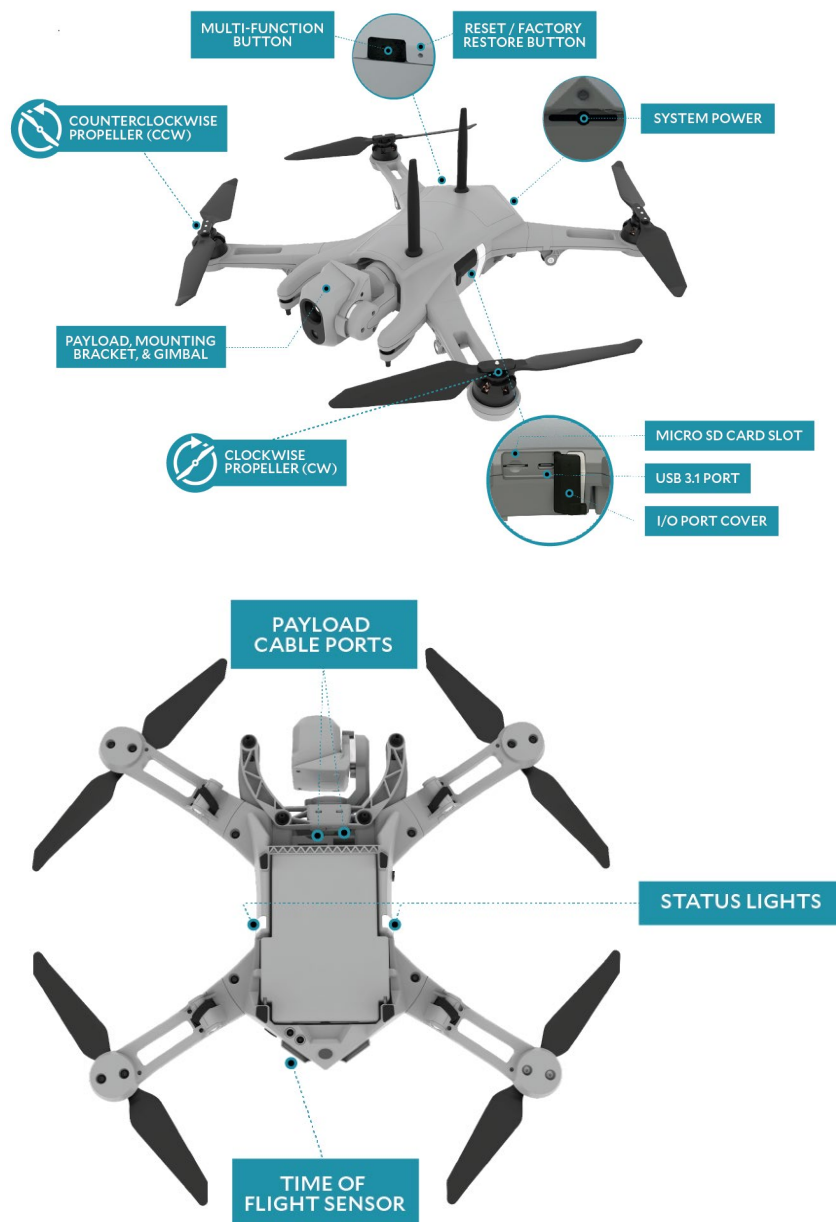

## 2.2. REGISTER THE AV

The air vehicle is designed and tested in accordance with 14CFR Part 89 as a standard Remote Identification (RID) UAS.

Use the RID serial number to register the Teal 2 with the FAA. Locate the RID serial number on the bottom of the Teal 2. Enter the RID serial number in the serial number field on the FAA registration application. Do not use the manufacture serial number.

## 2.3. TAC CONTROLS OVERVIEW

The TAC has a set of left and right buttons, controls, and ports on the front, rear, and top panels. The left and right sets on the top panel each include a joystick, a 4-position switch, and a push button. The left and right-hand sets on the bottom panel each include two push buttons. The front panel includes a left and right-hand push button, each protected with a guard door to prevent accidental actuation. The user can program the controls to suit their needs. The default programmed functions are shown below.

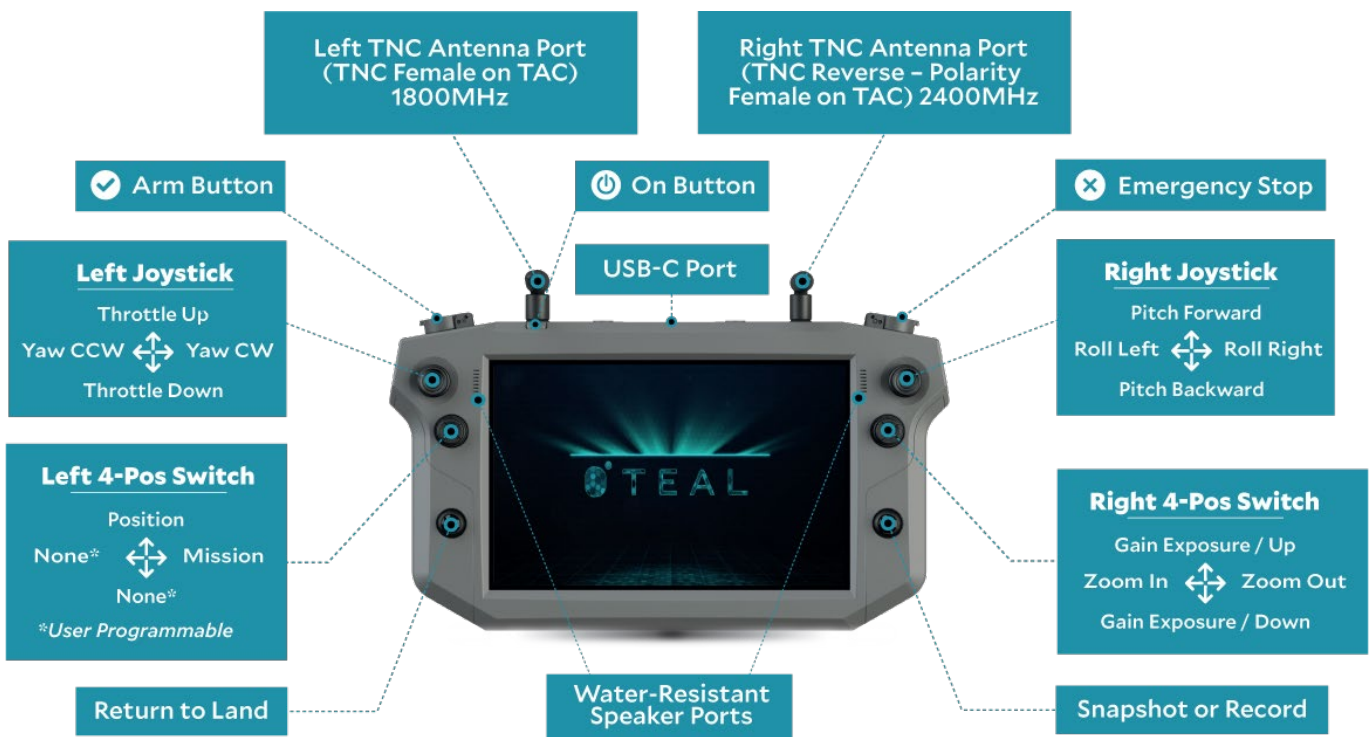

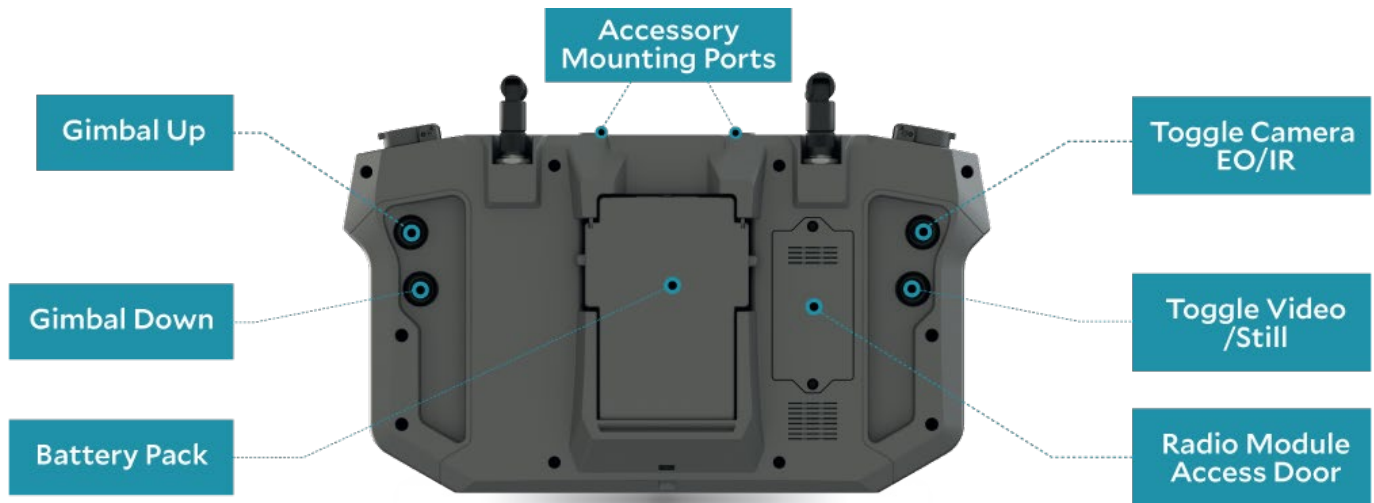

## 3. GETTING STARTED

Estimated time: 75-95 minutes.

### 3.1. ABOUT THE BATTERY PACKS

The air vehicle (AV) and the ground control station (GCS) each require a lithium-ion Teal battery pack. The battery does not have to be connected to a GCS or AV to power on. When the battery is not attached to an AV or GCS, the battery automatically shuts off after three seconds. When the battery is attached to an AV or GCS, the battery needs to be powered off manually.

### 3.2. ABOUT THE BATTERY CHARGER

The provided charger power supply operates on an AC voltage range of 100-240 VAC. The AC cord can be replaced with an appropriate cord. It is safe to remove the battery from the charger at any time.

### 3.3. BATTERY CARE

Use the charger to pre-heat battery packs if the battery is exposed to low temperatures (32 °F [0 °C] or lower) for more than one hour. The time it takes to pre-heat cold batteries varies according to the starting temperature of the battery pack.

#### WARNING



Store batteries between -20 °C to 45 °C (-4 °F to 113 °F).

Do not keep batteries in hot vehicles. Improperly stored battery pack may become unstable, overheat, damage battery cells, and potentially catch on fire.

### 3.4. BATTERY STATUS

The battery does not have to be connected to a TAC or AV to power on. When the battery is not attached to a Teal 2 or TAC, the battery automatically shuts off after three seconds. When the battery is attached to a Teal 2 or TAC, the battery needs to be powered off manually.

Press the battery's power button to power on a battery pack. The charge status is indicated by five LED lights. All five LED lights illuminate when the battery pack is completely charged.







User Action	LED Action	Mode	User Action	LED Action	Mode
Tap Power Button	 1 - 5 LEDs turn on, then off	Charge Level indication for 2 seconds	Release after 4-sec hold	 Middle LED stays on	Battery Power is <b>ON</b>
Tap Power Button	 2 <sup>nd</sup> & 4 <sup>th</sup> LEDs flash 3 times	In low-power <b>Shipping Mode!</b> Charge to exit!	Press & Hold for 4 seconds	 Sequential turn-off	Toggles battery Power to <b>OFF</b>
Press & Hold for 4 seconds	 Sequential turn-on	Toggles battery Power to <b>ON</b>	Release after 4-sec hold	 All LEDs off	Battery Power is <b>OFF</b>

Figure 1 Battery Status Lights

Batteries ship in a low-power status called shipping mode.

To see if the battery is in shipping mode:

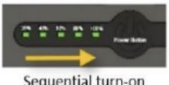
1. Press the battery power button.
2. Watch the LEDs. If the second and fourth LEDs flash three times, the battery is in shipping mode.
3. Charge the battery. Charging the battery takes the battery out of shipping mode.



### 3.5. CHARGE THE BATTERY PACKS

Charge each battery pack on the Teal battery charger before each flight. Use the provided charge adapter and power cord to charge the battery.



Battery packs fully charge in 65 minutes. Batteries charge from 10% to 80% in 35 minutes.

To charge the battery pack:

1. Insert the DC charger power cable into the charger.
2. Plug the AC power cord into an AC outlet. The green LED lights illuminate when it receives power.
3. Insert the battery pack onto the charger, fully engaging the side latches with the charger.

To remove the battery pack from the charger:

1. Pull back the two side latches.
2. Pull the battery pack vertically away from the charger.

All five LED lights illuminate when the battery pack is completely charged.

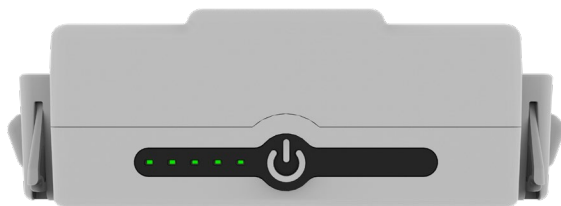

#### CAUTION



After charging, remove the battery from the charger to prevent prolonged heating and damage to the battery.



Charge within the temperature range of 0 °C to 45 °C (32 °F to 113 °F). Do not operate the charger in direct sunlight to avoid exceeding temperature limits.



Unplug the charger power supply when not in use to prevent unnecessary heating and wear on electrical components.



Always power down the Teal 2 and TAC before removing and replacing battery packs.

### 3.6. PREPARE THE VEHICLE FOR FLIGHT

To prepare the vehicle for flight:

1. Inspect arms for airworthiness. Check for damages such as cracks, separated seams, or fractured.
2. Attach the arms to the Teal 2.
  - a. Insert the clockwise (CW) and counterclockwise (CCW) arms into their corresponding sockets. CW arms do not fit into CCW arms. CCW arms do not fit into CW arms.

- b. Make sure all four arms lock into their fully extended position.



**WARNING**



Replace the arm if the arm lock mechanism is worn and does not lock.

3. Inspect the propellers for airworthiness. Check for damages such as warped, chipped, or cracked propellers.
4. Attach the propellers to the arms.
  - a. Match the clockwise (CW) black propeller rivets to the CW black ring on the propeller motor.
  - b. Match the counterclockwise (CCW) silver propeller rivets to the CCW silver ring on the propeller motor.
  - c. Align and insert the three legs on the underside of the propeller into the three slots on the motor.
  - d. Push down to compress the spring on the shaft.
  - e. Rotate a quarter turn until it hits its mechanical limit.
  - f. Allow the spring to push up the hub into its locked position.

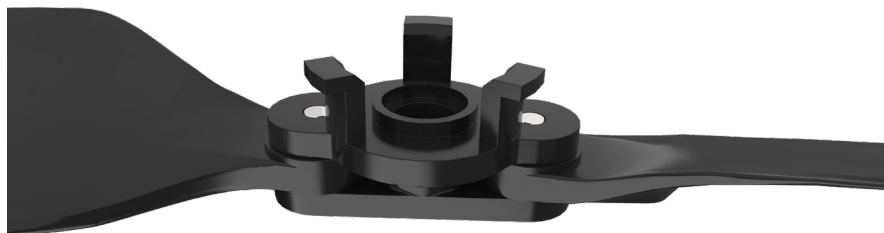

**WARNING**



Replace propellers if they are damaged or cracked.



**Note:** CW propellers lock into place by turning them in a CCW direction. CCW propellers lock into place by turning them in a CW direction.



Figure 2 Clockwise and counterclockwise arms and propellers.

5. **Remove** the gimbal protective cover.
6. **Insert** and latch a fully charged battery pack into the battery compartment on the bottom of the Teal 2.
7. **Verify** both battery pack latches are fully engaged with the airframe to secure the battery pack.

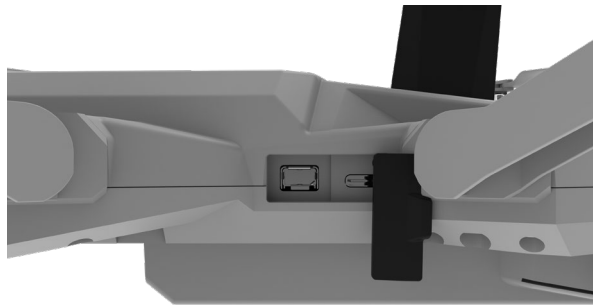

8. **Insert** the SD card into the card slot in the airframe with the gold pads up. This step is optional.

### 3.7. PREPARE THE TAC

To prepare the TAC for Teal 2 control:

1. Attach the antennas. Mate one antenna female to male and the other antenna male to female. Screw the antennas in a clockwise direction onto the TNC connectors on the GCS.

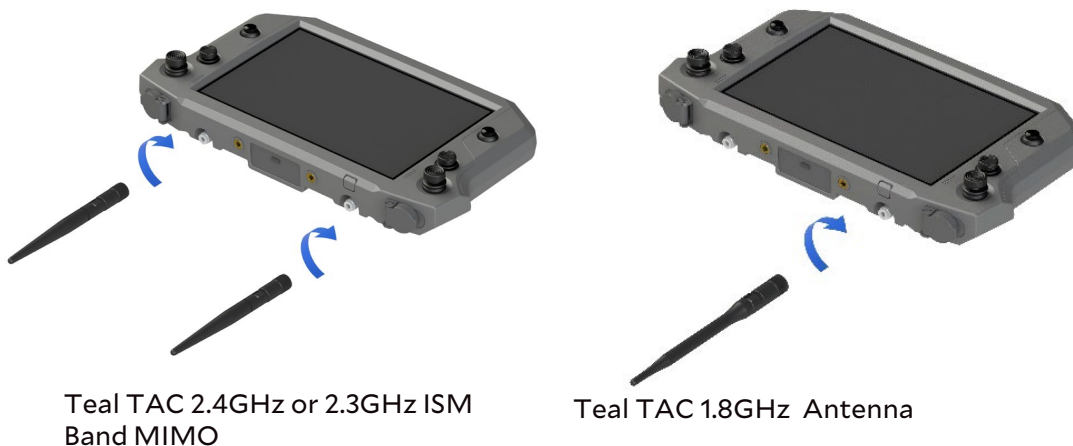

2. Insert a fully charged battery pack. Make sure the side latches are fully engaged with the TAC housing to secure the battery.



### 3.8. POWER ON THE TAC

To power on the TAC:

1. Insert a battery pack into the TAC battery housing.
2. Press and hold the battery pack power button for four seconds. The center LED lights glow when the battery power is on.
3. Press and hold the GCS screen power button for two seconds. The tablet displays a lock screen. The serial number for the tablet is at the bottom of the screen.
4. Swipe up to access the home screen. The home screen displays applications.

#### WARNING



When the battery is on, the radio transmitter card on the GCS is powered and active. Even when the screen is off, the transmitter is active. Power off the battery on the GCS to silence the radio.

### 3.9. POWER ON THE AV

To power the AV:

1. Insert a battery pack into the Teal 2 battery housing.
2. Press and hold the battery power button for four seconds. The center LED lights up when the battery pack is on.
3. Listen for the exhaust fan to start-up.
4. Wait for the side panel lights to illuminate. This takes approximately 15 seconds and indicates the Teal 2 is powered on.
5. Wait for the gimbal to center and level itself in a forward-facing position. Gimbal movement means gimbal startup was successful. The AV is ready to link with the GCS.

#### WARNING



If the AV exhaust fan does not start, power off the AV immediately.



### 3.10. THE TAC APPLICATIONS

The TAC houses a Samsung Galaxy tablet running the Android operating system.

The applications are available upon opening the home screen.

The available applications are:

- The Teal QGC application contains the settings and controls for customizing AV settings for flight.
- Teal settings application where you can pair the AV and GCS, view the operator's manual, transfer maps, and configure other settings.
- The Teal TAC settings application. Use this app to access other settings for the TAC.
- Teal updater application. Use this app to update the AV firmware.
- The My Files application. Use this app to access flight logs, maps, screenshots, and other files.
- The information icon. Use this icon to access settings.

### 3.11. CONNECT TO WIFI FOR CORRECT TIME

Correct time is critical for accurate Teal 2 RID information.

To receive the correct time and date, connect the TAC to WIFI. Connect the TAC to WIFI each time the TAC powers on for flight.

To connect to WIFI:

1. Power on the TAC.
2. When the lock screen appears, swipe up to open the tablet.
3. Tap **Teal Settings**.
4. Tap **Configure Device**.
5. Under **Network** tap Wi-Fi. Active Network now highlights Wi-Fi.
6. Tap the **TealQGC** app screen to maximize it.
7. Check the time and date are up to date.
8. Open **Teal Settings**.
9. Tap **Configure Device**.
10. Under Network tap **Drone**. Active Network now highlights Drone.

### 3.12. PAIR AND CONNECT THE TAC WITH THE TEAL 2

Most vehicle and TAC kits are paired in the factory. The system remembers the pairing and automatically connects when the Teal QGC app launches. See the pairing section in Teal 2 Teal 2 for how to pair a AV and TAC.

To verify the Teal 2 and TAC are paired and connected:

1. Power on the Teal 2
2. Power on the TAC.
3. From the home screen, tap the **Teal QGC** icon.
4. If the Teal 2 is listed in the upper left corner of the screen, the Teal 2 and TAC are connected.

If the vehicle and TAC are not paired, pair the Teal 2 and TAC.

To pair the Teal 2 and TAC:

1. Open the Teal Settings application.
2. Click **Pair Drone +**.
3. Press and hold the pair button on the back of the vehicle for five seconds.
4. Click **Continue**.
5. Select the vehicle to pair. Pair one vehicle at a time.

6. Click **Pair with this device**.
7. Confirm the settings.
  - a. Confirm the network name, password, channel, and drone range.
  - b. The available drone ranges are short, mid, and long. Long is the default drone range. Do not change the drone range unless a lower power range is needed.

Drone Range	Distance	Bandwidth	Power
Short	500m	8 MHz	7dbm
Mid	3000m	8 MHz	20dbm
Long	7500m	8 MHz	30dbm

8. Click **Confirm and start pairing**.
9. When pairing is successful, click **Finish**.
10. Click Teal QGC in the bottom right corner to return to the Fly View.



**Note:** To change the channel after the vehicle is paired, unpair the vehicle. Follow the pairing steps and change the channel on the confirm settings page

## 4. FLY VIEW OVERVIEW

Fly View is the main screen in the Teal QGC app. The Teal QGC fly view automatically launches when the TAC powers on. Use Fly View to command and monitor the vehicle during flight.

Use the fly view to:

- Pair the Teal 2 and TAC
- Run the automated pre-flight checklist, if enabled.
- Control missions.
- Arm or disarm the Teal 2
- To set the E-stop button.
- Takeoff.
- Land.
- Return to launch (RTL).
- Go to or orbit a specified location.
- Switch between the map view and video view
- Display mission, telemetry, and other information for the Teal 2.

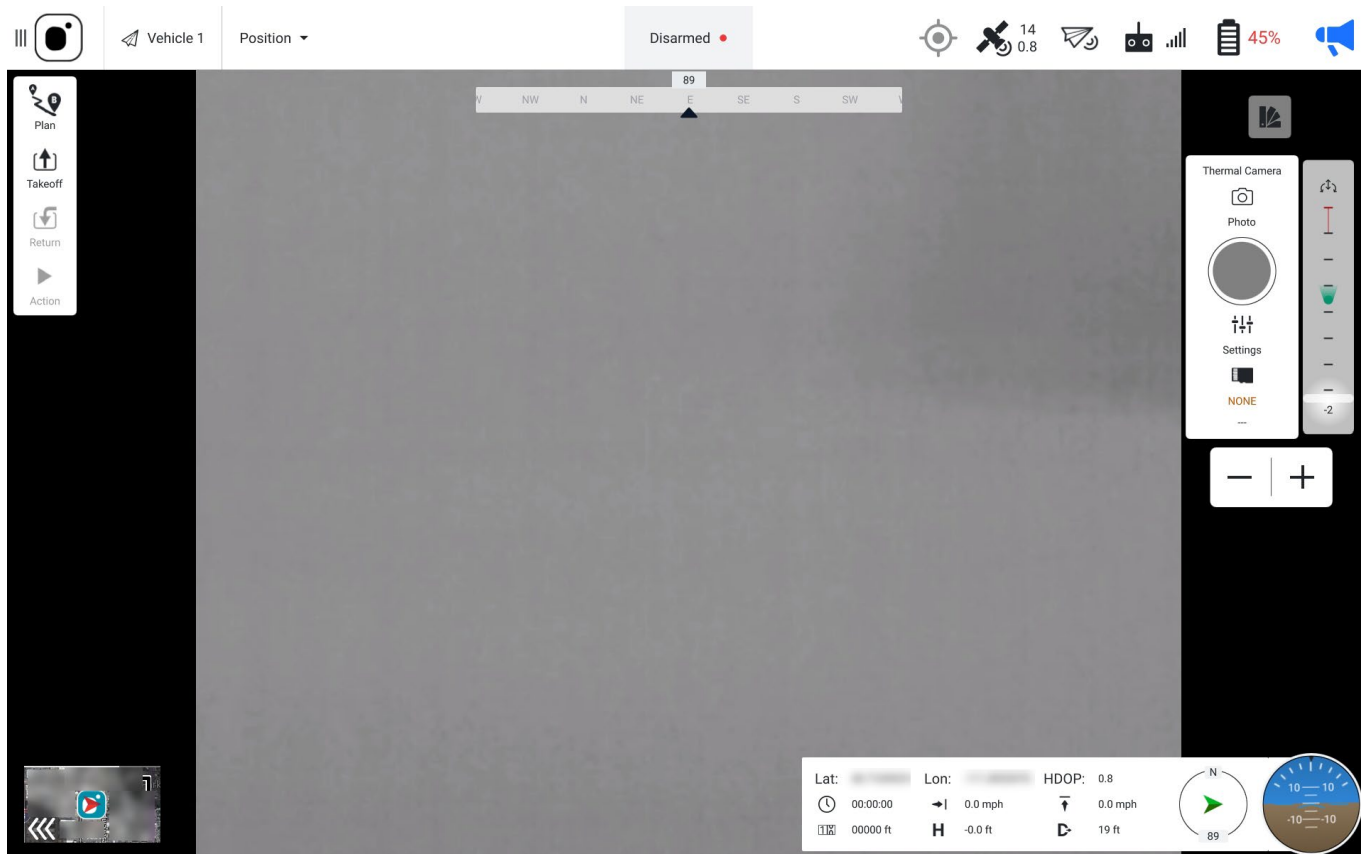

## 4.1. FLY VIEW MAP OVERVIEW

The fly view displays a map and video view in a large window and a small window. Tap the small screen in the left bottom corner to change which view displays on the large window.

The map shows the position of the TAC, the Teal 2, and the mission. Use a finger to reposition the map. If the Teal 2 moves outside the view of the screen, the map automatically re-centers over the Teal 2.

To zoom in on the map, touch the screen with two fingers and slide them apart. To zoom out on the map, touch the screen with two fingers and slide them together.

## 4.2. FLY VIEW MAIN TOOLBAR

The Main Toolbar spans the width of the screen at the top of the Fly View and displays system information.

Status icons display when Teal QGC connects to a vehicle. Click an icon for detailed information.

These icons are referenced throughout the manual.

These icons and indicators are:

### 4.2.1. VIEW-SELECT MENU



The **Main menu icon** in the left corner of the main toolbar contains a vertical view-select menu.

The menu options are:

**Fly:** Control and monitor the Teal 2 and view streaming video while in flight.

**Plan:** Create autonomous missions.

**Analyze:** Download logs and access the MAVLink console.

**Vehicle Setup:** Configure and tune the vehicle.

**Photos:** Manage downloaded photos, and view photo metadata.

**Settings:** Configure the Teal QGC app.

#### 4.2.2. PAIRED VEHICLE IDENTIFIER

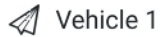

The Paired Vehicle icon displays the unique identifier (UID) of the paired, connected vehicle. If multiple vehicles are paired, only the connected vehicle is displayed.

#### 4.2.3. FLIGHT MODE INDICATOR



The flight mode indicator displays the set flight mode or the system. Touch this icon to display a drop-down menu to select either altitude mode or the position mode.

Alternatively, use the **left castle switch** to change the flight mode.

#### 4.2.4. ARMED AND DISARMED STATUS



The armed and disarmed status is centered on the main toolbar. This shows if the AV is currently armed or disarmed. **Touch** this icon to display a confirmation slider box to arm or disarm the AV.

Use this icon as an alternative to the GCS buttons.

#### 4.2.5. RID STATUS INDICATOR ICON



The RID Status Indicator icon shows the RID status of the AV. In the event of RID broadcasting failure, an emergency status appears on the TAC. If the AV detects an error during flight, RID alerts the pilot and returns the Teal 2 to the landing point.

#### 4.2.6. RID EMERGENCY DECLARATION ICON



Tap the RID Emergency Status Declaration icon to manually declare an emergency. If the pilot detects an issue with the Teal 2, they can manually input an emergency status.

#### 4.2.7. GPS STATUS ICON

Touch the GPS status icon to view details of GPS Count, GPS Lock, HDOP, the Vertical Dilution of Precision (VDOP), and Course Over Ground (COG).



The top number of the icon represents the number of satellites. The bottom number represents the current horizontal dilution of precision (HDOP) value. A good HDOP value is below one. An acceptable HDOP value is below two. Tap the icon to view the GPS status.

**GPS LOCK:** Indicates the current type or level of GPS lock. Verify the GPS lock is acquired. This ensures the correct flight mode. A three-tone chime from the AV indicates GPS lock.

**COG:** Indicates the compass direction the AV is traveling. Note that this may or may not be the same as the heading, which is the compass direction the AV is pointed. Wind may cause the COG to differ from the AV's actual heading.

### CAUTION!



It is critical for AV to be connected to at least eight satellites to triangulate the position of the vehicle. Ten satellites is recommended.

#### 4.2.8. RADIO CONTROL (RC) RECEIVED SIGNAL STRENGTH INDICATOR (RSSI) ICON



The RC RSSI indicates the radio signal strength as is common on consumer cell phones. Touch this icon to view the RSSI values between the GCS and the AV. The RSSI value represents the signal strength. Reference the table below for RSSI values.

RSSI Value (dBm)	Signal Strength	Notes
Higher than -30	Overpowering	Dropping connection Dropping data Severe Latency Oversaturation of the receivers
-30 to -44	Excellent	
-44 to -55	Good	
-55 to -65	Okay	
-65 to -70	Weak	Starting to see Latency
-70 to -75	Extremely Poor	Latent Dropped data
-75 to -85	Severe Risk of Loss	You are on the edge and will start to lose connection
Less than -85	Connection Loss	Expect zero working functionality

#### 4.2.9. BATTERY ICON



This icon shows the battery charge level of the AV. Check the GCS's battery charge level by tapping the battery power button on the back of the GCS.

The bottom number represents the time remaining before RTL activates.

Touch this icon to view the AV battery's current voltage level and the accumulated amount of power consumed by the AV (in mAh) in this session.

### CAUTION!



The AV will not arm when the battery pack charge level is below the battery warn level. Check the safety setup under Main Menu Icon>Vehicle Setup>Safety

#### 4.2.10. AIR VEHICLE MESSAGES ICONS



The AV Messages icon alerts the pilot to messages from the AV. Messages include warnings, errors, and other information. The icon is grayed-out until there is an AV message. When there is an AV message, the icon turns blue. If the message is critical, it shows a warning icon. Touch the icon to view the messages.

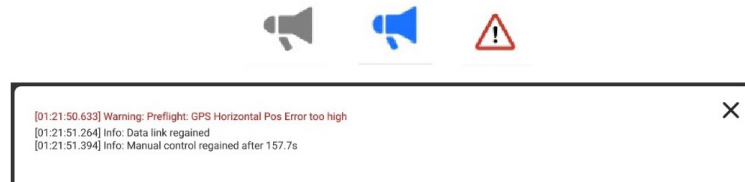

Figure 3 AV Messages icon alerts

Closing the pilot message window turns the warning icon back into the gray megaphone icon.

Old messages can be reviewed by touching the gray icon. All messages remain accessible until the user permanently deletes them. Touch the trash can symbol in the lower right-hand corner of the message window to delete the AV messages.

**CAUTION!**



Touching the trash icon permanently deletes all messages. Messages cannot be individually deleted.

### 4.3. FLY TOOLS OVERVIEW

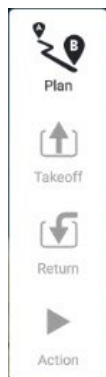

The fly tools box is fixed vertically near the upper left-hand corner of the Fly view.

These functions found in the Fly Tools are the Pre-flight checklist, Takeoff, Land, and Return/Return to Launch (RTL).

The Pause function causes the Teal 2 to hover and can be used in most operations, to include takeoff, land, orbiting, etc.

The Action button offers additional options, to include changing the altitude, and starting and resuming a mission.

Find more information in the Pre-flight, In-flight, landing, and TAC details section.

### 4.4. CUSTOMIZING PERSONAL SETTINGS

Use the **General Settings** screen to customize user preferences. The most commonly used ones are referenced here. For a more complete list, please see the Teal QGC App section.

1. Touch the **Main menu** icon in the top left of the screen.
2. Select **General**.

A list of settings appears.

**UNITS:** Allows selection between feet and meters, imperial and metric, and Celsius and Fahrenheit.

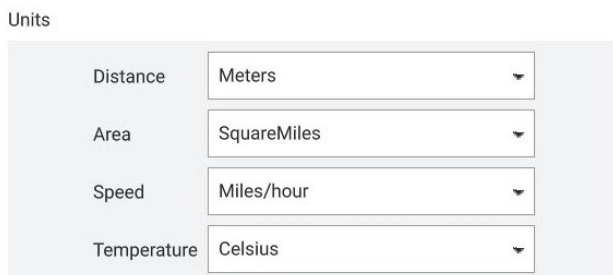

**MISCELLANEOUS:** Select your language, dark/light mode, map provider and map type, etc.



**Note:** As of the publication of this manual, a software bug has made selecting a different language not an option at this time and is being investigated.

**DATA PERSISTENCE:** Disabling this option will result in telemetry logging and map tile caching to not be written to disk. This can be useful for security reasons but can also result in unintentional data loss.

**TELEMETRY LOGS FROM VEHICLE:** Saves telemetry logs in different formats to the vehicle which can later be downloaded to the TAC, to include logs in a CSV format for importing data into other programs for data analysis, such as spreadsheets.

**FLY VIEW:** These user preferences include using the pre-flight checklist, centering the map on vehicle,

Miscellaneous

Language: System

Color Scheme: Outdoor

Map Provider: Bing

Map Type: Hybrid

UI Scaling: - 79% +

- Use Vehicle Pairing
- Display MGRS coordinates
- Mute all audio output
- AutoLoad Missions
- Clear all settings on next start
- Use Embedded Virtual Keyboard (requires restart)
- Announce battery lower than 20 %

setting gimbal joystick and slider speeds.

**PLAN VIEW:** Entering the DEFAULT MISSION ALTITUDE value here sets the altitude in the Plan screen at which missions fly by default, unless otherwise specified.

**VIDEO & VIDEO RECORDING:** These preferences are still under development.

**PICTURE SETTINGS:** Configures full-resolution images whenever a snapshot is taken. **Check** the DOWNLOAD FULL RES IMAGE IN FLIGHT box.

**CAUTION!**



Enable all photo functions before flight or else they will not be stored locally on the TAC and will not be transferrable after the mission.

**TEAL QGC SOFTWARE VERSION:** The current version of the Teal QGC software version that has been downloaded onto the TAC is shown here. See the **Teal Updater App** section for instructions to update the software/firmware.

## 4.5. DOWNLOADING MAPS

Upload maps, create missions, define safety parameters, set units of measurement and other user setting preferences.

Maps need to be downloaded for each area only once. We recommend downloading maps before going into the field. This can be done while in the field as long as there is a wi-fi connection.



Follow along with our instructional video, *Downloading Offline Maps Teal 2 Drone* on our website at: <https://tealdrones.com/support/training-videos/>



**Note:** “Offline maps” is the name given to the maps on the TAC. There are no “online” maps. Different map areas are called “Tile Sets”.

Connect the TAC to an external storage device via the USB-C port.

1. Open **Teal Settings**.
2. Click **Transfer maps**.
3. Tap **Continue**.
4. Allow access to the storage device.
5. Select the map tile sets for transfer.

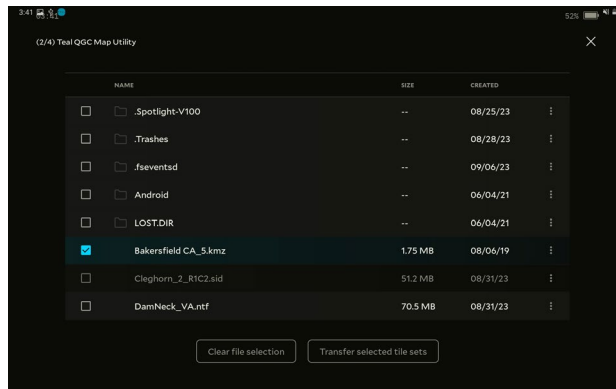

6. From the content list, select the files for transfer.
7. Tap **Transfer selected tile sets**.
8. Once the tiles transfer, click **Go Back** or **Open TealQGC**.



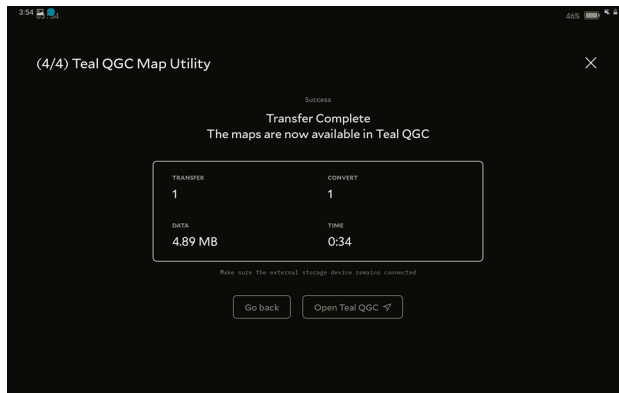

File sets are downloaded for planning and running missions in specific geographic areas. Depending on the mission type and location, cyber security best practice dictates that these prior tile sets should be deleted from the TAC.

## 4.6. MISSION PLANNING

This screen is used to plan autonomous missions and save or upload them to the Teal 2 during mission planning or while in the field. Here you can set takeoff and return to launch commands, waypoints, rally points, geofences, and survey patterns.

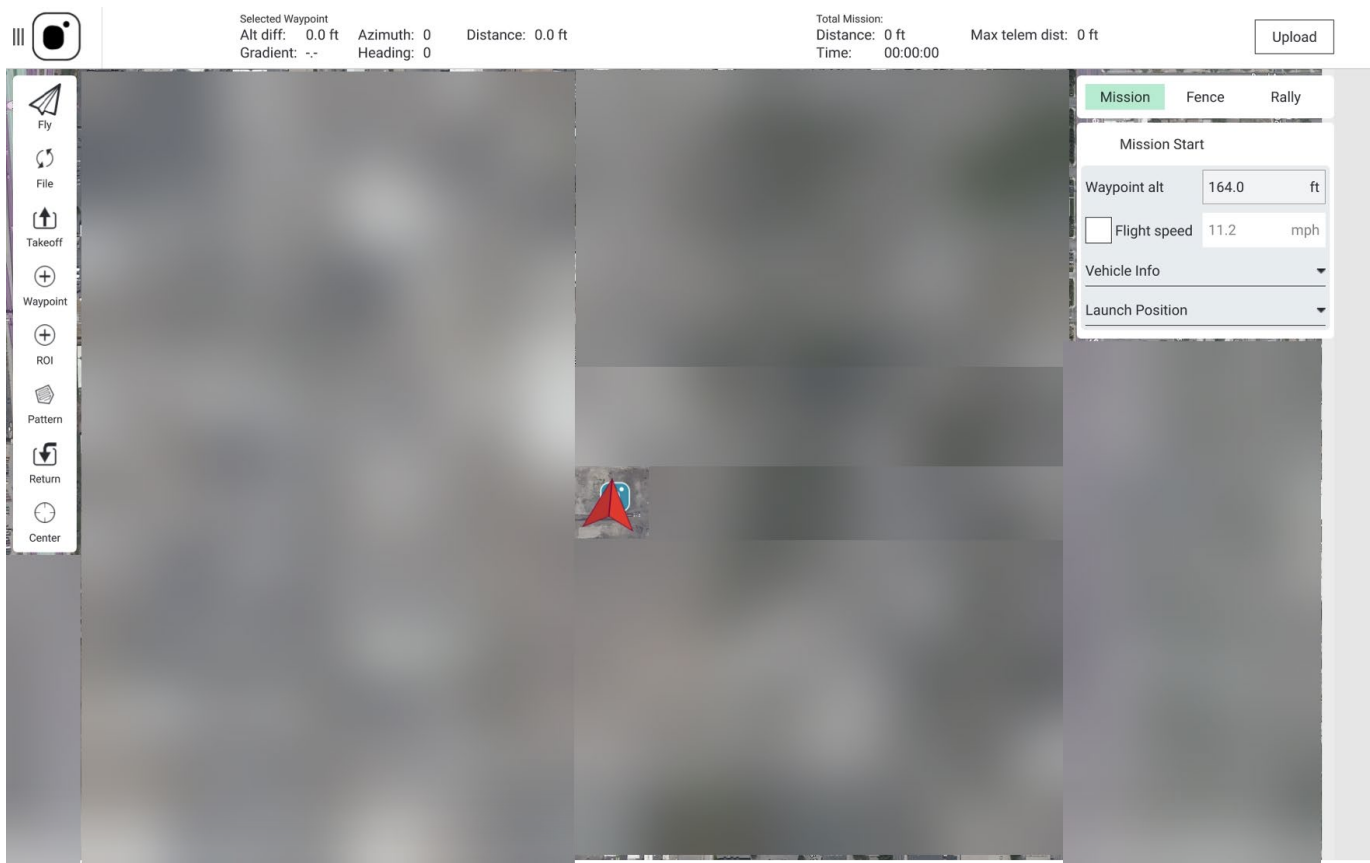

**WAYPOINT:** Program a location in 3D space to which a vehicle is programmed to fly during a mission. When a mission is defined in the **Plan Screen**, these waypoints can be individually defined and edited, and parameters associated with them can be viewed.

**RALLY POINT:** Pre-program a secondary landing position, or a loiter/holding position. This can be added as a part of a survey mission or used when manually flying.



**Note:** When programming a rally point, be aware that the Teal 2 will either fly to the rally point or RTL point, whichever is closer to the Teal 2 when the RTL is initiated.

**GEOFENCE:** Create an optional inclusive or exclusive perimeter that can be embedded within a mission that will automatically cause the Teal 2 to RTL if breached.



**Note:** Additional geofences can be separately configured as safety parameters and are created in the **Safety Settings** under **Vehicle Setup**.

Once a mission is planned and uploaded to the Teal 2, use the FLY VIEW and Mission Flight Mode to fly the mission.

Follow along with our instructional video, *Planning a Time-Based Mission: Teal 2 Drone* on our website at: <https://tealdrone.com/support/training-videos/>



#### 4.6.1. PROGRAMMING A SURVEY MISSION

1. Touch the **Main menu** icon in the Fly View toolbar.
2. Select **Plan**.
3. A Mission Plan window will appear.



4. Set the map to the desired mission area.
5. Configure the altitude and flight speed. 30 m AGL and 3 m/s is a good baseline.
6. Select **Takeoff** in the menu to the left.
7. Add the take off point by touching the estimated location on the map.



**Note:** Once GPS is acquired in the field, the takeoff point will shift to where the Teal 2 is physically located. This can be mitigated by either having a set takeoff point, or by adjusting the takeoff point before flight.

8. Select **Waypoint**.

9. Add a waypoint by touching the desired location on the map.
10. Configure the gimbal position.
11. Select **Pattern** then **Survey** to create a survey area and pattern.

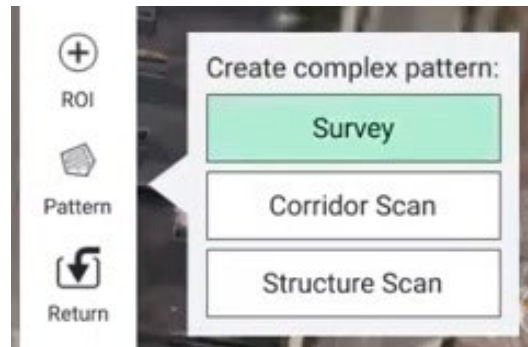

12. Adjust the survey size and location to your needs.
13. Select **Done with Polygon** when finished.
14. Select the camera that you would like to use from the drop-down menu.
15. Adjust the percentage of overlap or ground resolution, if needed.

**CAUTION!**



Make sure to verify the altitude when adjusting the ground resolution settings.

16. Go to the **Grid** window to adjust the angle of the survey to minimize turns, altitudes, and entry points to adjust the length of the flight.
17. Select **Waypoint**.
18. Add one additional waypoint toward the exit point of the survey pattern.
19. Set the gimbal to 0°.
20. Select **Return**.
21. This will create the RTL point. This can be any location but is usually the same as the take-off point.
22. Select either **Upload Required** to load the mission onto the Teal 2 or select **File** to save the mission and upload at a later time.

#### 4.6.2. PROGRAMMING A GEOFENCE

Use this option to setup a Geofence within a mission. Note that a Geofence can also be programmed separately from a mission in the **Safety Settings** page by following the instructions in the following **Vehicle Setup** section.

1. Select **Fence** in the **Mission Plan** window.
2. Select the desired geofence perimeter shape and then select the area on the map, or select the free-form option and create the desired perimeter on the map.
3. Select **Done**.
4. Select either **Upload Required** to load the mission onto the Teal 2 or select **File** to save the mission and upload at a later time.



**Note:** Only one mission can be on the Teal 2 at a time. If you upload a new mission, it will overwrite the current mission.

### 4.6.3. PROGRAMMING A RALLY POINT

1. Touch the **Main menu** icon.
2. Select **Plan**.
3. A **Mission Plan** window will appear.
4. Select **Rally**.
5. Add the rally point by touching the location on the map or by entering the exact coordinates in the field provided.
6. Select either **Upload Required** to load the mission onto the Teal 2 or select **File** to save the mission and upload at a later time.



**Note:** The vehicle will go to the RTL or rally point, whichever is closest to the Teal 2.

## 4.7. VEHICLE SETUP

Use this screen to customize safety parameters, calibrate the Teal 2, and to customize the joystick and buttons configurations on the TAC.

### 4.7.1. BUTTON & JOYSTICK SETUP

1. Connect the vehicle and the TAC.
2. Touch the **Main menu** icon.
3. Select **Vehicle Setup**.
4. Select **Joystick**.
5. Use the **General**, **Button Assignment**, and **Advanced** windows to customize the joystick and buttons, if so desired.
6. Select the **Set Teal Defaults** in the **Advanced** screen to reset all settings, if needed.

Low Battery Failsafe Trigger

Failsafe Action:	Return at critical level, land at emergency level
Battery Warn Level:	20.00 %
Battery Failsafe Level:	10.00 %
Battery Emergency Level:	5.00 %

General	Button Assignment	Calibration	
0 Step Zoom In	<input checked="" type="checkbox"/> Repeat	1 Step Zoom Out	<input checked="" type="checkbox"/> Repeat
2 No Action	<input type="checkbox"/> Repeat	3 No Action	<input type="checkbox"/> Repeat
4 Emergency stop	<input type="checkbox"/> Repeat	5 Continuous Gimbal Up	<input type="checkbox"/> Repeat
6 Continuous Gimbal Down	<input type="checkbox"/> Repeat	7 Trigger Camera / Video	<input type="checkbox"/> Repeat
8 Mission	<input type="checkbox"/> Repeat	9 No Action	<input type="checkbox"/> Repeat
10 No Action	<input type="checkbox"/> Repeat	11 Position	<input type="checkbox"/> Repeat
12 Arm	<input type="checkbox"/> Repeat	13 Next Camera	<input type="checkbox"/> Repeat
14 Toggle Camera Mode	<input type="checkbox"/> Repeat	15 Return	<input type="checkbox"/> Repeat

### 4.7.2. SAFETY SETTINGS SETUP

1. Connect the vehicle and the TAC.
2. Touch the **Main menu** icon.
3. Select **Vehicle Setup**.
4. Select **Safety**.

Here you can set a low battery failsafe trigger for when the battery pack reaches a certain percentage of charge. This includes setting the preferred failsafe action, i.e., return to launch, the battery warn level, the battery failsafe level, and the battery emergency level.

Recommendations:

- Low battery warning - set to at least 20%
- Critical battery level action - set to RTL at 10% or higher
- Emergency battery level action - set to land immediately at 5% or higher
- RTL height - set higher than any nearby obstacles to ensure the Teal 2 can clear them as it returns home

You can also establish an RC loss failsafe trigger and a data link loss failsafe trigger.

Loss of link results in an SOS tone from the vehicle. The SOS tone is three short tones, then three long tones, and then three short tones.

You can also establish a geofence that will confine the Teal 2 to the established parameters. This is helpful for those just starting out or for those who have definite boundaries that cannot be breached.

#### RC Loss Failsafe Trigger



RC Loss Failsafe Trigger settings:

- Failsafe Action: Land mode
- RC Loss Timeout: 3.0 s

#### Data Link Loss Failsafe Trigger

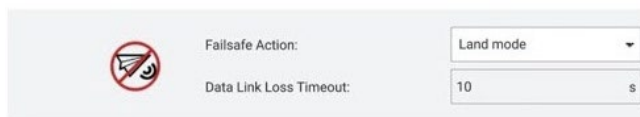

Data Link Loss Failsafe Trigger settings:

- Failsafe Action: Land mode
- Data Link Loss Timeout: 10 s

#### Geofence Failsafe Trigger



Geofence Failsafe Trigger settings:

- Action on breach: Hold mode
- Max Radius: 150 ft
- Max Altitude: 80 ft

You can also establish the Return to Launch (RTL) settings, the landing settings, such as landing descent rate, and enable/disable the vehicle telemetry logging.

#### Return To Launch Settings

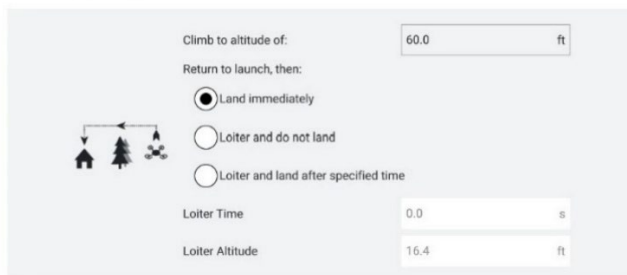

Return To Launch Settings:

- Climb to altitude of: 60.0 ft
- Return to launch, then:
  - Land immediately
  - Loiter and do not land
  - Loiter and land after specified time
- Loiter Time: 0.0 s
- Loiter Altitude: 16.4 ft

#### Land Mode Settings



Land Mode Settings:

- Landing Descent Rate: 1.3 mph
- Disarm After: 0.20 s

#### Vehicle Telemetry Logging

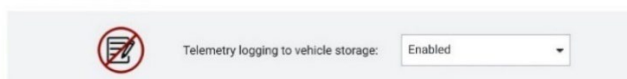

Vehicle Telemetry Logging settings:

- Telemetry logging to vehicle storage: Enabled

Other functions in the **Vehicle Setup** screen include sensor calibration. See instructions as to how in the **Teal 2 Details** section of this manual.

### 4.7.3. ENABLE PHOTO SETTINGS INSTRUCTIONS

All photo functions must be enabled before flight or else the media will not be stored locally on the TAC and will not be transferrable after the mission.

However, the tradeoff to having the media stored locally on the TAC during flight is a reduction of bandwidth which could degrade the quality of the media seen on the TAC fly view during the mission.

If possible, we recommend storing media on the SD card, but realize some security protocols will not allow this.

1. Touch the **Main menu** icon.
2. Select **Settings** at the bottom of the screen.
3. Select **General**.

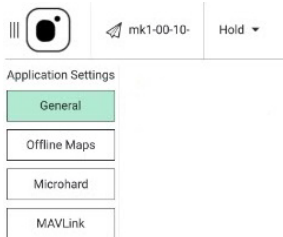

4. Scroll down to **Picture Settings**.
5. Check the **Download Full Res Image In Flight** box.

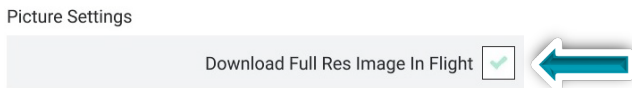

## 5. FLIGHT MODES

The Teal 2 has five different flight modes. The default flight modes are Position Mode or Manual Mode.

The TAC audibly announces the current flight mode and shows the current flight mode at the top of the screen.

### CAUTION!



Ensure that you are in the desired flight mode before arming the Teal 2.



**Note:** A three toned chime indicates the GPS lock is active. The top of the TAC screen on the satellite icon shows the GPS lock is active.

Additional flight modes can be programmed but are recommended for experienced Teal 2 pilots.

### 5.1. POSITION MODE

Position mode is an easy-to-fly mode and is the safest manual mode for new pilots. Position mode controls the attitude, altitude, heading, and horizontal position of the Teal 2.

If the Teal 2 acquires GPS before it is paired with the TAC, the system will automatically be set to Position Mode.

Position mode requires GPS. All the joysticks, switches, and buttons are the default functions are detailed in the TAC controls overview.

## 5.2. MANUAL MODE

Manual Mode is the most difficult flight mode to operate in. Only the attitude and heading are stabilized. Manual Mode is not pre-assigned by default to any control on the TAC.

If the Teal 2 is paired with the TAC before it acquires the GPS, the system will automatically be set to Manual Mode, but can then be set to Position Mode by moving the left castle switch up. The system can be set to Position Mode both before and during flight.

The roll and pitch joystick controls speed over ground in the left-right and forward-back directions.

The throttle and yaw joystick controls speed of ascent-descent and the rate of rotation on the horizontal plane.

When the joysticks are released and centered, the Teal 2 will NOT stop rotating around the axis, nor be stabilized in any way.

## 5.3. ALTITUDE MODE

Altitude mode is the safest **non-GPS** manual mode for new pilots. The Teal 2 defaults to Altitude Mode if it loses GPS signal during flight.

Altitude mode controls the attitude, altitude, and heading. The pilot must control the horizontal position and the Teal 2 is prone drifting with the wind if uncorrected.

The roll and pitch joystick controls speed over ground in the left-right and forward-back directions.

The throttle and yaw joystick controls speed of ascent-descent and the rate of rotation on the horizontal plane.

When the joysticks are released and centered, the Teal 2 will level and be locked into the current altitude and will continue to move along with any wind currents.

RTL is not available in this flight mode.

## 5.4. MISSION MODE

Mission Mode will execute a predefined autonomous flight plan that is created on or uploaded to the TAC. The flight plans may be uploaded before or during flight. Mission Mode requires GPS. No user intervention is required in Mission Mode.

### CAUTION!



Any TAC stick movement will change the Teal 2 from Mission Mode to Position Mode.

### WARNING!



The Teal 2 is not intended to perform acrobatic maneuvers, such as flips, rolls, and loops. Intentional aerobatics may result in an unrecoverable loss of control of flight, and all warranties are void if attempted.

## 5.5. ARM & EMERGENCY DISARM

The front panel includes a left and right-hand push button. A flip-guard door protects each button to prevent accidental actuation.

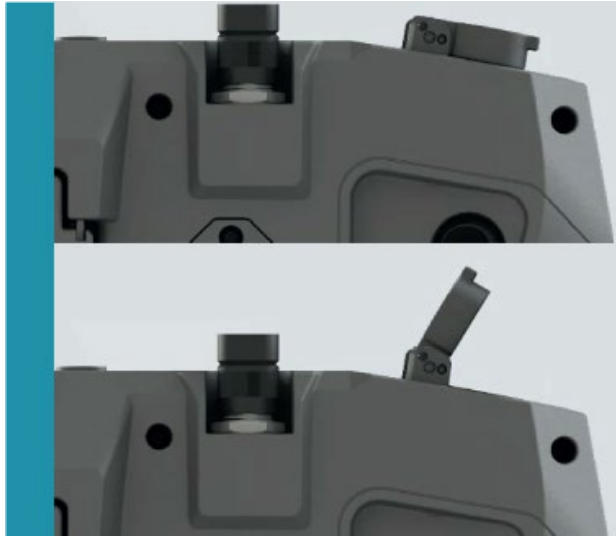

The default function for the left front button starts the motors, arming the Teal 2. This is the recommended setting for this button.

The right front button is the Emergency Stop (E-stop) button. Press this button to turn off the motors and disarm the Teal 2. This is the default and recommended setting for this button.

Access the arm and disarm functions in a confirmation window on the TAC.

### **WARNING!**



Disarming the Teal 2 while in flight causes it to free-fall. This may cause property damage, air vehicle damage, or serious injury or death.

## 5.6. DEFAULT CONTROLS

Please refer to the Tac controls overview on page seven for joystick and button locations.

The roll and pitch joystick controls speed over ground in the left-right and forward-back directions.

The throttle and yaw joystick controls speed of ascent-descent and the rate of rotation on the horizontal plane.

When the joysticks are released and centered, the Teal 2 will actively brake, level, and be locked to a position in 3D space, compensating for wind and other forces.

Instructions on how to program the joysticks, switches, and button functions are found in [SETTINGS](#) section of this manual.

### **THROTTLE UP / ASCEND**

To ascend the Teal 2, push the left joystick forward. The farther the joystick is pushed from its centered position, the faster the Teal 2 ascends on the vertical axis.

### **THROTTLE DOWN / DESCEND**

To descend the Teal 2, push the left joystick backward.



### YAW LEFT / Counterclockwise

To rotate the Teal 2 counterclockwise (CCW), move the left joystick to the left.

### YAW RIGHT / Clockwise

To rotate the Teal 2 clockwise (CW), move the left joystick to the right.

### PITCH FORWARD

To move the Teal 2 forward, move the right joystick up.

### PITCH BACK

To move the Teal 2 in reverse, move the right joystick down.

### ROLL LEFT

To roll the vehicle to the left, move the right joystick left.

### ROLL RIGHT

To roll the vehicle to the right, move the right joystick right.

## 5.7. STEALTH MODE

Stealth Mode disables external lighting and audible sounds from the vehicle. Boot up sounds, loss of link, and disarming event sounds are all disabled. The ground sensor is disabled during Stealth Mode and the vehicle will behave differently during takeoff and landing. Be careful when launching and landing the aircraft.



**Note:** Even in Stealth Mode, the vehicle lighting still briefly illuminates during boot-up. Use the Multifunction button on the back of the vehicle to change the lighting setting from white, IR, and off.

Stealth mode is persistent through battery changes and power cycles.

To enable Stealth Mode:

1. Open the Teal Settings application.
2. Tap the vehicle for Stealth Mode.

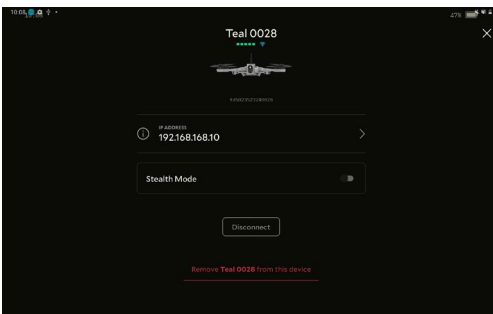

3. Tap the toggle next to **Stealth Mode**.
4. An information box appears reviewing the effects of Stealth Mode.  
**Note:** Stealth mode disables the downward facing infrared laser to reduce the IR signature of the aircraft. This may cause hard landings. Operators must carefully land the vehicle during stealth mode.

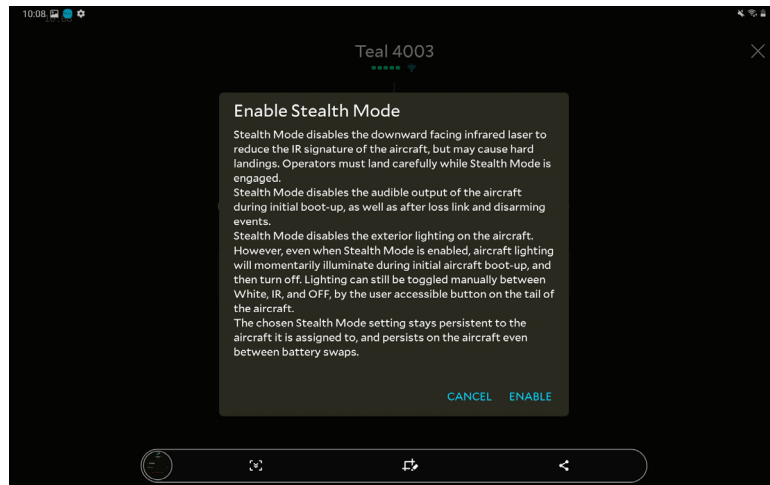

5. Tap **Enable**.

## 5.8. PRE-FLIGHT FLIGHT SAFETY

### 5.8.1. FLIGHT RESTRICTIONS & REGULATIONS

Complying with all FAA, federal, and local regulations ensures a safe and enjoyable experience for everyone. The FAA has great resources on their website to help you determine which rules and regulations apply to you depending on your experience level, certifications and licenses, or use of the Teal 2 at: <https://www.faa.gov/uas/>.

**NEVER** fly the Teal 2 over people and/or moving vehicles.

**NEVER** fly the Teal 2 beyond the visual line of sight of the Remote Pilot in Command (RPIC).

**NEVER** fly higher than the authorized 400 feet AGL restriction.

**NEVER** attempt to operate the Teal 2 without Remote Identification operable.

**ALWAYS** be aware of controlled airspaces and current flight restrictions.

### 5.8.2. BEST PRACTICES

**ALWAYS** exercise sound judgement and operate with due regard. As the Pilot in Command, you are solely responsible for the safe operation of your Teal 2.

**ALWAYS** err on the side of safety. If you hear or see anything that does not seem right or looks dangerous, land immediately and log the situation!

**ALWAYS** thoroughly inspect your Teal 2 before each flight in accordance with the preflight checklist, especially for damage before each takeoff and after each landing.

**ALWAYS** follow maintenance schedules and storage requirements as outlined in the user manual, especially for battery packs and propulsion assemblies.

**NEVER** alter the Teal 2 or TAC in any way that would cause damage, loss of control. Doing so would void all warranties.

Selecting the right location for your flight is critical. Find a space that is clear of tall trees, hills, or buildings that may impair the GPS reception and possibly control of the Teal 2.

**NEVER** fly over an area that will pose a hazard for people or property beneath it. Damaging property or injuring people with your UAV can have significant legal and financial consequences.

### 5.8.3. IN-FLIGHT EMERGENCY PROCEDURES

**ALWAYS** ensure a controlled takeoff, flight, and landing by familiarizing yourself with system controls and the user manual.

However, in the event of complete loss of control over the Teal 2/emergency situation, use the E-Stop button to shut off propulsion and immediately drop the Teal 2 from the sky. Be aware that this may result in:

- Partial or complete loss of the airframe, camera, gimbal, arms, motors, payloads and/or props.
- Partial or complete loss of data.
- Damage to property on the ground from vehicle impact.
- Significant injury or death of person(s) or damage to property struck by the falling Teal 2.

## 5.9. SYSTEM CAPABILITIES / OPERATING LIMITATIONS

TEAL 2	
Flight Time	Up to 25 minutes (22 minutes at hover to 0% full battery discharge) at 4,327 feet (1,319 m) above sea level.
Top Horizontal Speed	32.8 ft/s (10 m/s)
Maximum Vertical Speed	8.2 ft/s (2.5 m/s)
Maximum Servicing Ceiling	10,000 ft (3,048 m) MSL
Signal Range	1.8 GHz line of sight: up to 2.17 miles (3.5 km)* 2.3 GHz MIMO line of sight: up to 1.86 miles (3 km)* 2.4 GHz MIMO line of sight: up to 1.86 miles (3 km)*
Maximum Auxiliary Payload Weight	75 grams
Operating Frequencies	1.8 GHz 2.3 GHz 2.4 GHz
Encryption	AES 256
Protocol	MAVLink
EO Recording	4,000 x 3,000 @ 15 FPS
Video Format	H.264 Transport Stream and MP4
Gimbal Range	Pitch: -120° to +120° Roll: -35° to +35°
IR Sensor	FLIR Boson, 640 x 512 Pixels
IR Video Recording	640 x 512 @ 30 FPS
Remote Identification	Bluetooth 4 and 5**

*\*Range estimates represent maximum command and control (C2) link performance in optimum environmental conditions. To ensure safety of operations, the Teal 2 must be operated within the RPIC's line of sight at all times.*

*\*\* Remote ID is reliant on georeferenced position from the GPS receivers onboard the aircraft and TAC. Loss of GPS reception, or GPS dilution may affect the performance of the Remote ID system, and subsequently the adherence of the aircraft to 14 CFR §89.310(h). Teal 2 pilots must adhere to the limitations and procedures described on [page 48](#) of this document to avoid interruption of operation and potential RID failure.*

### TAC SYSTEM (Teal 2, TAC, BATTERY PACKS)

Operating Temperature Range -32 °F to 110 °F (-35.6 °C to 43.3 °C)



Note: In low temperatures (32 °F (0 °C) or below), pre-heating of the battery pack is required by placing it on the charger before flight.

Operating Humidity Range	10% to 90% RH, non-condensing
<b>TAC SYSTEM</b>	
Operating Frequencies	1.8 GHz 2.3 GHz 2.4 GHz
Tablet Display Resolution	WUXGA (1920 x 1200)
Tablet Display Brightness	550 nits (outdoor conditions only)
Tablet Interaction	Glove Mode
Wi-Fi	802.11 a/b/g/n/ac 2.4 or 2.3 G+5 GHz, VHT80
GPS	GLONASS
Security	Knox, Fingerprint Reader, and PIN

## 5.10. PRE-FLIGHT CHECKLIST

An automated pre-flight checklist in FLY TOOLS can be used to run through standard checks to ensure that the vehicle is configured correctly and is safe to fly. Enable the tool by navigating to APPLICATION SETTINGS > GENERAL > FLY VIEW and select the USE PREFLIGHT CHECKLIST checkbox. The tool will then be added to the Flight Tools box. Touch the checklist icon from the Fly view to open the checklist.

### 5.10.1. OPERATIONS CHECKLIST

Check air space for restrictions and obtain authorization as required by the appropriate authorities having jurisdiction and follow all FAA, federal, and local rules and regulations. Verify the airframe and each payload, propulsion, and battery system is air-worthy and not damaged.

<b>1-PRE-MISSON</b>	
Air Space Restrictions	Checked, in compliance
Applicable Authorizations	Obtained
Weather	No limitations exceeded
Maps	Uploaded to TAC
Battery Packs	Charged
Mission Plans	Uploaded to TAC
Field Repair Kit	As required
T2/TAC Initial Pairing	Complete
TAC User Preferences	Set
<b>2-PRE-FLIGHT</b>	
Wind	Up to 18 mph/ 25 mph gusts
Temperature Range	0 °F to 110 °F (-17 °C to 43 °C)
Direct Sunlight	Limit until use
Launch Point	Clear of debris, 10 ft radius, unobstructed

### **3-PHYSICAL INSPECTION**

Arms	Intact at seam, secured into place
Propellers	No bending, warping, chips, or cracks found Clear of interference from accessories.
Fasteners	No screws missing from airframe
Camera	Clear of debris, unblocked
Motors	Spin freely, no significant resistance, all springs present
Gimbal Protective Cover	Removed
Battery Packs	Fully charged
Antenna	Clear of interference from accessories
SD Card	Inserted (optional)
<b>4-SYSTEM POWER / PAIRING</b>	
Teal 2	Powered on
TAC	Powered on
Teal QGC App	Loaded, main screen displayed in TAC
Remote ID	Verify Remote ID System Operationa
GE/TAC Comms Link	Established
*GPS	Acquired (8 minimum, 10 recommended)
Calibration	If needed, complete
*Channel/Frequency	Deconflicted

\* Denotes Impact of Safety of Flight

Always perform a functions check before the first flight or mission of the day. It can be performed

## 5-SYSTEM CHECKS

Button Assignments	Assigned (if not using default settings), calibrated, verified
*Safety Parameters	Set to user's site, mission, and environment
*RTL Height	Verified
*Compass	Stable, accurate
*Attitude	Verified
Gimbal	Functional
EO Camera Video Stream	Displays in TAC
IR Camera Video Stream	Displays in TAC
SD Card	Inserted (optional)
Picture Settings	Enabled
RSSI	Between -20 dBm and -50 dBm
Announcements	Cleared
Status Lights	Set as desired
Accessory Lights (optional)	Attached, functional
Offline Maps	Displays in TAC
Mission Plans	Uploaded, displays in TAC
*Flight Mode	Selected
*Arm/Disarm/E-Stop	Functional

### \* Denotes Impact of Safety of Flight

immediately before a mission or in advance, dependent upon time constraints and mission needs.

## 5.10.2. FUNCTION CHECK PROCEDURES:

1. Acquire GPS signal
2. While on the ground, safely test the arm and disarm functions:
  - a. Press the ARM button
  - b. Press the DISARM button
3. Arm the system
4. Takeoff
5. Climb approx. 5-10 ft (1-3 m), out of ground effect
6. Hold for approximately 10 seconds, checking for any uncommanded change in heading

7. Yaw right 360° and return to starting point
8. Yaw left 360° and return to starting point
9. Pitch forward and return to starting point
10. Pitch backward and return to starting point
11. Roll right and return to starting point
12. Roll left and return to starting point
13. Either continue on to performing a mission, or land and disarm to start the mission at a later time

 <b>IN-FLIGHT EMERGENCY ACTIONS</b>	
Erratic Flight (Mission Mode)	<ol style="list-style-type: none"> <li>1. Switch to Position Mode.</li> <li>2. Manually land ASAP.</li> </ol>
Erratic Flight (Position Mode)	<ol style="list-style-type: none"> <li>1. Switch to Altitude Mode.</li> <li>2. Manually land ASAP.</li> </ol>
Loss of Pilot Control	<ol style="list-style-type: none"> <li>1. Attempt manual landing.</li> <li>2. E-Stop/Disarm if necessary.</li> </ol>
No GPS/ Jammed Signal	The system will default to Altitude Mode. Manually fly/land the Teal 2.
Loss of Link	<ol style="list-style-type: none"> <li>1. Record last known position.</li> <li>2. Adjust antenna to vertical position.</li> <li>3. Execute recovery procedures if Teal 2 does not RTL.</li> </ol>
RID malfunction	<p>GPS errors and Teal Settings application not running are the two most common issues.</p> <p>If GPS errors occur:</p> <ol style="list-style-type: none"> <li>1. Tap RID Emergency Status icon.</li> <li>2. View the error descriptions for GPS error status.</li> </ol> <p>If GPS is not working for the Teal 2 or TAC controller, check surroundings for obstructions.</p> <p>To check the Teal Settings application is running:</p> <ol style="list-style-type: none"> <li>1. In the Teal QGC app, Tap RID Emergency Status icon.</li> <li>2. Check for the Stale TAC System error.</li> <li>3. Open the Teal Settings application for the Teal Settings app service to start. This usually resolves the error.</li> </ol> <p>If unable to resolve RID errors, land the Teal 2 as soon as safe and practicable.</p>
6-POST-FLIGHT	
Micro SD Card	Removed
Media	Transferred
Teal 2	Powered off, inspected for damage and dirt, stowed

TAC	Powered off, stowed
Battery Packs	Removed, stowed
Mission Debrief	Complete, logged
* Denotes Impact of Safety of Flight	

### 5.10.3. COLD WEATHER OPERATIONS

When operating in low temperatures (32 °F (0 °C) or lower), battery packs that have been exposed to low temperatures for more than one hour must be pre-heated on the charger before flight.

Failure to pre-heat the battery pack before flight could reduce overall battery performance and affecting overall flight time, up to 28%.

When the cold battery pack is placed on the charger, the 5-LED bar graph will indicate that the thermal blanket is activated by showing a green LED light pattern starting in the middle moving outwards. When this animation stops and the LED indicates the solid percentage of charge, it can be used for operations. The amount of time this takes will vary upon the starting temperature of the battery pack.

### 5.10.4. HOT WEATHER OPERATIONS

During extreme hot weather conditions, it is best to keep the system and all components out of direct sunlight prior to flight. Avoid storing battery packs in hot vehicles to not exceed the recommended temperature limit of 113 °F (45 °C). If overheated, lithium-ion batteries such as the Teal Performance Battery Pack may become unstable, overheat, damage cells, and potentially catch on fire.

## 6. ARMING & TAKEOFF

### 6.1. ARMING THE DRONE

There are two ways to arm the Teal 2: either press the **left top button** on the TAC or **slide** the arrow in the slide confirmation window.

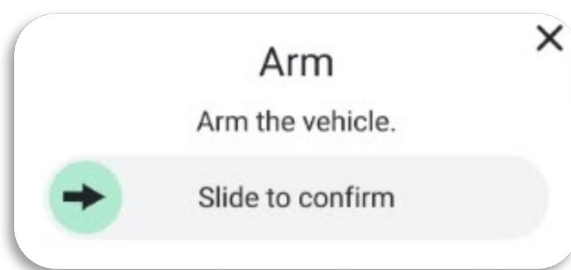

### 6.2. TAKEOFF



There are multiple ways to initiate takeoff:

**Touch** the TAKEOFF icon in the Fly Tools box or **slide** the arrow in the confirmation window.



In Mission Mode, slide the arrow to the right to takeoff and start the mission.

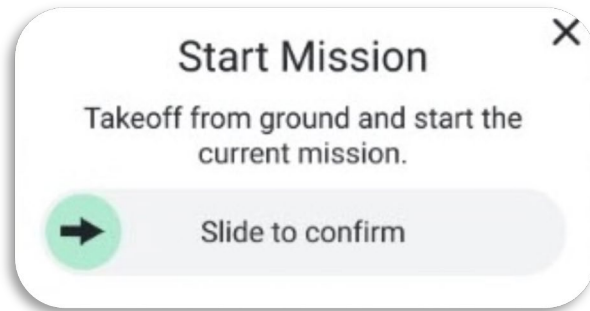

## 7. IN-FLIGHT

### 7.1. DEFAULT CONTROLS

Refer to the [Tac Controls Overview](#) screen for joystick/button locations.

#### THROTTLE UP / ASCEND

To ascend, move the left joystick straight up. The farther the joystick is moved from its centered position, the faster the Teal 2 ascends in its fixed vertical axis.

#### THROTTLE DOWN / DESCEND

To descend, move the left joystick straight down.

#### YAW LEFT / CCW

To rotate the Teal 2 counterclockwise (CCW) around its vertical axis, move the left joystick to the left.

#### YAW RIGHT / CW

To rotate the Teal 2 clockwise (CW) around its vertical axis, move the left joystick to the right.

#### PITCH FORWARD

To accelerate in a forward direction, move the right joystick up.

#### PITCH BACK

To accelerate in a reverse direction, move the right joystick down.

#### ROLL LEFT

To roll the vehicle toward the left, move the right joystick left.

#### ROLL RIGHT

To roll the vehicle toward the right, move the right joystick right.

## 7.2. FLY VIEW DETAILS

### 7.2.1. SCREEN OVERVIEW

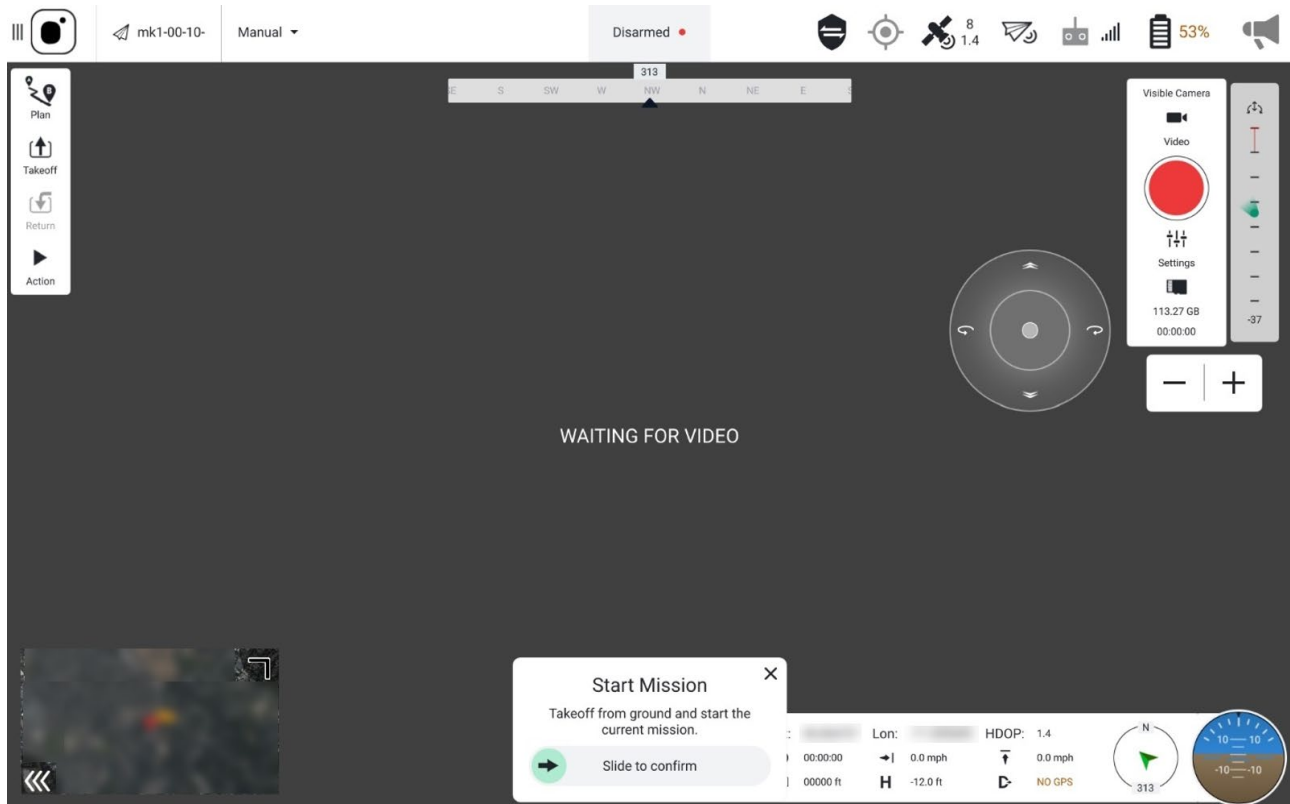

### 7.2.2. CONFIRMATION SLIDER

The Confirmation Slider box is fixed at the center-bottom of this and other screens. A context-sensitive slider appears when a critical action needs to be taken. For safety reasons, the action is intentionally made difficult to accidentally execute by forcing the user to slide (swipe right) to confirm the noted action. Press (X) to cancel the potential action which closes this box.

### 7.2.3. COMPASS HEADING

This compass heading indicator is centered just below the Main Toolbar but is only visible when video is selected to occupy the background. This indicator is not shown when the map view is selected. It indicates the heading of the Teal 2 in both the compass direction (N, S, E, W) and in the number of degrees from true north.

### 7.3. INSTRUMENT PANEL OVERVIEW



Lat: - Latitude

Lon: - Longitude

HDOP: - HDOP Values

 00:00:00 Elapsed mission time in hrs:min:sec

 0.0 Forward speed of the Teal 2 in meters/second

 0.0 Altitude change in meters/second

 00000 Odometer, indicating meters the Teal 2 has traveled during the mission

**H** 0.0 Indicates the current altitude of the Teal 2 in meters above ground (AGL)

 **NO GPS** GPS status

 Heading of the Teal 2 from true north (not magnetic)

 Attitude indicator, also known as “artificial horizon,” which shows the Teal 2 relative to the Earth’s horizon

## 7.4. CAMERA CONTROL PANEL



Video



Photo

Touch the **Video** icon or the **Photo** icon to toggle back and forth from live video to taking photos.

Alternatively, press the lower left button on the rear-panel of the TAC to toggle between video and still photos. The icons will behave as described above to indicate which mode the system is in.

### 7.2.4. PHOTO MODE

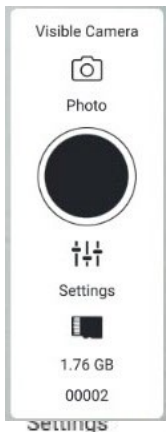

Touch the black circular icon to snap a photo. A rotating circular icon appears briefly in the middle of the button while the photo is being processed. When the photo is processed, the black circle icon will reappear.

The amount of storage remaining is indicated below the **Settings** icon, and the number of photos taken is also seen at the very bottom of the window.

Alternatively, press the front lower right button on the TAC to take photos. The icons will behave as described above to indicate whether a photo is being processed.

Touch the **Settings** icon to open the **Photo Settings** window. Here you can select either the EO or IR (Boson) cameras, select gimbal controls, and turn on/off the screen grid and gimbal control graphics on the **Fly View**.

Alternatively, press the upper left switch button on the rear-panel of the TAC to toggle the active camera between EO and IR.

### 7.2.5. VIDEO MODE

To record a video:

1. Touch the red circular trigger to start video recording. The button will change to a red square inside the circle, indicating video is being recorded.
2. Touch this red square to stop video recording. The red circle icon will reappear.



The amount of storage remaining is indicated below the **Settings** icon, and the elapsed time of the current video is also seen at the very bottom of the window. When not recording, the elapsed time counter shows 00:00:00.

Alternatively, press the front lower right button on the TAC to also start and stop video recording. The icons will behave as described above to indicate whether video is being recorded.

Alternatively, press the upper left switch button on the rear-panel of the TAC to toggle the active camera between EO and IR.

To change the video settings:

1. In Video Camera menu, touch **Settings**.
2. Open the **Video Settings** window.
3. Select for EO or IR cameras, recording format, snapshot format, camera palette, radiometric settings, gimbal controls, and screen fit.

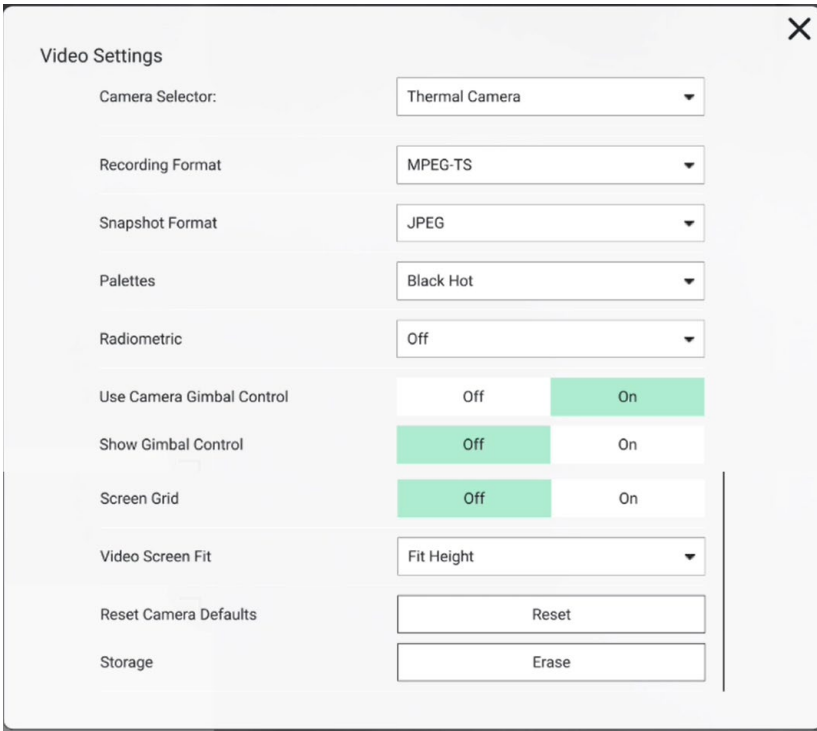

Radiometric settings show the max, min, and center temperatures.

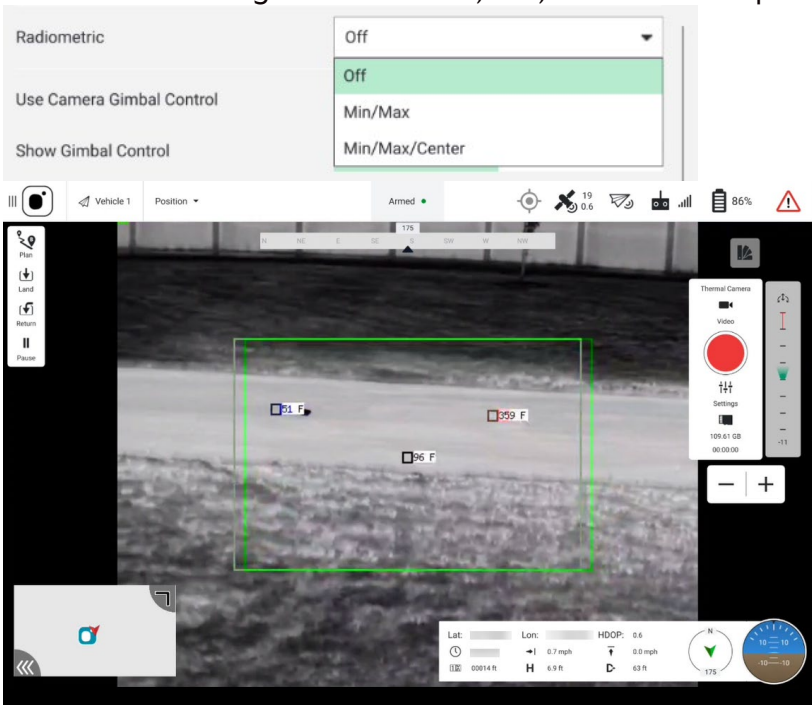

## 7.5. GIMBAL CONTROL PANEL



The gimbal pitch scale is simply a vertical bar with 8 tick marks providing a quick visual indication for the current gimbal pitch position relative to its minimum and maximum limits.

The gimbal yaw/pitch angle indicator (  ) simultaneously provides a quick visual indication of the current gimbal pitch.

This indicator also roughly shows the gimbal pitch angle by its relative vertical position on the gimbal pitch scale. The indicator slides up and down the scale as the gimbal is pitched up and down, respectively.

Touch and slide the gimbal pitch scale to directly control the gimbal pitch angle.

Alternatively, you can use the GIMBAL CONTROL CIRCLE (see the next section) or the TAC rear-panel buttons to adjust the gimbal pitch angle.

At the bottom of the panel is a number indicating the gimbal pitch angle in degrees (represented by the number 2 in the example above). The Teal 2 gimbal pitch angle ranges from about  $-110^{\circ}$  to about  $+35^{\circ}$  up, with  $0^{\circ}$  being the absolute forward camera direction.

### 7.5.1. GIMBAL CONTROL CIRCLE

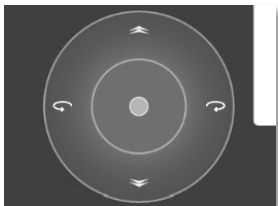

The Gimbal Control Circle is only visible when the Video view is selected. It disappears in Map view. This control provides an alternate and more intuitive way to control the gimbal's pitch.

1. Touch the bullseye to change the pitch and yaw of the gimbal.
2. The up/down directions control the pitch.
3. Release to stop the movement of the gimbal at that current position.

Alternatively, **press or tap the upper right switch button** on the rear-panel of the TAC to continuously rotate the camera angle up until the button is released or until it reaches its maximum up position. Momentary taps of this button rotate the camera angle up by about  $7-8^{\circ}$  per tap.

Alternatively, **press or tap the lower right switch button** on the rear-panel of the TAC to rotate the camera angle until the button is released or until it reaches its maximum down position. Momentary taps of this button rotate the camera angle down by about  $7-8^{\circ}$  per tap.

### 7.5.2. ZOOM IN / ZOOM OUT CONTROLS



Below the camera and gimbal control panels are the zoom in and zoom out controls. The EO camera has 12 levels of digital zoom, the default being the fully zoomed-out level. The IR camera has 11 levels of digital zoom. Each "+" or "-" button press changes the zoom by one level.

Alternatively, **move the front right 4-position switch** on the TAC to the left to zoom in and to the right to zoom out.

## 7.6. PHOTOS SCREEN

All photo functions must be enabled before flight or else the media will not be stored locally on the TAC and will not be transferrable after the mission.

However, the tradeoff to having the media stored locally on the TAC during flight is a reduction of bandwidth which could degrade the quality of the media seen on the TAC fly view during the mission.

### 7.6.1.ENABLE PHOTO SETTINGS INSTRUCTIONS

If possible, we recommend storing media on the SD card, but realize some security protocols will not allow this.

1. Touch the **Main menu** icon.
2. Select **Settings** at the bottom of the screen.
3. Select **General**.

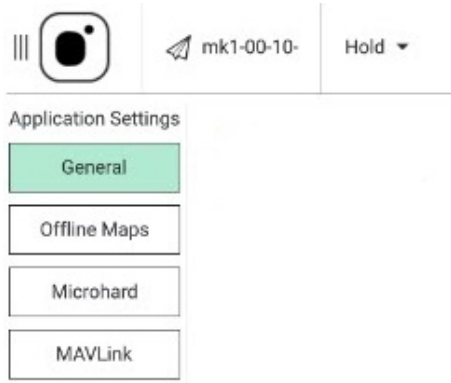

4. Scroll down to **Picture Settings**.

Picture Settings

Download Full Res Image In Flight

5. Check the **Download Full Res Image In Flight** box.

### 7.6.2. PHOTO SCREEN SETTINGS

1. Touch the **Main menu** icon at the top of the TAC screen.

## 2. Select Photos.

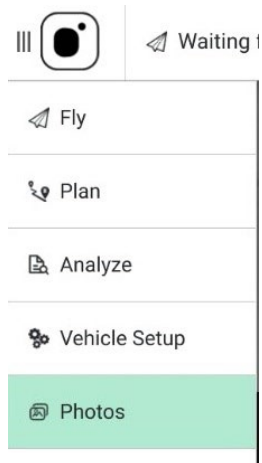

In the **Photos Screen** customize the following functions:

- Take EO & IR snapshots and download them immediately in-flight to the TAC
- View thumbnails of downloaded EO & IR photos
- View a selected photo at full resolution
- View metadata of a photo
- Delete downloaded photos from the TAC

### 7.6.3. TAKING A PHOTO



A camera icon is fixed in the lower right-hand corner of the Photo screen. Touching this icon snaps a photo on the vehicle and downloads it immediately to the TAC.

Pressing the front right momentary switch on the TAC will also either take a photo or start recording video.



A symbol appears when the camera icon is touched but download is not enabled. Ensure that the photo functions in the **Settings** are enabled as instructed in the previous page.

The background of the Photos screen is largely a blank black screen, until it is populated with photos taken from the Teal 2. Snapshots appear sequentially left-to-right and top-to-bottom on the Photos screen.

### 7.6.4. DELETING A PHOTO



**Touch** any photo in the photos screen to enable a selection box in the upper-right corner of each photo and the trash can icon in the lower-left corner. The box for that photo immediately turns green and indicates that it is selected for deletion. All others are black until selected. Immediately touching that first photo again causes all the selection boxes to disappear. All selected photos can be deselected one at a time. As soon as the last selected photo is touched to deselect it, all the selection boxes disappear.

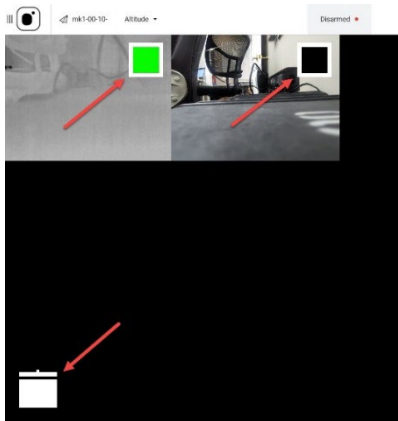

Once photos are selected for deletion, touch the trash can icon.



**Note:** Deleting photos from the TAC does not delete the original photo stored on the Teal 2.

### 7.6.5. VIEWING A PHOTO & METADATA

Select an individual photo for viewing by touching that photo. The selected photo will fill the entire Photo screen.



In the upper left of the individual photo view is a metadata icon. **Touch** this icon to display the timestamp of when the photo was taken. **Touch** the icon again to cause the metadata to disappear.

Above the metadata icon is the exit (X) icon. **Touch** this icon to exit the individual photo view and return to the main Photo screen that shows all the downloaded photos.

In the lower left of the individual photo view is a trash icon. **Touch and hold** this icon for about 1 second to delete the photo from the TAC photo screen.

## 8. LANDING & DISARMING

Please review the following functions to appropriately land and disarm the Teal 2 in both normal and emergency situations.

### 8.1. LAND

The land function is used under normal circumstances and brings the Teal 2 straight down from its immediate position in a controlled descent. The Teal 2 automatically disarms when on the ground for 3-4 seconds.

To land at the current position at any time:

1. Touch the **Land button** in the Fly Tools box.

2. Confirm landing by moving the confirmation slider to the right.

Alternatively, **hold the left joystick** that controls throttle in a continuous down position until the Teal 2 automatically disarms when on the ground for 3-4 seconds.

## 8.2. RETURN TO LAUNCH (RTL)

The RTL function is used under normal circumstances and initiates the pre-programmed landing sequence to a pre-determined takeoff / landing location.

The RTL settings can also be customized in the Safety Settings screen for abnormal flight situations. These pre-determined fail-safes will automatically trigger a RTL.

The Teal 2 automatically disarms when on the ground for 3-4 seconds.



To initiate the RTL sequence via the TAC soft key:

1. Touch the **Return button** in the Fly Tools box.
2. Move the confirmation slider to the right. Alternatively, press the **front left momentary switch button**.

## 8.3. EMERGENCY STOP AND DISARM

The Emergency Stop (E-Stop) function is designed to immediately cut off power to the motors and cease all momentum of the Teal 2. This causes the Teal 2 to fall exactly where the motors lose power, resulting in no control over where the Teal 2 lands.

This function is intended to be used in emergency situations only, and not for regular landing/disarming situations. The airframe will be unable to recover itself back into flight once the E-Stop has been activated and damage to the Teal 2 can be significant.

To disarm the Teal 2 via the E-stop button, flip open the right top-panel guard door, and press the red button.

### WARNING!



**The E-Stop will shut off propulsion and the vehicle will immediately fall from the sky. This may result in:**

- Partial or complete loss of the airframe, camera, gimbal, arms, motors, payloads and/or props upon impact.
- Partial or complete loss of data.
- Damage to property on the ground upon impact.
- Significant injury or death of person(s) upon impact.

## 9. POST-FLIGHT

Be sure to inspect the Teal 2 for any damage after landing. It is recommended to power off and remove the battery packs from both the Teal 2 and TAC before stowing the system.

However, be sure to extract the flight logs from the Teal 2 before powering it off. Flight logs can be extracted at a later time, until they are permanently deleted from the Teal 2. Once the flight logs are transferred from the Teal 2 to local storage on the TAC, they can then be transferred to either a removeable USB-C device or to a PC via USB-C cable.

Photos can be easily transferred from the Teal 2 if the SD card was inserted and used during flight. Remove the SD card from the Teal 2 and insert it into the SD adapter, if necessary, and then be insert the adapter or card into a PC. If photos were enabled on the TAC, the photos will also be stored locally to the TAC and then can be transferred to either a removeable USB-C device or to a PC via USB-C cable.

## 9.1. FLIGHT LOGS

Some suggestions of what to document in your paper or digital flight log:

- Date & time
- Environmental conditions
- Teal 2 serial number
- TAC serial number
- Software versions used
- Mission objective and operations performed
- The RPIC
- Damage sustained and/or maintenance needed

## 9.2. DOWNLOAD FLIGHT LOGS: TEAL 2 → TAC

To download flight logs over the Teal 2 wireless network to the TAC, open Teal QGC on the TAC.

1. Open Teal QGC
2. Tap the **Main menu** icon at the top of the screen.
3. Select **Analyze**.
4. A **Log Download** screen will appear.
5. Select **Refresh** at the right of the screen to ensure all available files are displayed on the screen.
6. Select the file that you want to download by tapping on the screen on that file. Files are distinguished by time, date, and file size.



**Note:** Although the software will allow multiple files to be selected, it is recommended to download one file at a time to avoid any timeout errors.

7. Select **Download** at the right of the screen.
8. A screen pops up to save the file to a directory. This is not necessary and disappears after tapping OK.
9. Select **OK** to continue.

Once the file is finished downloading, the file's status on the screen shows as Downloaded and will be available to transfer off of the TAC.

## 9.3. TRANSFER LOG FILES: TAC TO REMOVEABLE USB-C DEVICE

1. Complete the previous **Download Flight Log** instructions in Section 10.2.
2. Insert a USB-C removeable storage device into the port located at the top of the GCS.
3. Return to the tablet home screen.
4. Touch the **My Files** icon. Follow the path to the logs: Internal Storage > Teal QGC > Logs
5. Press and hold the files you want to transfer until a checkmark next to the files appears.
6. You will be able to **Move**, **Share**, or **Copy** the files.



**Note:** Selecting **Share** will transfer the files to another GCS.

7. Select **Move**.
8. Select **USB Storage**. This may show the given name of the storage device.
9. You may need to scroll down or collapse the file path to see this option.
10. Select **Move Here** at the bottom right corner of the GCS screen.
11. A file with date, time, and orange “N” symbol will appear when the transfer is completed.
12. Remove the USB-C storage device when finished.

## 9.4. TRANSFER LOG FILES: TAC TO PC

Before downloading media:

- Ensure the system has power and is paired and communicating prior to proceeding.
- Use a fully charged battery pack in both the Teal 2 and the TAC.
- Do not power off the TEAL 2 or the TAC at any time during the process.

To download flight logs:

1. Make sure the Teal 2 and TAC are paired.
2. Download the log files from the Teal 2 to Teal QGC.
  - a. Open Teal QGC.
  - b. Tap the **Main menu** icon in the upper left corner.
  - c. Tap **Settings**.
  - d. Tap **Analyze**.
  - e. This opens the download tab.
  - f. Tap the file to download.
  - g. Tap **Download**.
  - h. A downloaded message appears when the download is complete. The flight logs are now saved on the GCS.
3. Plug in a USB drive into the USB port on the TAC.
4. Open the **My Files** application.
5. Tap **Internal storage**.
6. Tap **TealQGC**.
7. Tap **Logs**.
8. Select the files to download to the USB drive. Press and hold the file until it is selected.
9. Tap **Copy** at the bottom of the screen.
10. Select the USB drive in the left side bar.
11. Tap **Copy here** at the bottom of the screen.
12. The logs are now on the USB drive. Remove the USB drive. Plug in the USB drive into the computer to download the files onto the computer.

## 9.5. TRANSFER MEDIA: SD CARD DRONE TO PC

If the SD card was inserted into the Teal 2 before flight, the photos and videos will be saved to the SD card. The files can be transferred directly to a PC.

1. Remove the SD card from the Teal 2.
2. Insert the SD card into the SanDisk SD adapter that was provided in the spares kit, if needed. Any SD adapter will suffice.
3. Insert the SD adapter or SD card into the PC.
4. On your computer, open a file browser such as Explorer.
5. Find and follow the file path to the logs.
  - a. The video will have a .ts file extension
  - b. The photos will have a .jpg file extension and will be labeled IMG.
6. Each photo and video file will be labeled with either EO or IR.
7. Move or copy the log files from the directory above to the desired location on the PC.

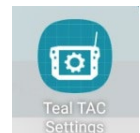

## 9.6. TRANSFER PHOTOS: TAC TO USB-C DEVICE

1. Tap the **My Files** icon. Follow the path to the logs: **Internal Storage > Teal QGC > Photo**
2. Press and hold the files you want to transfer until a checkmark next to the files appears.
3. Select **Move, Share, or Copy**.



**Note:** Select **Share** to transfer the files to another GCS.

4. Select **USB Storage**. This may show the name of the storage device.
5. Select **Move Here** at the bottom right corner of the GCS screen.
6. A file with date, time, and orange N symbol will appear when the transfer is completed.
7. Remove the USB-C storage device when finished.

### 9.6.1. TRANSFER MEDIA FROM THE GCS TO A PC

To transfer other media files, follow the same steps for downloading flight logs.

## 9.7. CLEARING MEDIA

We recommend clearing all media from the Teal 2 after each flight. After media has been successfully transferred:

1. Power on and connect the TAC and Teal 2 without a media card inserted.
2. Select the **Settings** icon in the **Camera Control Panel** in the **Fly View**.
3. Select **Visible Camera** from the drop-down menu.
4. Scroll to the bottom.
5. Select **Erase**.
6. This will delete all the EO photos and videos on the Teal 2.
7. Select **IR Camera** from the drop-down menu.
8. Select **Erase**.
9. This will delete all the IR photos and videos on the Teal 2.



# 10. POST-INCIDENT REPORT PROCEDURES

## 10.1. IMMEDIATE POST-INCIDENT PROCEDURES

Document the following items after an event or failure resulting in a crash:

1. Determine if the area is safe; if the situation is secure, then proceed.
2. Do NOT touch the Teal 2 yet!
3. Document the date and time.
4. Take photos of the Teal 2 to include in the report.
5. Is the Teal 2 still powered on?
  - a) Do you need to hit the E-Stop and disarm?
  - b) Is the battery on (look at the light on the Teal 2, but do not touch)?
  - c) Are the white LED lights on the side of the Teal 2 still on?
  - d) Is the fan on the Teal 2 running?
  - e) Is the gimbal still trying to stabilize?
6. Is the Teal 2 still connected to the TAC?
7. Is there still a video feed and telemetry being reported?

8. Does the Teal 2 appear safe to handle? If yes, carefully pick up the Teal 2 and power off the battery if it is running.
9. Remove the battery pack. If the battery does not shut off, remove the battery pack while it is still powered on:
  - a) Set in a safe place
  - b) Once some time has passed, check to see if the battery pack is still warm
10. Are the arms still locked?
11. Are the arms damaged?
12. Do the motors appear to be damaged?
13. Are the motors still freely moving or do they bind?
14. Is the gimbal/camera damaged? Check the gimbal/camera wires and connectors.
15. Are there cracks or damage to the body of the airframe?
16. Is the battery connector on the bottom of the Teal 2 still attached?
17. Collect any loose parts and put them in a bag to keep together with the Teal 2.

## 10.2. DOCUMENTING YOUR INCIDENT REPORT

Document these items that may be required in your incident report:

1. Document the TAC and Teal 2 serial numbers.
2. What firmware version is on the Teal 2?
3. What firmware version is the Teal QGC?
4. Describe the flight you were trying to perform: Mission, Manual, Position, or Altitude flight mode, climbing, rolling, etc.
5. Describe your observations of how the flight performed.
6. Describe the environment (*wind, snow, hot, cloudy, sunny, raining, crowded area, open fields, etc.*).
7. Describe the incident:
  - a) How did it fall?
  - b) Was it making noise as it fell? Was it silent?
  - c) Did the Teal 2 tumble or was it a controlled crash?
  - d) Was the flight stable before this?
  - e) Were there any warnings or errors on the TAC?
  - f) What was the sequence of events? Include what you expected the Teal 2 to do and what the Teal 2 did.
8. If the Teal 2 can still safely power on and connect to the TAC, are you able to download the logs from the Teal 2 onto the TAC? If not, Teal Customer Support can extract the logs for you.
9. Send the flight logs to Teal Drones Customer Support at [support@tealdrones.com](mailto:support@tealdrones.com) and include them with incident report.

## 10.3. FILE AN ACCIDENT REPORT

For more information of the rules and regulations of accident reporting, and for up-to-date reporting procedures, please visit the FAA's *Teal 2 Pilot's Accident Reporting* page at:

<http://Teal2pilots.org/knowledge-center/14-cfr-part-107-knowledge-center/accident-reporting/>

# 11. TEAL 2 Teal 2 DETAILS

## 11.1. ARCHITECTURE & RATIONALE

The Teal 2 is designed to be vertically integrated and fully modular, ensuring that each payload, propulsion, and battery system can be quickly repaired, replaced, and upgraded. Each spares kit contains necessary parts and tools required to immediately make repairs while in the field.

See the Field Repair and Maintenance appendix located at the end of this manual for more information on repairing and replacing parts.

### 11.1.1. TEAL 2 SYSTEM POWER

The ON/OFF power switch for Teal 2 is built into the battery pack. A 4-second press-and-hold of the battery power button turns the pack on or off. The battery pack must be removed from the Teal 2 to be recharged. The battery pack is not serviceable in the field but is easily removed and replaced.

#### CAUTION!



The Teal 2 does not support a battery pack hot-swap. Be sure to power down the battery pack before removing and replacing it.

### 11.1.2. ANTENNAS

The Teal 2 antenna is highly flexible, providing for greater crash survivability. When placed in its tactical case, the case lid can be closed, bending the antenna(s) down to the top case. The antennas are permanently attached to the top cover and are not field-replaceable.

### 11.1.3. ROTOR ARMS

The Teal 2 has foldable and replaceable rotor arms. The arms fold down and under the bottom of the Teal 2, even with the propellers attached. No latching or unlatching is necessary when folding the arms. When folding, the arms give at a torque of about 7 in-lbs. Locking the arms in the extended (flying) position requires a torque of about 3 in-lbs.

### 11.1.4. PROPELLER MOTORS

A custom brushless DC motor is mounted to each folding arms. These 3-phase motors spin at speeds up to 14,000 rpm. Optimized motor drive algorithms maximize the motors' power, efficiency, and audible signature. Note that individual motors cannot be replaced if damaged – only complete arm assemblies can be replaced.

### 11.1.5. PROPELLER ASSEMBLIES

Propeller assemblies are easily replaced in case of breakage with a simple no-tools push-and-twist method and are keyed so that a CCW one cannot be mounted to a CW hub and vice-versa. Replacement arms are prewired with the motor installed and are easily swappable in the field by removing a single T8 Torx screw.

### 11.1.6. MULTI-FUNCTION BUTTON

A multi-function button is used during the process of pairing Teal 2 to the TAC, among other functions, including future functionality.

### 11.1.7. RESET/ FACTORY RESTORE BUTTON

The reset / factory restore button is recessed internally and is accessed through a pin hole to prevent accidental actuation. A paper clip or other small rigid pin can be used to actuate it. Pressing and holding this switch for at least 10 seconds before releasing initiates the following functions:

- Clears all media on either the SD.
- Clears all pairing information, causing a full radio settings re-program on the next pairing attempt (but does not clear the radio settings that are active on the radio).
- Sends a MAVLink message to PX4 to reset its parameters to default.
- Clears flight logs.

### 11.1.8. TIME OF FLIGHT SENSOR

An infrared ground-distance sensor on the bottom of the Teal 2 works in conjunction with other on-board (GPS and barometric pressure) sensors to determine the distance to the ground to assist in landing.

The photo-diode emitter in this ground-distance sensor beams down infrared light, and a photo-diode receiver senses the reflections from that light to detect the distance to ground by measuring the “time of flight” of that light. It starts sensing the ground at about 12-15 meters high.

### 11.1.9. STOCK PAYLOAD

The stock payload on the Teal 2 is a dual-axis (pitch and roll) gimbaled FLIR Hadron 320 EO/IR camera module. The payload electrical interface to the Teal 2 utilizes plug-in cables for ease of swapping the payload.

The gimbal’s pitch angle ranges from +35° to -110°, and its roll angle ranges from +25° to - 25°. The roll function is automatic, so that it rolls in the opposite direction as the Teal 2, allowing for the camera to remain horizontal in roll and pitch up to 25°.

The electro-optical portion of the camera is a 12 Megapixel CMOS image sensor combined with an 80-degree horizontal field-of-view (HFOV) lens. The EO camera takes 4,000x3,000 video as well as 12 MP resolution still images in JPEG or TIFF format. Optical video from the camera is stored in the Teal 2’s on-board flash memory or SD card.

The infrared portion of the camera has a 34-degree HFOV and captures video in a 640x512 format. The IR camera also has a built-in shutter for automating non-uniformity correction, which reduces image blurring and artificial ghosting. IR video is stored in on-board flash memory or SD card in 640x512 format.

The EO/IR camera module provides simultaneous EO and IR video streams to the Teal 2 CPU, formatted as an H.264 elementary stream video within a MPEG2 Transport Stream. Either optical or IR video can be selected (on the TAC) to be transmitted over the radio link in a compressed format. Transmitted optical video is sent in a 720p (progressive scan) format. Video latency to the TAC has been minimized to ensure safe operation in confined areas.

### 11.1.10. MICRO SD CARD SLOT

The I/O port cover door swings open to expose the I/O ports. The port on the left is a Micro SD card slot. Teal’s Field Repair Kit includes one 128 GB Micro SD card and one SD card adapter that can be used to store and transfer media files from the Teal 2.



Using the Micro SD card for storage is not a secure method of transferring confidential media files, but currently is one of the limited options for doing so. Be sure you understand the risks of losing the content of the SD card if



the Teal 2 is lost or not recoverable.

### 11.1.11. AUXILIARY LIGHTING

The Teal 2 includes an illumination panel on each right and left side of the airframe. These panels are designed to spread light vertically from the bottom to the top of the airframe to be visible from nearly all angles in flight. The stock Teal 2 lights may not be bright enough or have appropriate directivity for some applications such as anti-collision, search and rescue, or line-of-sight navigation at a distance. For these situations, it is desirable to attach third-party auxiliary lighting to the airframe.

### 11.1.12. AUXILIARY LIGHTING PLACEMENT

The maximum weight of all auxiliary equipment that can be attached to airframe is 75 grams and must be securely attached to not cause any vibration.

Place the auxiliary light(s) toward the vehicle's natural CoG. This will result in the least amount of degradation to flight performance.

The Center of Gravity (CoG) of Teal 2 is essentially dead center of the vehicle (the intersection point of the two (2) lines drawn between the centers of diagonally opposite props). The closer the weight distribution of the attached equipment maintains the original CoG, the better the aircraft will perform.

Care should be taken to avoid physical or electromagnetic interference. Do not place items containing metal near the magnetometer, located at the rear tip of the vehicle.

Spin the props to make sure that they do not come in contact with the desired location of the mounted light(s). Maintain at least 10mm clearance from tips of the prop blades to the light(s). Select the location of the light(s) while the gimbal protective cover is installed on the Teal 2 to ensure the added attachment does not interfere with the cover.

Verify that the gimbal operation, gimbal cover, battery pack, propeller assemblies, and rotor arms are not mechanically impeded by the attached lights.

### 11.1.13. REMOTE IDENTIFICATION

Remote Identification (RID) transmits AV and GCS information over Bluetooth consistent with the requirements of 14 CFR Part 89. Not all systems have RID.

Teal 2 is tested and compliant with 14 CFR Part 89 as a Standard Remote ID Equipped UAS.

The RID Emergency Status Indicator icon shows the current status of the Teal 2. In the event of RID broadcasting failure, an emergency status appears on the TAC. If the Teal 2 detects an error during flight, RID alerts the pilot and returns the Teal 2 to the landing point.

There are three RID status indication colors:

- Green – Ready to fly.
- Yellow- Emergency. May be automatically detected by the Teal 2 or manually designated by the pilot.
- Red - Remote ID is inoperable or not ready. Red indicates the Teal 2 is not transmitting data. The Teal 2 cannot arm or fly. Tap the Vehicle Messages icon to learn more.  
If the RID status turns red during flight, the Teal 2 can continue flight. Land the Teal 2 as soon and as safe and practicable. Once the Teal 2 lands, it cannot relaunch until the RID issue is resolved.

To operate RID:

1. Take the Teal 2 outside and power on the Teal 2.
2. Power on the ground station TAC controller.

3. On the TAC, swipe from the right side of the screen to access the Teal Settings application.
4. Tap the Teal Settings application to launch the app.
5. Use the center bar slider to minimize the the TAC app and keep it running in the background.

The RID status indicator turns green when the RID is operating. RID does not allow flight indoors. RID requires valid GPS lock signal to operate. Changing location or turning off the Teal 2 for more than 24 hours loses the GPS lock. It may take three minutes to reestablish the GPS lock.

Errors display in hexadecimal codes. Common RID errors include loss of GPS signal and not running the TAC app. In the event of errors during flight, land the Teal 2 immediately.

To ensure accurate RID data, the pilot must:

- Position the TAC no closer than 100' horizontally from buildings or structures during flight.
- Make sure the TAC is oriented and operated with the screen parallel to the ground.
- Ensure there are no obstructions which obscure the TAC from full view of the sky.

#### 11.1.14. DISCONNECTING A PAIRED VEHICLE FROM THE TAC

Disconnecting a paired vehicle from the TAC does not delete the pairing. This allows users to disconnect from vehicle and connect to another vehicle. See the **Unpairing** instructions below if permanent unpairing is needed.

1. Open the **Teal Settings** application.
2. Select the vehicle to disconnect.
3. Tap **Disconnect**.

#### 11.1.15. UNPAIRING THE SYSTEM

Unpairing the Teal 2 from the TAC drops the secure pairing relationship.

1. Open Teal Settings application.
2. Tap the vehicle to disconnect.
3. Tap **Remove vehicle from this device**.

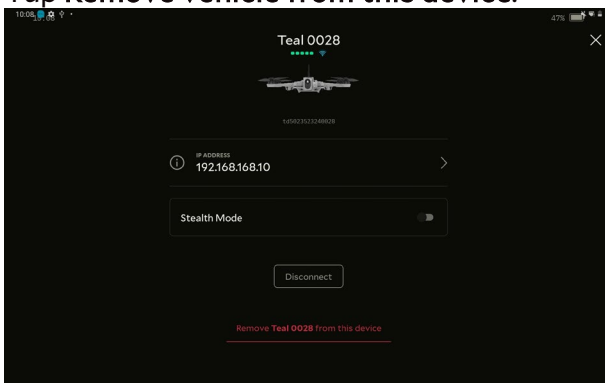

4. A pop up appears asking if you are sure you want to remove the vehicle. Tap **Remove**.

## 11.2. BINDING THE VEHICLE AND TAC

Each Teal 2 and TAC are paired over a secure wireless network. All communicated data is encrypted between the Teal 2 and TAC over the AES-256 encrypted wireless network.

Only one wireless modem link is available between the TAC and the Teal 2. Both the Teal 2 and the TAC use the Microhard Pico series pDDLxxxx-AES256 modem. The Microhard Pico modems support Advanced Encryption Standard with block lengths of 256 bits.

Radio encryption is managed through the TAC radio's user interface (UI). Access to the radio's configuration interface is secured through the QGroundControl application with a valid account name and password. Once logged into the TAC, the user selects a unique network ID to allow linking to and pairing with the Teal 2. Once joined to the same network, the wireless network forms a wireless encrypted closed network between the air and ground systems.

### 11.2.1. PAIRING ADDITIONAL VEHICLES

Users can have multiple vehicles paired with a single TAC. Only one vehicle can be connected for operation at a time.

To pair another vehicle:

1. Open the **Teal Settings** application.
2. Tap **Pair+**.
3. On the vehicle to pair, hold the pairing button for five seconds.
4. In the app, tap **Continue**.
5. On the TAC, select the drone to pair.
6. Tap **Pair with this device**.
7. Follow the in app pairing instructions.
8. Once paired, there is a **Successfully connected to Vehicle** message.

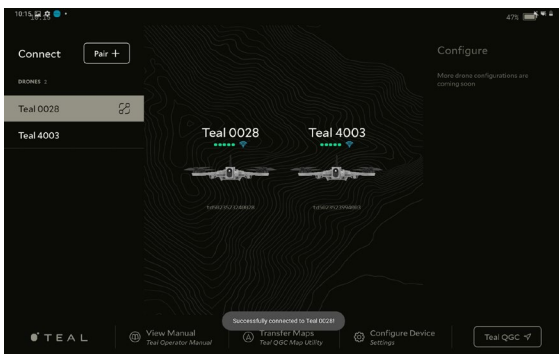

The paired vehicles are listed on the left side of the screen. The connected vehicle is highlighted grey and has a connected icon next to it.

### 11.3. CALIBRATING THE DRONE

The Teal 2 will arrive already calibrated, and needs to only be calibrated when:

- You have traveled over 50 miles (80 km) or to a new geographical location.
- You have seen significant flight instability, such as “toilet-bowling” or horizontal position wandering greater than 10 ft (3 m).
- The system has prompted you to perform a calibration.



Follow along with our instructional video, *Calibrating Drone Sensors: Teal 2 Drone* on our website at: <https://tealdrone.com/support/training-video>

### 11.3.1. CALIBRATING THE COMPASS

1. Connect the vehicle and TAC.
2. Touch the **Main menu** icon.
3. Select **Vehicle Setup**.
4. Select **Sensors**.
5. Select **Compass** to calibrate the magnetometer.
6. Click **OK** in the top right of the screen to begin.
7. The first tone from the vehicle alerts you to begin.
8. Follow the rotation instructions on the TAC screen.
9. Select **Reboot Vehicle** when finished. This step is highly recommended. Not rebooting the vehicle may cause erratic behavior.
10. Reestablish connection between the TAC and the Teal 2.

### 11.3.2. CALIBRATING THE GYROSCOPE

1. Connect the vehicle and TAC.
2. Touch the **Main menu** icon.
3. Select **Vehicle Setup**.
4. Select **Sensors**.
5. Place the Teal 2 on a flat, level surface.
6. Select **Gyroscope**.
7. Click **OK** in the top right of the screen to begin.

This should only take a few seconds to complete.

### 11.3.3. CALIBRATING THE ACCELEROMETER

1. Connect the vehicle and TAC.
2. Touch the **Main menu** icon.
3. Select **Vehicle Setup**.
4. Select **Sensors**.
5. Place the Teal 2 on a flat, level surface.
6. Select **Accelerometer**.
7. Click **OK** in the top right of the screen to begin.
8. Follow the instructions on the TAC screen. As each orientation completes, move the Teal 2 into the next position as prompted on the TAC screen. When all six positions are complete, you may return to Fly View.

## 12. TEAL AIR CONTROL (TAC) DETAILS

### 12.1. ARCHITECTURE & RATIONALE

The TAC is a critical system serving as the UI, AV manager, system network manager, media manager, mission program manager, and storage device. As the primary UI, the TAC provides physical controls for the air vehicle to be flown manually with first-person view (FPV) over a low-latency video stream. Using the built-in tablet's touch screen, the user can program autonomous missions and manage other more complex functions through an intuitive custom UI.

As a stand-alone system, all high-resolution mission media and mission telemetry data are securely retrieved from the air vehicle, stored, and replayed by the TAC.

#### 12.1.1. SERVICEABILITY

The TAC's mechanical design is straightforward, having only four major chassis components: a clamshell chassis front and rear, an internal tray to secure the Samsung tablet, and a small externally accessed door removable with two Torx screws to access the radio modem for repair.

### 12.1.2. RF COMMUNICATION / RADIO MODEM

The TAC contains associated radio connected internally to a Microhard pMDDL2450-AES256 modem. Radio encryption is initiated and managed through the TAC UI. Once a Teal 2 pairs to a TAC, an encrypted Closed Network between the air and ground systems is automatically formed.

Before operating multiple vehicles, deconflict the RF frequencies. Each RF radio channel for each vehicle should be at least 20 MHz away from the other vehicle frequencies. If one vehicle is using 5 MHz, the next vehicle needs to use 25 MHz.

The 1.8 GHz has channels 4-56. The 2.4 Ghz has channels 6-76.

### 12.1.3. LAN / DRONE

The user can select to either connect the TAC to the Teal 2 or wi-fi.

### 12.1.4. I / O

The TAC includes a high-speed USB-C 3.1 port; future functionality and features may be developed.

### 12.1.5. SAMSUNG TABLET

The TAC system uses a Samsung Galaxy Tab Active Pro tablet, which is MIL-STD-810G certified and IP68-rated. It features a large, WUXGA (1920x 1200) resolution, 10.1" touchscreen and is super-bright and sunlight-visible with a 550-nit rating. The audio vents comply with the IP53 rating.

### 12.1.6. TAC SYSTEM POWER

The main on/off system power switch for the TAC is built into the battery pack. A 4-second press-and-hold of the battery power button turns the pack on or off. The battery pack must be removed from the TAC to be recharged. The battery pack is not serviceable in the field but is easily removed and replaced.

#### CAUTION!



The TAC does not support a battery pack hot-swap.

Power down both the tablet and the battery pack before removing and replacing the battery pack from the TAC.

### 12.1.7. TABLET POWER

After powering on the TAC main system power via the battery button with a 4-second press-and-hold, the tablet must then be powered on via its tablet power button with a 2-second press-and-hold.

When the tablet power is on, a quick tap on the tablet power button puts the tablet to sleep. When asleep, a quick tap on the tablet power button, or a double-tap on the screen, wakes it up.

## 13. SYSTEM SOFTWARE DETAILS

### 13.1. ACCESSING THE APPS

The TAC is built around a Samsung Galaxy Tab Active Pro tablet running the Android operating system.

### 13.2. TEAL QGC APP

Teal QGC is the ground control application software running in Android on the TAC. It is the primary user application for flying the Teal 2. Teal QGC launches by default when the TAC is powered on.

Teal QGC is Teal’s customized version of Auterion’s open-source QGroundControl (<https://auterion.com/>) with customizations and enhancements added to optimize robustness and usability.

### 13.2.1. GENERAL SETTINGS

The Teal QGC general settings screen is used to view and manage a variety of Teal QGC software application settings.

**UNITS:** Set units of measurement for distance, area, speed, and temperature. Choose between feet and meters, imperial and metric, and Celsius and Fahrenheit.

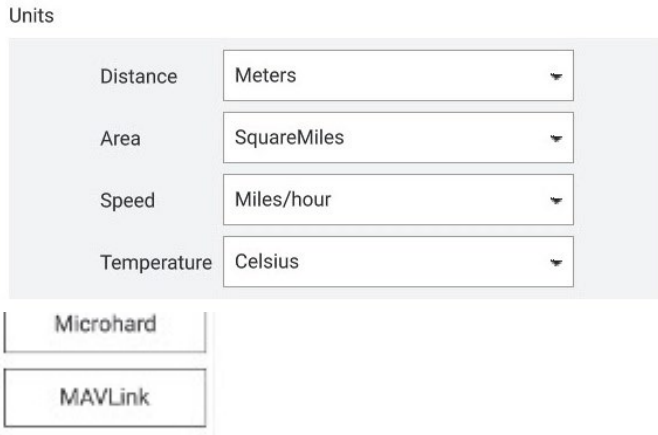

**MISCELLANEOUS:** Customize or enable/disable the following features:

- Language
- Outdoor/indoor read modes (light/dark screen modes)
- Map provider
- Map type
- UI scaling
- Display MGRS coordinates
- Mute all audio output
- Autoload missions
- Clear all settings on next start
- Turn on/off the embedded virtual keyboard

- Announce low battery charge levels

#### Miscellaneous

Language: System

Color Scheme: Outdoor

Map Provider: Bing

Map Type: Hybrid

UI Scaling: - 79% +

Use Vehicle Pairing

Display MGRS coordinates

Mute all audio output

AutoLoad Missions

Clear all settings on next start

Use Embedded Virtual Keyboard (requires restart)

Announce battery lower than 20 %

**DATA PERSISTENCE:** Disabling this option will result in telemetry logging and map tile caching to not be written to disk. This can be useful for security reasons but can also result in unintentional data loss.

#### TELEMETRY LOGS FROM VEHICLE:

- Saves telemetry logs to the vehicle which can later be downloaded to the TAC.
- Saves telemetry logs to the vehicle even if the vehicle was never armed which can later be downloaded to the TAC and can be useful for troubleshooting or other purposes.
- Saves telemetry logs in a CSV format for importing data into other programs for data analysis, such as spreadsheets.

**FLY VIEW:** Customize or enable/disable the following features:

- Use preflight checklist
- Keep map centered on the vehicle
- Show telemetry log replay status bar
- Use vertical instrument panel
- Show additional heading indicators on compass
- Set GO TO location max distance
- Enable new gimbal controls
- Turn on/off gimbal joystick speed factor
- Set gimbal slide speed factor

**PLAN VIEW:** Entering the DEFAULT MISSION ALTITUDE value here sets the altitude in the PLAN SCREEN at which missions fly by default, unless otherwise specified.

**CURSOR ON TARGET (COT):** This is currently still under development at the time of this publication.

**VIDEO & VIDEO RECORDING:** These settings are automatic and are not customizable at the time of this publication.

Video

Video Source

RTSP URL

Aspect Ratio

Disable When Disarmed

Show Video On Second Screen  (Requires Restart)

Video Recording

Auto-Delete Files

Max Storage Usage  MB

Video File Format

**PICTURE SETTINGS:** Configures full-resolution images whenever a snapshot is taken.

Picture Settings

Download Full Res Image In Flight

**CAUTION!**



This function must be enabled before flight or else photos will not be stored locally on the TAC and will not be transferrable after the mission.

**TEAL QGC SOFTWARE VERSION:** The current version of the Teal QGC software version that has been downloaded onto the TAC. TAC updates are automatic.

**13.2.2. MICROHARD SETTINGS**

|||  mk1-00-10- Hold ▾

Application Settings

- General
- Offline Maps
- Microhard**
- MAVLink

General

Connection Status

The Microhard settings screen is where to enable/disable the TAC’s Microhard radio and to view the signal strength of the TAC and the Teal 2.

**GENERAL:** When the Enable Microhard box is checked, the Connection Status sub-group appears below it. Otherwise, Connection Status disappears when the Microhard radio is disabled.

**CONNECTION STATUS:** When a vehicle is connected to the TAC, a **Connected** message is displayed and the real-time RSSI value for both the Teal 2 vehicle and the TAC are displayed.



When the Microhard is enabled, but no vehicle is connected to the TAC, a NOT CONNECTED message is displayed.

### 13.2.3. MAVLINK SETTINGS

MAVLink (Micro Air Vehicle Link) is used for communication between a Ground Station (GS) and unmanned vehicles, and in the inter-communication of the subsystem of the vehicle. It can be used to transmit the orientation of the vehicle, its GPS location, and speed.

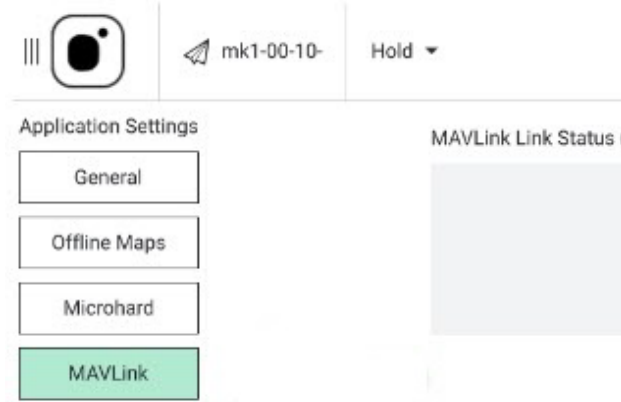

**Mavlink Link Status:** When the TAC is connected to a vehicle, this box displays link statistics consisting of the cumulative number of MAVLink messages sent, the number of messages received, the number of messages lost, and the loss rate expressed as a percentage.

When the TAC is not connected to a vehicle, there are no link statistics to display, and messages indicate that the TAC is not connected.

### 13.3. TEAL SETTINGS APP

The Teal Settings App is a new application introduced in the 1.6.0. software update. It will eventually replace the older Teal TAC Settings App. This new app handles toggling between the Wi-Fi and drone networks, toggling on and off new features such as Stealth Mode, pairing and maintaining a fleet.

### 13.4. TEAL TAC SETTINGS APP

Teal TAC Settings is the application software running in Android on the TAC for changing a few important TAC settings and functions. The Teal TAC Settings app manages which network that TAC is using, screen brightness, relaunch of Teal QGC when needed, and indicates the TAC's current software version.

Launch the app to open the Tac Settings screen.

### 13.5. TEAL DOCUMENTATION APP

Teal Documentation is the application software running in Android on the TAC that enables electronic viewing of Teal documentation. The user can access and view electronic versions of the system documentation, such as the Operator Manual, in the field right from the TAC, eliminating the need to carry a hard copy or another electronic device.

### 13.6. TEAL UPDATER APP

Teal Updater is the application software running in Android on the TAC. Teal Updater manages the details of the otherwise-complex software and firmware update process.

If an update is needed, the Teal Updater app will guide you through the process via an automated wizard.

#### 13.6.1. UPDATING SOFTWARE/FIRMWARE

System Requirements:

- Access to a wireless network with access to the internet.
- Ensure the system is paired and communicating.
- Use a fully charged battery pack in both the Teal 2 and TAC.
- Do not power off the vehicle or the TAC at any time during the update process.

Estimated Time: 15-25 Minutes

Follow along with our instructional video, *Firmware Updates: Teal 2 Drone*, on our website at: <https://tealdrones.com/support/training-videos/>. Or use the QR code:



1. Tap the **Teal Settings** icon to launch the app.
2. Tap **Configure Device** at the bottom of the screen.
3. Change the Active network from **Drone** to **WIFI**.
4. Login into the **WIFI** system with the appropriate login credentials.
5. Touch the **Teal Updater** icon to launch the app.

6. Select the **Check Cloud For New Version** button.
7. You will see the latest version available.
8. Select **Download From Cloud**.
9. You will see a **Download Complete** notification when finished.
10. You can now reconnect the Teal 2 and begin the installation process.
11. Connect to the Teal 2 by going back into the **Teal Settings** app and switching back from WIFI to **Drone**.
12. You will see a **Connected** message at the bottom of the screen of the **Teal Updater** app.
13. Select **Next** to update the Teal 2 and all its subsystems.

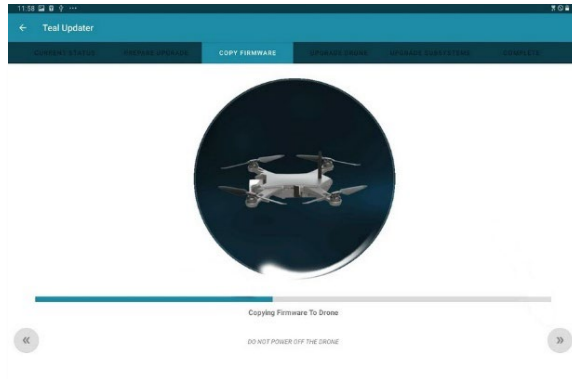

14. The system will first prepare the Teal 2. This should take less than a minute.
15. Select **Next** to continue.
16. The system will then copy the firmware on the TAC to the Teal 2. This may take 5 minutes or more.
17. Select **Next** to continue.
18. The system will then update all subsystems and will take about 5 minutes.
19. Select **Next** to continue.

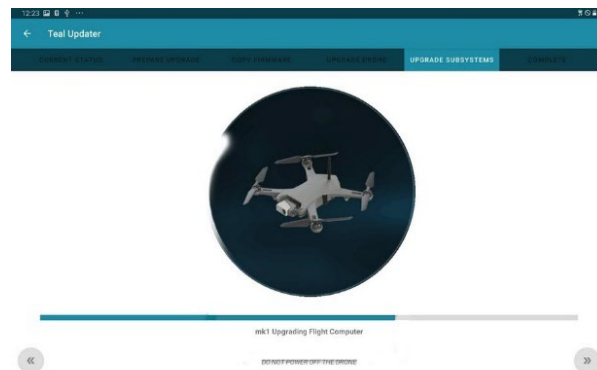

20. The system will then update all the ESCs, and chirping sounds and small movements from the Teal 2 are normal.
21. Once all subsystems are updated, you will see a confirmation screen.
22. Select **Next** to continue.
23. The system will then reboot the Teal 2. Once the reboot is complete, the update process is complete.
24. Select either the **Exit** button to return to the Teal QGC, or, select **Next** to go back to the beginning of the upgrade wizard to verify the new firmware version on the Teal 2.
25. Known errata: the firmware update process may take several reboot cycles to be successful. Please be sure to verify that the new firmware version is on the Teal 2.

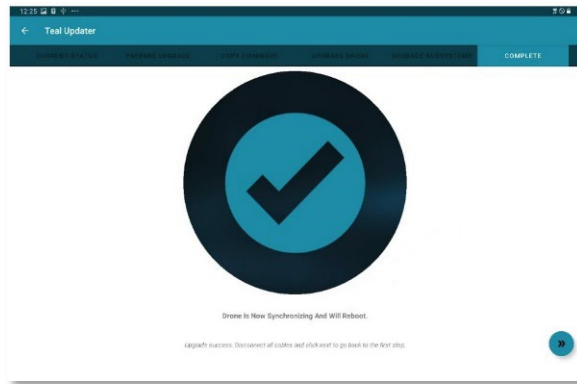

## 14. BATTERY PACK & CHARGER DETAILS

### 14.1. ARCHITECTURE & RATIONALE

Teal purposefully designed the power source for the Teal 2 and the TAC to use the exact same Teal Performance Battery Pack and Teal Battery Charger for both systems.

The battery charge level is visibly indicated by a 5-segment LED directly on the battery pack with a single tap of the power button. Batteries charge from 10% to 80% in 36 minutes and to 100% in 65 minutes.

When battery packs that have been exposed to low temperatures (32 °F (0 °C) or lower) for more than one hour, they must be pre-heated on the charger before flight.

Failure to pre-heat the battery pack before flight could reduce overall battery performance and affect overall flight time, up to 28%.

When the cold battery pack is placed on the charger, the 5-LED bar graph will indicate that the thermal blanket is activated by showing a green LED light pattern starting in the middle moving outwards. When this animation stops and the LED indicates the solid percentage of charge, it can be used for operations.

The amount of time this takes will vary upon the starting temperature of the battery pack.

The Teal Performance Battery Pack consists of six (6) Sony VTC6 18650 lithium-ion cells wired in series to produce a total nominal voltage of 22.2 volts (3.7 VDC per cell). The output voltage ranges from 21.6 VDC (3.6 VDC per cell) to a maximum of 25.2 VDC (4.2 VDC per cell). The cells have a capacity of 3 Ah (amp-hours), producing a total nominal energy of 66.6 Wh (watt-hours).

This results in approximately 60 usable Wh from the pack, which equates to flight time of up to 25 minutes for the Teal 2 and up to 8 hours of operation on the TAC.

#### CAUTION!



The Teal 2 and the TAC do not support a battery pack hot-swap. Be sure to power down the battery pack before removing and replacing it.

Per regulation, battery packs are shipped at not more than 30% state of charge and must be fully charged before using. The battery pack is configured by the factory to be in a very low power state called shipping mode in which only 15 uA is consumed. This results in a shelf life of several years.

When the user removes the battery pack from shipping mode, the lowest power state that the battery pack can enter is sleep mode. The battery pack will automatically go into sleep mode upon 72 hours of inactivity. The current consumption in this sleep mode is approximately 675 uA.

If a user removes the battery pack from shipping mode without further charging, the shelf life is 34 days from 30% to a 10% state of charge, and 52 days (7.4 weeks) to 0% state of charge. If a user removes the battery pack from shipping mode and fully charges the battery pack, the shelf life in sleep mode is 163 days (23 weeks) from 100% to a 10% state of charge, and 182 days (26 weeks) to 0% state of charge.

Pack dimensions are: 5.03” L x 2.86” W x 0.96” H (127.68 mm L x 72.67 mm W x 24.5 mm H).

Each pack weighs approximately 0.84 lbs (380 g).

Quickly push-and-release (tap) the button to briefly indicate the pack’s state-of-charge. Press-and-hold for four (4) seconds to power off and on. The middle LED in the charge level meter stays lit when the pack is powered on.







### 14.1.1. BATTERY LED INDICATORS

The battery pack has a 5-LED bar graph to indicate state-of-charge and power status indicated in 20% increments.



Current voltage can be found in the FLY TOOLS screen by touching the BATTERY icon.

This table summarizes user actions, the various resulting battery states, and LED indication of those states.

User Action	LED Action	Mode
Tap Power Button	 1 - 5 LEDs turn on, then off	Charge Level indication for 2 seconds
Tap Power Button	 2 <sup>nd</sup> & 4 <sup>th</sup> LEDs flash 3 times	In low-power <b>Shipping Mode!</b> Charge to exit!
Press & Hold for 4 seconds	 Sequential turn-on	Toggles battery Power to <b>ON</b>
Release after 4-sec hold	 Middle LED stays on	Battery Power is <b>ON</b>
Press & Hold for 4 seconds	 Sequential turn-off	Toggles battery Power to <b>OFF</b>
Release after 4-sec hold	 All LEDs off	Battery Power is <b>OFF</b>

## 14.2. TEAL BATTERY CHARGER

The Performance Battery Charger is a Teal-proprietary smart charger system built for charging Teal Performance Battery Packs. The charger converts the power supply's DC output and regulates its voltage and current output to optimally charge the battery.

The Smart Charge Adapter has an internal cooling fan that automatically turns on when power is applied to keep the smart charger electronics operating safely across the specified operating temperature range.

The battery pack is simply inserted onto the charger via mating slots in the battery pack, and the side latches on the battery pack securely lock it into place.

Charger dimensions are: 3.65" L x 3.52" W x 1.80" H (92.7 mm L x 89.4 mm W x 45.7 mm H). Each charger weighs 0.35 lbs (158 g).

## 14.3. CHARGER EXTERNAL POWER SUPPLY

The power supply for the Teal Battery Charger is an external cord-to-cord "brick" style switching power supply with a universal voltage input. It has a captive DC power cable and a removeable USA NEMA 5-15P to IEC 320 C13 AC power cable.

The power supply may be operated from AC voltages ranging from 100-240 VAC. The removeable AC cord can be replaced with an appropriate cord for that particular region.

The supply power unit is a fully sealed enclosure complying with IP32 environmental rating and operates in temperatures ranging from 32 °F to 140 °F (0 °C to 60 °C). It is approved to international medical and IT safety standards. The output power is 120 W, the output voltage is 25.2 V, and output current is 5.0 A ( $\pm 5\%$ ).

### CAUTION!



Always power down the Teal 2 and the TAC before removing and replacing their battery packs.



Charge within the limits of 32 °F to 113 °F (0 °C to 45 °C). Do not operate charger in direct sunlight to avoid exceeding temperature limits.



Remove the battery pack from the charger once it is fully charged to prevent unnecessary prolonged heating.



Unplug the charger power supply when not in use to prevent unnecessary heating and wear on electrical components.



Charge battery packs at least once every three months to prevent over-discharge and possible permanent damage.



Properly dispose of depleted or damaged battery packs in accordance with applicable federal, state, and local regulations.

## WARNING!



If improperly stored, lithium-ion batteries such as the Teal Performance Battery Pack may become unstable, overheat, damage cells, and potentially catch on fire.



Store batteries between -4 °F to 113 °F (-20 °C to 45 °C). Do not keep batteries in hot vehicles!



Store battery packs in an isolated area, away from flammable and combustible materials. If possible, store in metal storage cabinets.



Never stack heavy objects on top of boxes containing battery packs to prevent crushing or puncturing the cell case, leading to possible short circuits or fire.

# 15. MISCELLANEOUS

## 15.1. PACKAGING, SHIPPING & LABELING SPECIFICATIONS

### 15.1.1. PACKAGING & SHIPPING

All items are packaged in compliance with Department of Transportation (DOT) Pipeline and Hazardous Materials Safety Administration (PHMSA) and International Civil Aviation Organization (IATA) regulations for both ground and air transport. Batteries are shipped at not more than 30% state of charge. All required documentation is provided to the shipper.

Battery pack packaging and transport meet safety, environmental, mechanical, and electrical requirements for lithium cells detailed in section 38.3 of the UN Manual of Tests and Criteria (UN Transportation Testing) and the UN/DOT 38.3 to prevent short-circuiting, collapse by dropping or stacking, exposure to moisture and protection from damage by dropping.

### 15.1.2. LABELING

All packages are marked and labeled according to Department of Transportation (DOT) Pipeline and Hazardous Materials Safety Administration (PHMSA), and International Civil Aviation Organization (IATA) regulations for both ground and air transport. Packages that contain lithium batteries are clearly labeled with the UN3481 placard visible on the outside of the package, to include the overpack. Packages that only contain lithium batteries are clearly labeled with the UN3480 placard visible on the outside of the package.

## 15.2. PATENTS & TRADEMARKS

Teal is a wholly owned subsidiary of Red Cat.

The Teal GE/TAC system is manufactured under the following U.S. patents: 9,915,955; 9,926,077; 10,671,072; 10,683,089; 10,836,486.

All patents are held by UAV patent corp.

Teal Drones™, Teal 2™, and Teal Air Control™ are registered trademarks of Teal Drones, Inc.

### **15.3. ELECTRONIC VERSION**

An electronic version of this manual and all accompanying training videos can be found on our website at:

<https://tealdrones.com/support/>

or quickly access by scanning this QR code:





# 16. APPENDICES

18. APPENDIX A: TROUBLESHOOTING GUIDE

19. APPENDIX B: FIELD MAINTENANCE & SCHEDULE

# 17. TROUBLESHOOTING

This troubleshooting guide highlights the most commonly known issues and is not intended to be an exhaustive list. Contact Teal Drone Customer Support team at any time at (385) 281-8415 or at support@tealdrones.com.

ISSUE	SOLUTION
<p><b>CAMERA DOES NOT HOLD STEADY</b></p> <p>The camera payload on the Teal 2 “flops” and will not hold stable.</p>	<ol style="list-style-type: none"> <li>1. If in the air, wait 30 seconds. The gimbal will automatically try to stabilize itself.</li> <li>2. Restart the Teal 2 by powering it off and then on again.</li> <li>3. Make sure that there are no obstructions or debris in the gimbal payload.</li> </ol>
ISSUE	SOLUTION
<p><b>A BATTERY PACK SHUTS OFF AFTER AN ATTEMPT TO POWER ON</b></p>	
<p>A battery pack that is NOT connected to a Teal 2 or TAC immediately shuts off after an attempt to power it on.</p>	<p>This is normal behavior. The battery pack will remain powered on once connected to a Teal 2 or TAC.</p>
<p>A battery pack that is connected to a Teal 2 or TAC will not power on or immediately shuts off after an attempt to power it on.</p>	<ol style="list-style-type: none"> <li>1. Attempt to charge the battery pack:  <b>Tap</b> the power button once.  <b>Insert</b> the DC power cable into the charger and plug the AC power cord into an AC outlet.  <b>Insert</b> the battery pack onto the charger.  <b>Verify</b> that the green LEDs on the battery pack are illuminated to indicate the battery pack is charging.</li> <li>2. If the attempt to charge is unsuccessful, please contact Teal Drone Customer Support:            (385) 281-8415            support@tealdrones.com</li> </ol>
ISSUE	SOLUTION
<p><b>THE TEAL 2 WILL NOT ARM</b></p> <p>The Teal 2 will not arm using either the arm button or soft key commands.</p>	<ol style="list-style-type: none"> <li>1. Make sure that the battery pack is powered on and is fully charged. The Teal 2 will not arm when the battery pack charge level is 20% or less.</li> <li>2. If in Position Flight Mode, you may not be connected to a sufficient number of satellites to be able to triangulate the position of the vehicle. It is critical to have at least eight (8)</li> </ol>

	but recommended that ten (10) satellites are indicated on the GPS icon prior to takeoff.
--	--

ISSUE	SOLUTION
<p data-bbox="134 178 808 220"><b>BUTTONS/JOYSTICKS DO NOT RESPOND</b></p> <p data-bbox="134 224 808 294">The buttons or joysticks on the TAC are not responding and are not commanding the Teal 2.</p>	<ol data-bbox="868 178 1429 441" style="list-style-type: none"> <li>1. Perform the joystick setup once more:</li> <li>2. Connect the vehicle and TAC.</li> <li>3. Touch the <b>Main menu</b> icon.</li> <li>4. Select <b>Vehicle Setup</b>.</li> <li>5. Select <b>Joystick</b>.</li> <li>6. Use the <b>General, Button Assignment, and Advanced</b> windows to customize the joystick and buttons as desired.</li> </ol> <p data-bbox="820 472 1380 588">Contact Teal Drone Customer Support: (385) 281-8415 support@tealdrones.com</p>
ISSUE	SOLUTION
<div data-bbox="134 865 251 945">  </div> <p data-bbox="267 865 808 934"><b>AN ERROR SYMBOL APPEARS WHEN ATTEMPTING TO SNAP A PHOTO</b></p> <p data-bbox="134 955 808 1060">When attempting to snap a photo, an error symbol appears indicating that the attempt was unsuccessful.</p>	<p data-bbox="820 865 1380 934">Make sure that the photo functions in the <b>General Settings</b> are enabled:</p> <ol data-bbox="868 945 1445 1176" style="list-style-type: none"> <li>1. Touch the <b>Main menu</b> icon.</li> <li>2. Select <b>Settings</b> at the bottom of the screen.</li> <li>3. Select <b>General</b>.</li> <li>4. Scroll down to <b>Picture Settings</b>.</li> <li>5. Check the <b>Download Full Res Image In Flight</b> box.</li> </ol>

ISSUE	SOLUTION
<p><b>UNCOMMANDED FLIGHT IN A CIRCULAR MOTION aka “TOILET BOWLING”</b></p>	<ol style="list-style-type: none"> <li>1. Try to fly a figure-8 pattern in the air to regain control.</li> <li>2. Land and perform a compass/ magnetometer calibration:</li> <li>3. Connect the vehicle and TAC.</li> <li>4. Touch the <b>Main menu</b> icon.</li> <li>5. Select <b>Vehicle Setup</b>.</li> <li>6. Select <b>Sensors</b>.</li> <li>7. Select <b>Compass</b> to calibrate the magnetometer.</li> <li>8. Be ready to pick up and rotate the Teal 2.</li> <li>9. Click OK in the top right of the screen to begin.</li> <li>10. The first tone from the Teal 2 will alert you to begin. Follow the instructions on the TAC screen.</li> <li>11. The second tone will prompt you to hold the Teal 2 steady for the next orientation.</li> <li>12. Select <b>Reboot Vehicle</b> when finished.</li> <li>13. Reestablish connection between the TAC and the Teal 2.</li> </ol> <p> Due to known errata, it is recommended to perform a power cycle (turn the Teal 2 battery pack off and on again).</p> <p>Contact Teal Drone Customer Support:  (385) 281-8415  support@tealdrones.com</p>
<p>The Teal 2 will be stuck flying in a circular motion uncommanded.</p>	

ISSUE	SOLUTION
<p><b>THE COMPASS INDICATOR SPINS/DOES NOT HOLD STEADY</b></p>	
<p>The compass or heading indicator on the TAC fly view will spin or drift instead of holding steady.</p>	<ol style="list-style-type: none"> <li>1. Perform a compass/magnetometer calibration:</li> <li>2. Connect the vehicle and TAC.</li> <li>3. Touch the <b>Main menu</b> icon.</li> <li>4. Select <b>Vehicle Setup</b>.</li> <li>5. Select <b>Sensors</b>.</li> <li>6. Select <b>Compass</b> to calibrate the magnetometer.</li> <li>7. Be ready to pick up and rotate the Teal 2.</li> <li>8. Click OK in the top right of the screen to begin.</li> <li>9. The first tone from the Teal 2 will alert you to begin. Follow the instructions on the TAC screen.</li> <li>10. The second tone will prompt you to hold the Teal 2 steady for the next orientation.</li> <li>11. Select <b>Reboot Vehicle</b> when finished.</li> <li>12. Establish connection between the TAC and the Teal 2.</li> </ol> <p> Due to known errata, it is recommended to perform a power cycle (turn the Teal 2 battery pack off and on again).</p>

ISSUE	SOLUTION
<b>MAPS DO NOT CACHE/SAVE</b>	<ol style="list-style-type: none"> <li>1. Make sure that the active network has WIFI selected.</li> <li>2. Make sure that proper procedure was followed in the <b>Offline Maps</b> screen:</li> <li>3. Touch the <b>Teal Tac Settings</b> icon.</li> <li>4. Change the <b>Active network</b> from Drone to WIFI.</li> <li>5. Login into the WIFI system with the appropriate login credentials.</li> <li>6. Slide the <b>Settings</b> screen all the way to the right to open the QGC app.</li> <li>7. Touch the <b>Main menu icon</b> in the top left of the screen.</li> <li>8. Select <b>Settings</b> at the bottom left of the screen.</li> <li>9. Select Offline Maps.</li> <li>10. Select <b>Add New Set</b>.</li> <li>11. Set and zoom to the area that you would like to save.</li> <li>12. Create a name for map set in the <b>Add New Set</b> field.</li> <li>13. Set the map type.</li> <li>14. Check the <b>Fetch Elevation Data</b> box to include elevation data with the tile set.</li> <li>15. Select <b>Download</b> when finished.</li> <li>16. Touch the <b>Main menu icon</b> in the top left of the screen.</li> <li>17. Select the <b>Fly</b> button.</li> <li>18. Touch the <b>Teal TAC Settings</b> icon.</li> <li>19. Change the Active network to <b>Drone</b> from WIFI.</li> <li>20. Once the TAC acquires the GPS signal, the map screen will automatically load that tile set.</li> </ol>
Maps are not saved or imported on the TAC.	

# 18. FIELD MAINTENANCE & SCHEDULE

## 18.1. FIELD REPLACEABLE PARTS

Field replaceable parts are easily replaced in the field. Use the tools provided in the Field Spares Kit to replace and repair parts.

This manual does not cover repairs, upgrades, or software updates that cannot be performed in the field. Attempting repairs, upgrades, or software updates not covered in this manual may void conditions and terms of the warranty.

## 18.2. MAINTENANCE SCHEDULE

### 18.2.1. AFTER 10 FLIGHT HOURS OR AS NEEDED

1. Clear and format the SD Card media.
2. Clean all sensors and the vehicle with a damp cloth and a can of air.
3. Fully discharge all batteries and charge back to full capacity.
4. Verify the gimbal and camera connectors are securely seated.
5. Update the Teal 2 and the TAC software.
6. Delete and re-download offline maps to get latest versions.
7. Clear flight logs from the Teal 2.

### 18.2.2. AFTER FLIGHT MAINTENANCE OR AS NEEDED

1. Replace propellers every 10 hours of flight.
2. Replace arms.
3. Retire battery pack after 150 charge/discharge cycles.

## 18.3. ROTOR ARM REPLACEMENT

Replace the entire arm when the rotor arms are damaged or worn. The spare arms are prewired with the motor installed and only need to be locked into place and secured with a single Torx T8 screw per arm. The Torx T8 screwdriver is included in the Field Repair Kit. Use the included Torx T8 screwdriver to replace the arms.

Arms are keyed as clockwise (CW) and counter clockwise (CCW) on the airframe. The CW and CCW arms are not interchangeable.

### 18.3.1. ARM REPLACEMENT INSTRUCTIONS

1. Place the Teal 2 on its back on a table or workspace. Hang the antenna off the edge of the table to prevent damage.



2. Remove the single T8 Torx screw on the motor arm with the T8 Torx screwdriver.
3. Set the screw aside for re-use.
4. Pull the arm straight out of the socket.
5. Insert the new arm into the airframe. Push firmly until the screw holes on the arm and frame align.
6. Use the Torx T8 screwdriver to tighten the screw and secure the arm into place.
7. Test the motor to ensure it functions properly for the next flight.



## 18.4. CAMERA AND GIMBAL PAYLOAD REPLACEMENT

Both the FLIR Hadron EO/IR camera and gimbal are replaceable in the field. Use the specific tools to prevent damaging parts in the repair process.

### 18.4.1. CAMERA & GIMBAL REPLACEMENT INSTRUCTIONS

1. Place the Teal 2 on its back on a table or workspace. Hang the antenna off the edge of the table to prevent damage.
2. Remove the four rubber grommets on the gimbal brackets. Use a screwdriver to push the grommets through the hole.



3. Use your fingernail or a screwdriver to press the tab on the motor cable connector.



4. Pull the connector straight up to disconnect it from the socket.
5. Pull the connector straight up to disconnect it from the socket.
6. Squeeze the side latches of the camera data cable connector to release it.
7. Pull the connector straight up to disconnect it from the socket.
8. Use a T5 Torx screwdriver to remove the four M1.6 x 0.35mm screws from the back of the Hadron camera. Set the screws aside for re-use.
9. Pull the Hadron camera away from the gimbal.

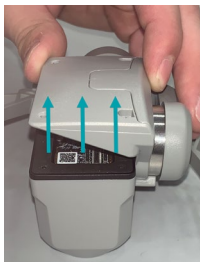

10. Check the gasket around the PCB on the Hadron camera is properly aligned. Adjust if needed.
11. Push the Hadron camera onto the gimbal. Press straight down until you feel the connector click into place.
12. Use a T5 Torx screwdriver to secure the four M1.6 x 0.35 mm screws in the back of the Hadron camera.
13. Connect the camera data cable connector to the mating socket in the Teal 2. The side of the cable is facing toward the front of the Teal 2.
14. Connect the gimbal motor cable connector to the mating socket in the Teal 2. The tab on the connector faces the front of the Teal 2.

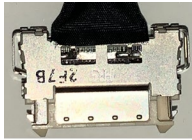

This side of the camera data connector faces the Hadron Camera.

15. Align the rubber grommets on the gimbal under the holes on the gimbal brackets.



16. Pinch and pull the rubber grommets through the bracket holes.



#### **CAUTION!**



The exposed PCB is ESD sensitive and static discharge can damage the electronics. Minimize handling of the exposed PCB.

### **18.4.2. SYSTEM CHECKOUT**

1. Manually move the gimbal pitch and roll axis and check for binding or obstructions.
2. Check that no wires are pinched.
3. Power on the system and confirm the gimbal properly functions and is properly oriented.

### **18.5. PROPELLER REPLACEMENT**

Individually damaged or worn propeller blades require the entire propeller to be replaced. They are easily installed, removed, or replaced with a simple push-and-twist method that requires no tools or hardware.

There are two CW propellers and two CCW propellers. The propellers are keyed so that the CW and CCW props cannot be mounted to the wrong hub.

The CW propellers have black rivets that secure their blades. The CW propellers lock into place by turning them in a CCW direction.

The CW propeller motors have a black ring below the spring. The CW propeller motors have a black ring below the spring. The CCW propellers lock into place by turning them in a CW direction.

The two CCW propellers have silver rivets that secure their blades. The two CCW propeller motors have a silver ring below the spring. The CCW propellers lock into place by turning them in a clockwise direction.



### 18.5.1. PROPELLER REPLACEMENT INSTRUCTIONS

1. To remove a propeller, push down and rotate until the propeller comes free.
2. To attach a propeller to a motor, line up and insert the three bent legs on the underside of the propeller into the three slots on the motor.

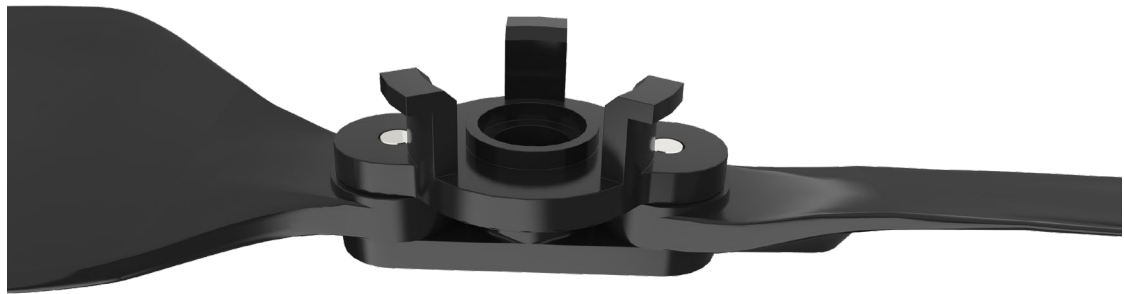

3. Hold the propeller motor in place while pushing down to compress the spring on the shaft. Rotate the propeller into place. Allow the spring to push the hub up into its locked position.