

Declaration of Design Specification

Die Firma:
the company of:

Quantum-Systems GmbH
Dornierstr. 11
82205 Gilching

declares, that the Battery Pack of the UAV Trinity F90+ complies with the IATA Air Transport regulations for dangerous goods, as valid for Lithium Battery Packs.

The Battery of the Trinity consists out of 4 physically separated battery packs, each containing 64,8 Wh. This is below the allowable 100 Wh. The logics of the physical separation of the battery packs is visualized in the following wiring diagram. The packs become physically connected via the plugs counter part on the UAV side.

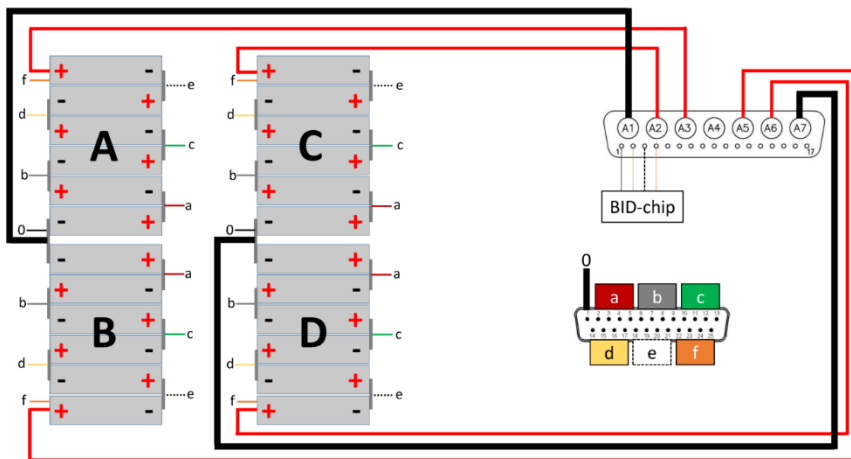

Type: Trinity F90+ Battery Pack

Serial number: Ongoing Number

This declaration is issued by, acting for and on behalf of
Quantum-Systems GmbH • Dornierstr. 11 • 82205, Gilching, Germany

Tim Ganzer/Certification Manager
Name / Function

Gilching, December 13th, 2021

