

DeltaQuad Evo GOV operations manual

DeltaQuad Evo Government Edition

The DeltaQuad Evo Government Edition VTOL UAV is a state-of-the-art unmanned aerial vehicle designed for government applications.

Version number of this document: v2.1-beta-15.03.2024



It features cutting-edge technology and advanced features that make it ideal for a range of missions, including reconnaissance, surveillance, and target acquisition. The following product sheet provides a comprehensive overview of the various configurations available.

The Evo Government edition has been specifically designed for governmental agencies. The product is intended for deployment in environments where interference with radio or satellite navigation is not anticipated. Its key features include an S-BAND radio system with up to 80 km range, Toughbook ground control, and ATAK compatibility, which enhance the effectiveness of government operations.

Introduction



This document describes how to set up, operate, and maintain your DeltaQuad Evo series VTOL UAV.

Document status: DRAFT

Safety and legal notice

- The vehicle must be operated in accordance with local laws and regulations.
- The vehicle may not be operated or flown near or over people, roads, vehicles, buildings, or anything that could result in damage or danger to people or property.
- Radio or video transmitters might require special licensing and/or permits.
- DeltaQuad or its affiliates can not be held responsible for vehicles that have not been operated or maintained in accordance with the guidelines set forth in this manual, or for behavior resulting from changes made to the vehicle.
- This operations manual is provided "As-Is". No rights can be obtained from the contents of this manual.
- The original language of this document is English, if this document is read in a translation to any other language, the interpretation of the English version takes precedence.
- Software used in conjunction with the vehicle is provided under their respective license and warranty.
- The vehicle is provided in accordance with the DeltaQuad [Warranty](#) and under the DeltaQuad [Terms & Conditions](#).
- The DeltaQuad Evo is not a toy and is not suitable for people under the age of 16.

Vehicle specifications

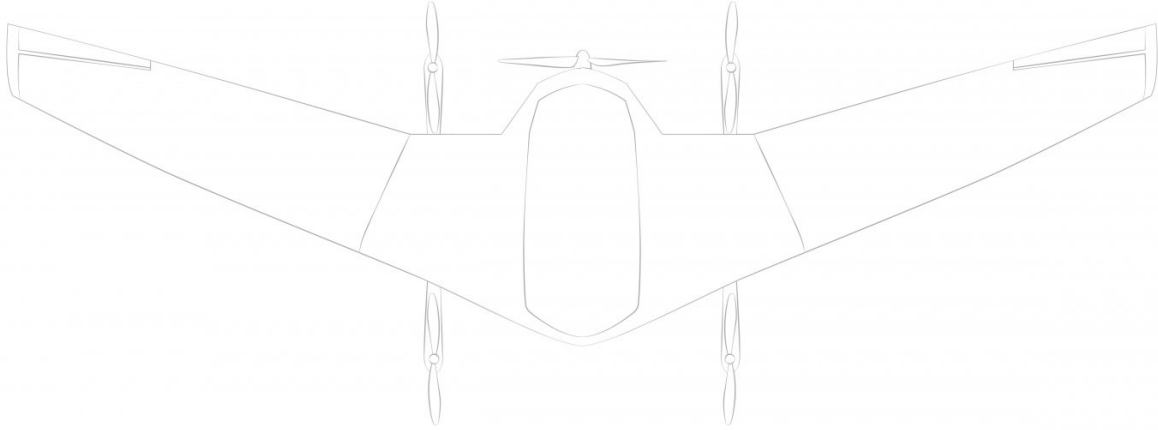

i To calculate the expected performance of the DeltaQuad Evo based on specific payloads and conditions, please refer to the [DeltaQuad Evo Performance Calculator](#).

Dimensions:	
Wingspan	269 cm
Length	75 cm
Height	33 cm (landing gear extended)
Wing area	84 sq. dm.
Payload bay	20 x 20 x 11 cm
Flightcase dimensions	112 x 82 x 46 cm
Flightcase weight	~ 30.4 kg
Weight and Payload:	
Empty weight	4.8 kg
Empty weight including 1 battery	6.8 kg
Maximum takeoff weight	10 kg
Payload capacity	3 kg
Flight Characteristics with Dual battery:	
Flight speed	16.61 m/s (60 km/h)
Payload capacity	1 kg
Maximum flight time	255 minutes (4 hours 15 minutes)
Range through air	254 km (158 mi)
Power	
Battery type	Semi Solid State Lithium-ion
Battery cells	6
Battery capacity	22Ah per battery
Tolerances *	
Maximum takeoff/landing wind	12.5 m/s (45 Km/h)

Maximum wind cruise flight	14 m/s (50 Km/h)
Maximum precipitation	7mm/h (Drizzle)
Operating temperature	Between -20 and +45 Celsius
Maximum flight altitude AMSL	13.000ft (4000m)

All flight characteristics are based on optimized settings at sea level

These values assume 90% battery usage, and low wind conditions and include a low-altitude vertical takeoff and landing at sea level.

* The tolerances are provisional and subject to change

Setup

This chapter covers the basics of the DeltaQuad Evo.

Chapter index

- [DeltaQuad Evo flight case](#)
- [Assembly](#)
- [Replacing the propellers](#)
- [DeltaQuad Evo battery](#)
- [Safety features](#)

DeltaQuad Evo flight case

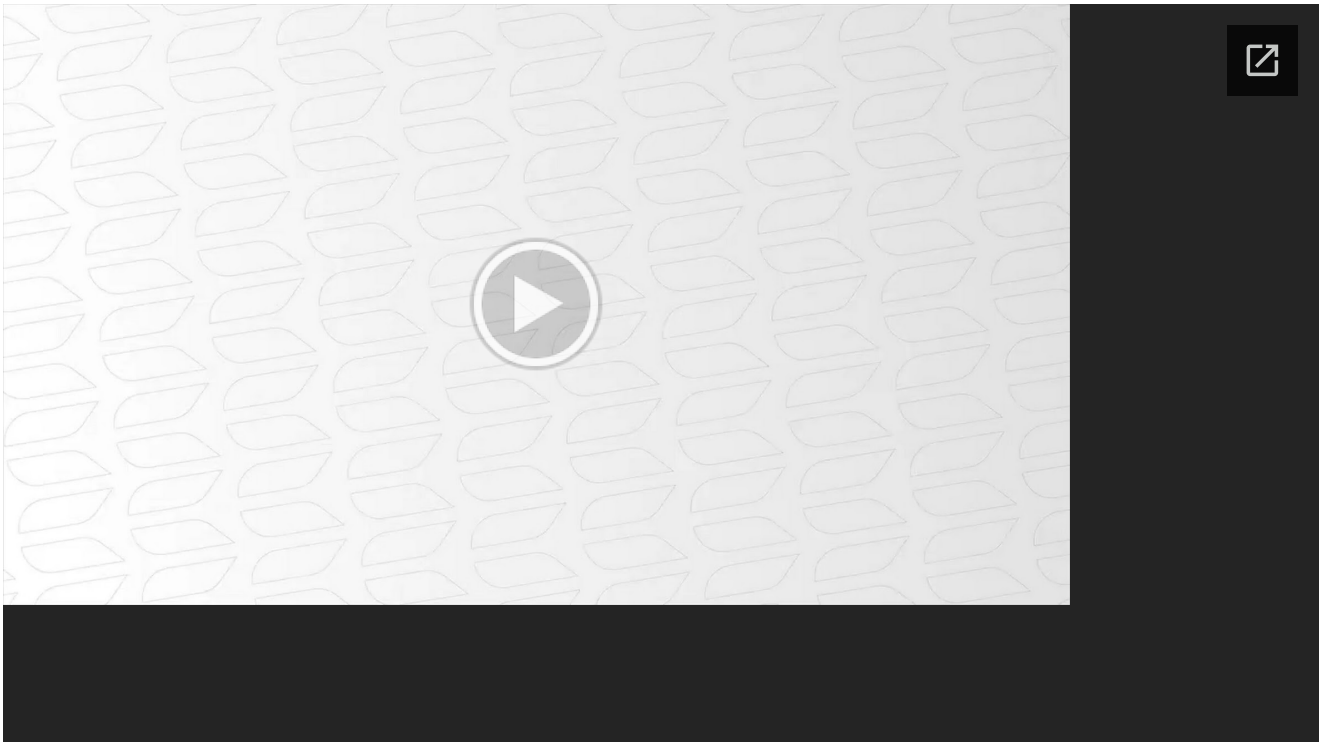

The DeltaQuad Evo and its accessories are stored in a rugged flight case.



Package contents

- 1 x Fuselage
- 2 x Wing
- 4 x DeltaQuad Evo Semi Solid-State Li-ion battery
- DeltaQuad Dual Battery Charger
- 1x auxiliary battery payload box
- 1x empty payload box
- Ground Control Station (Controller or ruggedized laptop) and accessories
- Optional payloads

When removing the fuselage from the flight case you gain access to five extra compartments



Nr.	Compartment
1	Controller* and accessories
2	Battery compartment
3	Payload compartment
4	Dual Charger compartment
5	Ruggedized laptop*

 **Depending on the Evo version, the Ground Control Station can be either a hand controller or a ruggedized laptop. The functionality and use of this equipment will be discussed in a later chapter of this manual.*

Assembly

In this section, we cover the steps for assembling and disassembling the DeltaQuad Evo.

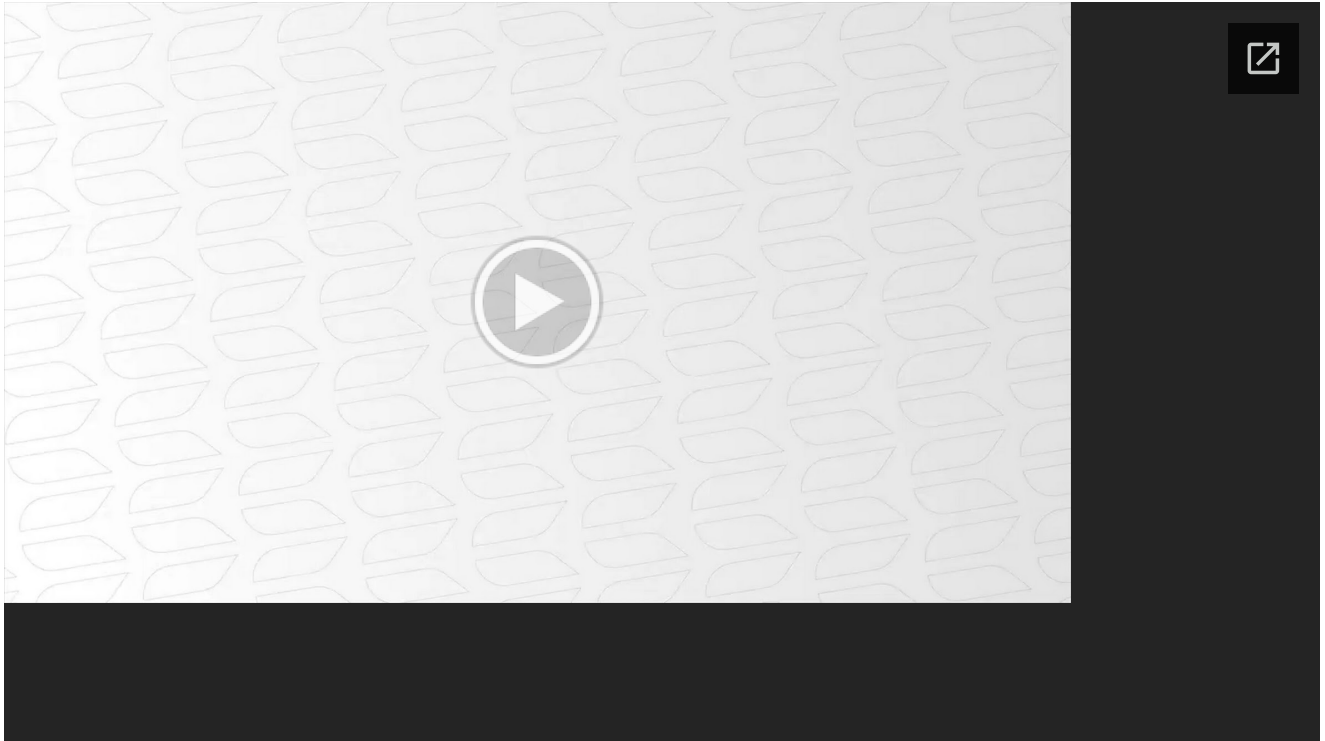

Assembly and disassembly of the DeltaQuad Evo

Unpacking and initial hardware setup

For the initial hardware setup, make sure you have ample room to work. Carefully unpack all components from the flight case and inspect them for any damage. If there is damage to your vehicle please document and report this damage to DeltaQuad.

Mounting the wings

Take the DeltaQuad Evo out of the flight case and place it on a flat surface with the landing gear deployed.



The wing has a big spar close to the leading edge and a smaller spar close to the trailing edge. In front of the big spar is a keying mechanism located in the form of a cuboid.

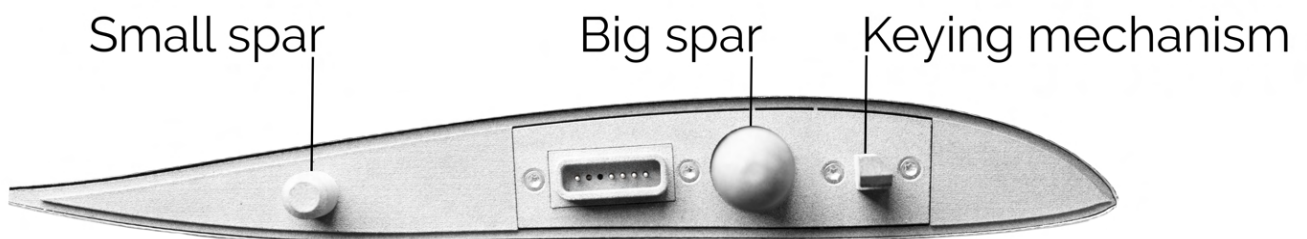

This keying mechanism prevents mounting the wings on the wrong side.

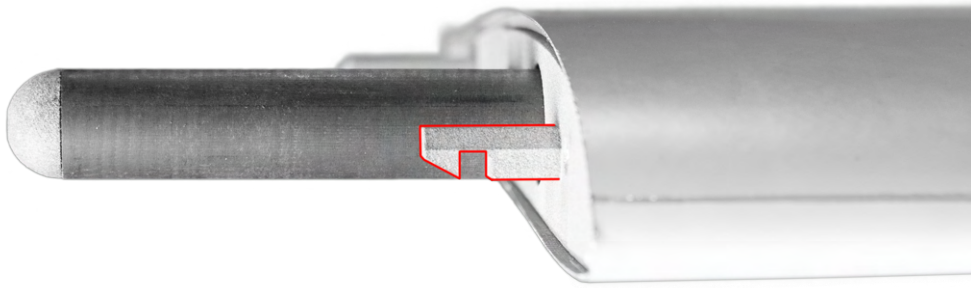

- i** The wings of the DeltaQuad Evo must be mounted in such a way that the wingtips point downwards.



Slide the carbon spars of the wings into the corresponding blind holes of the fuselage.



When fully locked a clicking sound from the wing lock mechanism must be audible and the wing lock must sit flush with the fuselage.



- i** The wing is not properly installed if the wing lock doesn't make a click sound or doesn't sit flush with the fuselage.

Disassembly and storage

To disassemble the DeltaQuad Evo, follow the steps for the assembly in reverse order.

Press down the wing lock mechanism with the thumb while the same hand is holding the fuselage in place. With the other hand pull the wing away from the fuselage.

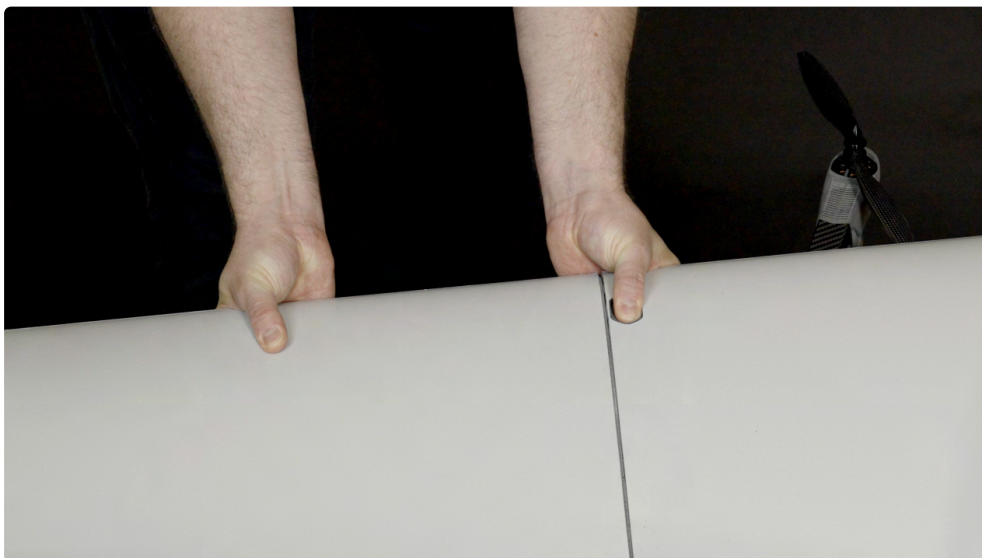

⚠ When storing the fuselage inside the flight case, the landing gear must be deployed.

ℹ It is recommended to transport the DeltaQuad Evo in the flight case.

Replacing the propellers

The DeltaQuad Evo comes with 5 propellers, 1 composite "pusher" propeller, and 4 carbon fiber VTOL propellers. The propellers should already be attached when you receive the vehicle. When replacing the propellers please follow these guidelines.

The VTOL propellers consist of 2 Clock Wise (CW) propellers and 2 Counter Clock Wise (CCW).

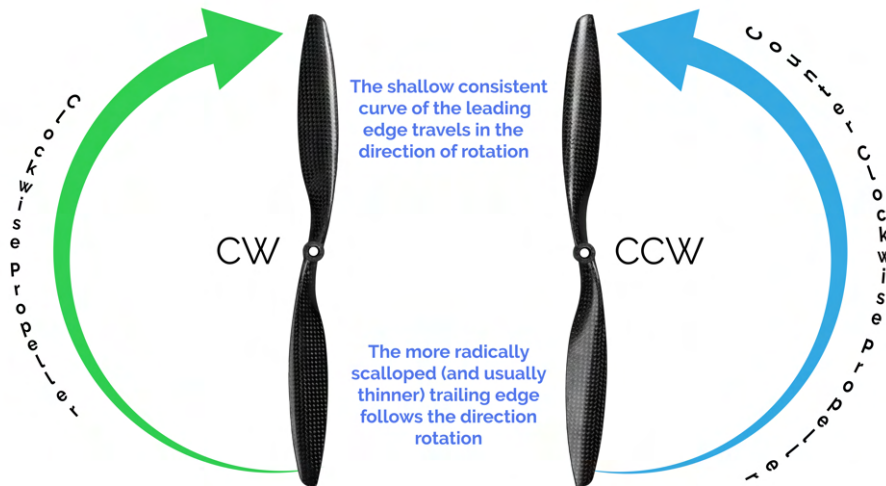

The bullet-type nut on the propeller adapters is self-tightening, which means they close by turning them in the **opposite direction** of how the motor/propeller spins. This is done to ensure the propellers do not become detached when the motor spins up. This means that to undo the nut on motors 1 and 2 it turns left, and on motors 3 and 4, it turns right.

The propellers are centered with a small ring inside the mounting hole, this should result in the propeller sitting tightly around the shaft.



Always ensure the centering ring is present and the propeller fits tightly around the shaft.

Mount the propellers in the following positions noting the direction of the propeller as indicated below:



The propellers are attached by removing the motor nut and washer, sliding the propeller on the shaft, sliding the washer on top of the propeller, and fastening the nut.

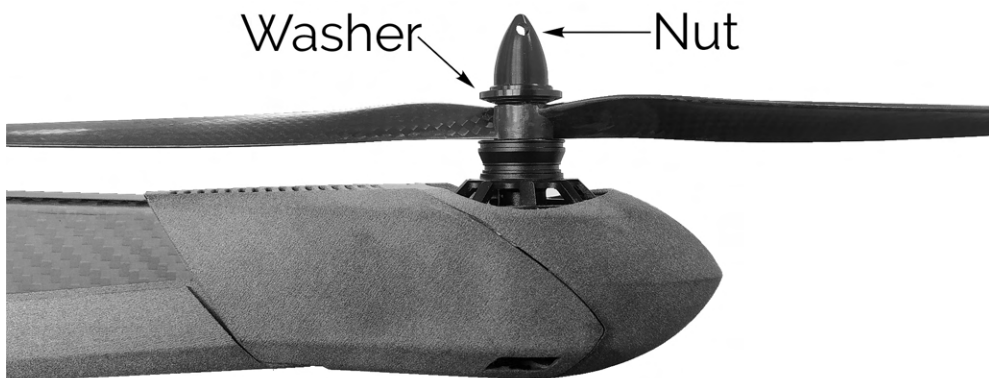

For the vertical motors (VTOL motors), please make sure to install the washer in the right orientation. The washer has a wider side on top.



Replacing the pusher propeller

The DeltaQuad Evo pusher propeller is an APC 15x10E propeller that contains a modified ring to mount properly on the DeltaQuad Evo pusher motor. Please only use DeltaQuad-approved and balanced pusher propellers.

The pusher propeller should be mounted so that the propeller produces thrust towards the rear, this means that the top of the propeller (the side that has the text engraved) should face the motor as shown in the diagram below.

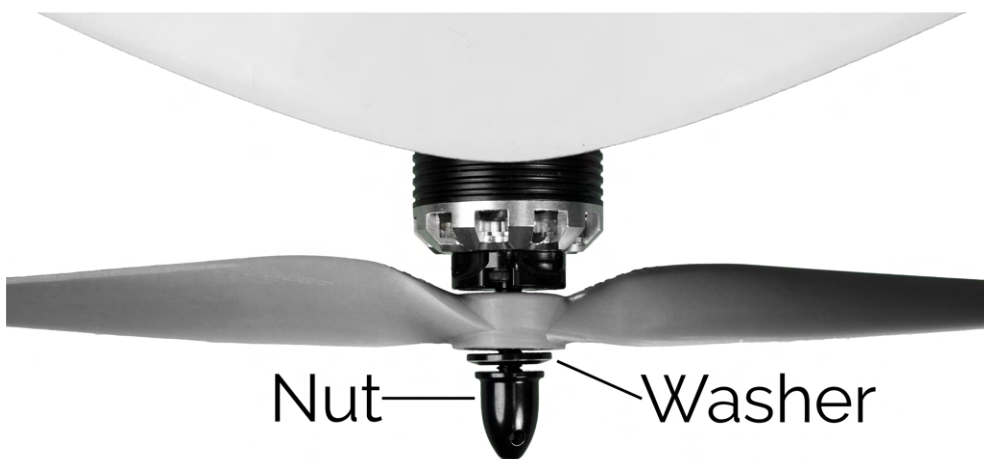

Text towards motor

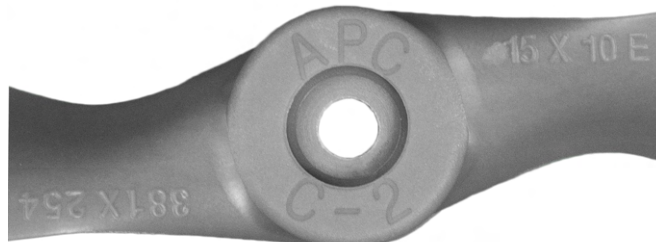

i *Note: All propellers are balanced in our factory by hand. This can leave scratch marks on the propeller blades. This does not indicate damage or that the propellers are used. A sign of damage can be structural weakness such as a bent propeller blade. If you find gouges or missing parts anywhere at the tip, the outboard region, or the trailing edge of the blade you need to replace the propeller.*

DeltaQuad Evo battery

In this chapter, we will discuss the DeltaQuad Semi Solid-State Li-ion battery, how to handle it, how to place it inside the DeltaQuad Evo, and how to power up the vehicle.

- [Battery handling](#)
- [Charging and storing the battery](#)
- [Battery placement](#)
- [Auxiliary battery placement](#)
- [Powering the vehicle](#)

Battery handling

This chapter will discuss how to properly handle the DeltaQuad Semi Solid-State Li-ion battery.

The DeltaQuad Evo is compatible with the DeltaQuad Semi Solid-State Li-ion battery. Using other batteries is not recommended and will impact your warranty.



Safety notice

- Use only the DeltaQuad Dual Battery Charger. Do not use a NiCd or NiMH charger - Failure to do so may cause a fire, which may result in personal injury and property damage.



- Never charge batteries unattended unless you charge inside a Battery Safe. When charging LI-ion batteries you should always remain in constant observation to monitor the charging process and react to potential problems that may occur.
- If at any time you witness a battery starting to balloon or swell up, discontinue the charging process immediately. Disconnect the battery and dispose of it safely. Continuing to charge a battery that has begun to swell will result in fire. Likewise, never use a battery if you find it swollen or ballooned.
- Since a delayed chemical reaction can occur, it is best to observe the battery as a safety precaution. Battery observation should occur in a safe area outside of any building or vehicle and away from any combustible material.
- Wire lead shorts can cause a fire! If you accidentally short the wires, the battery must be placed in a safe area for observation for approximately 1 hour. Additionally, if a short occurs and contact is made with metal (such as rings on your hand), severe injuries may occur due to the conductivity of electric current.
- A battery can still ignite even after 1 hour.
- A battery that makes a hissing sound is almost certain to ignite. Consider your own safety and that of your environment before attempting any action
- In the event of a crash, after a 15-minute period to ensure the battery was not compromised, you must remove the battery and dispose of it safely.

 Only place the battery before the flight, and remove the battery directly after the flight. Always transport the battery in the dedicated compartment of the flight case or in a safe transportation unit such as a fireproof bag or storage container.

Charging and storing the battery

This chapter will discuss how to charge and store the DeltaQuad Semi Solid-State Li-ion battery properly.

Charging the battery

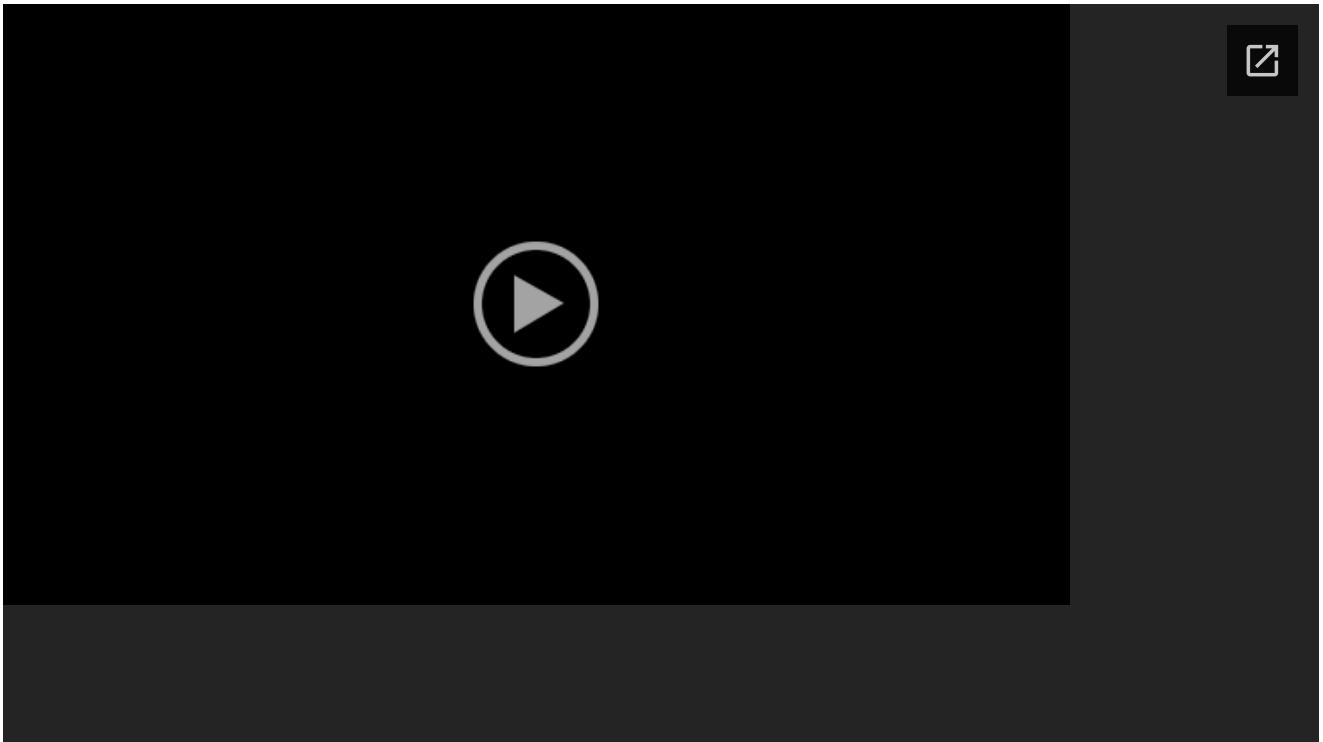

i The DeltaQuad Evo Li-ion battery is capable of charging within 1 hour at 20 Amperes. Charging at this rate will limit the durability of the battery. It is recommended to charge the battery at no more than 15 Amperes for a maximum lifetime.

- Power on the DeltaQuad Dual Charger.
- Plug the yellow XT90 connector from the power cables of the battery into the charger.

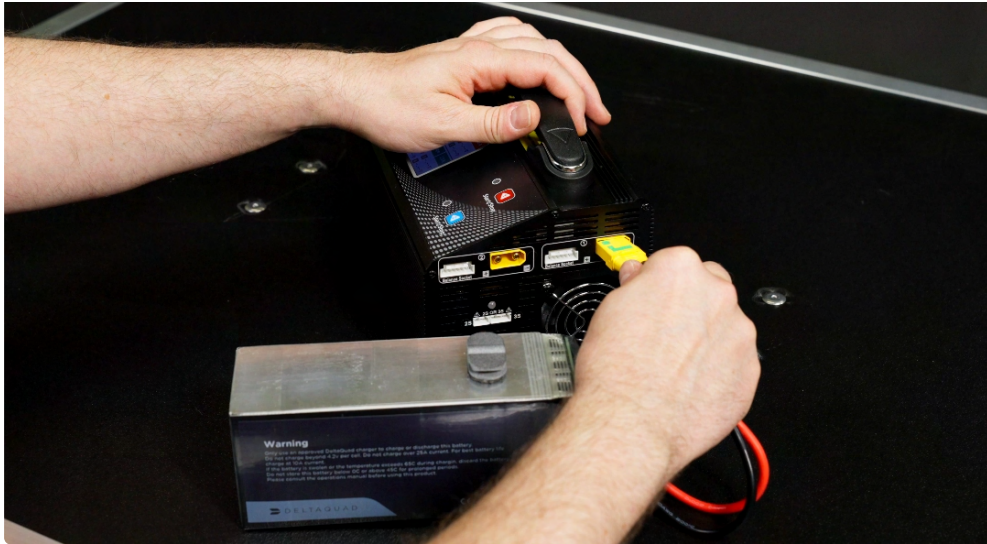

- Take the balance lead which is the smaller group of cables with the white connector and plug it into the respective balance port of the charger.



- With the DeltaQuad dual charger, you can charge two batteries simultaneously. Therefore make sure to connect the cables of one battery to the same channel.

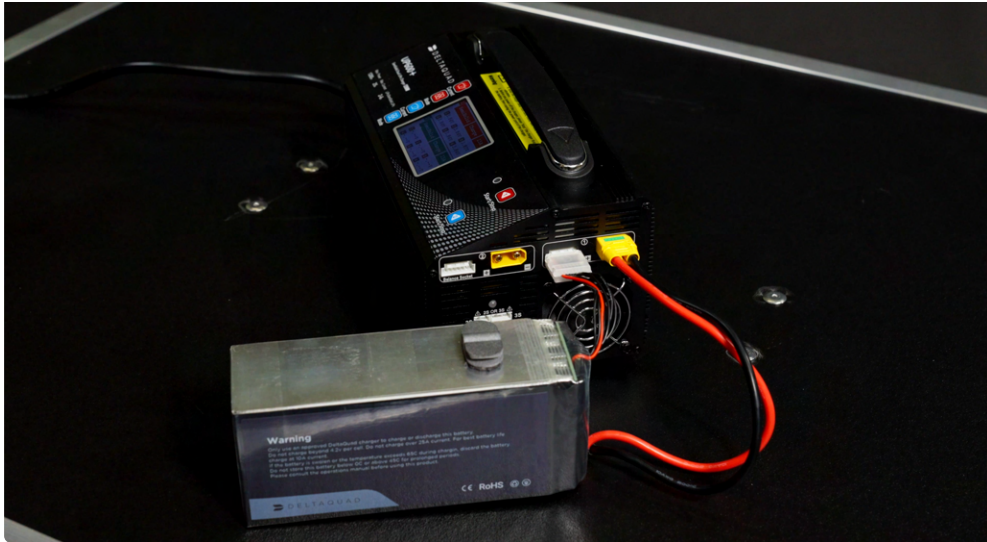

- Per channel, you have two buttons. One for the current and one for the mode.

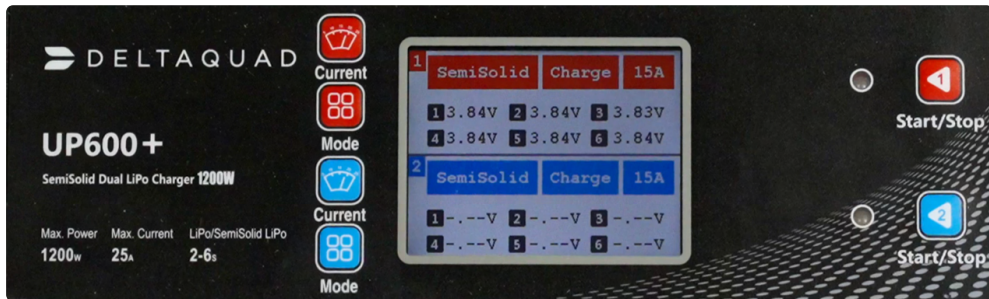

- Set the mode to "Charge" by pressing the mode button.

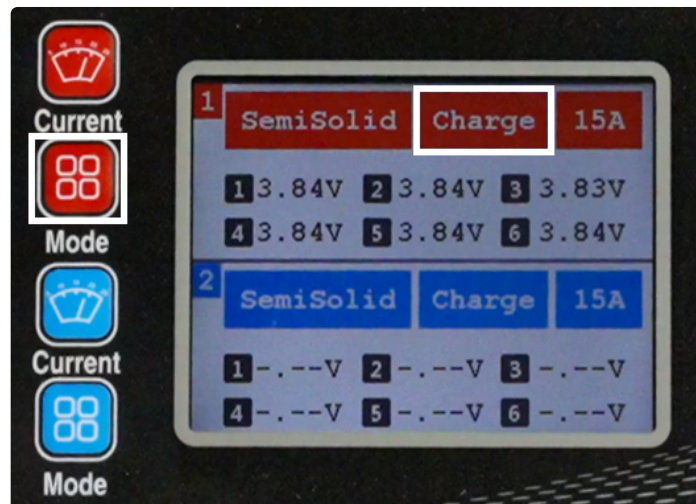

- We recommend charging the DeltaQuad Evo batteries at 15 amperes. You can cycle through the available values by pressing the current button.

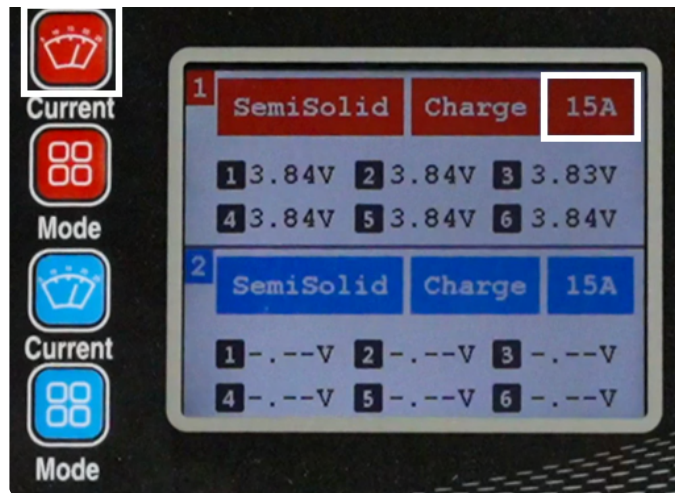

- Press start.



- Your DeltaQuad Evo battery is now charging.

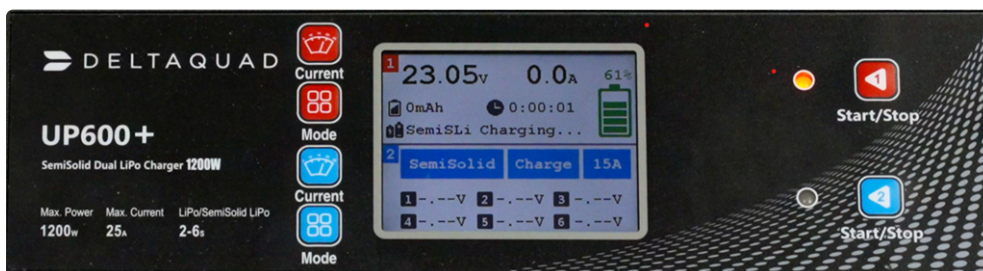

Storage charge the battery

- i When not using the battery for a longer period of time it is recommended to storage charge the battery with the provided DeltaQuad Dual Battery Charger. By doing so the battery will be either charged or discharged to 3.7V per cell which equals 50% battery capacity.

- Plug in the power and balance cable of the battery to one of the channels of the charger.
- Set the mode to "Storage" by using the mode button.

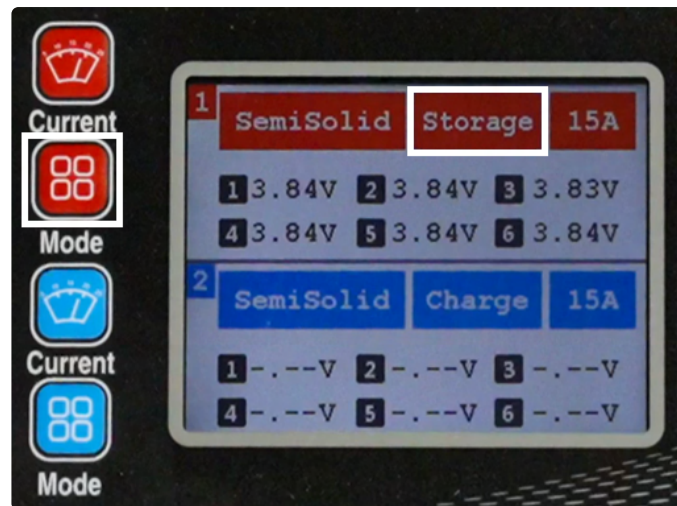

- Press "Start".
- If the battery is fully charged when using the storage mode, the charger will discharge the battery to 50% of its capacity. This process can take longer as the discharge power per channel is only 40W.
- If the battery is below 50% capacity when using the storage mode, the battery will be charged to 50% capacity at the set current value.

Storing the battery

The battery should be stored in a safe and dark location between 5 and 30 degrees Celsius. If the battery has been fully discharged, putting at least some charge (+- 50%) before long-term storage is recommended. This can be done by using the storage mode of the dual charger.

Battery placement

This chapter will discuss the proper placement of the main and the auxiliary battery.

Placing the main battery

The DeltaQuad Evo has a battery bay (blue), a payload bay (green), and an avionics bay (red).



The main battery needs to be placed on the tray in the battery bay which is located at the front of the fuselage.



The tray has the same form and shape as the underside of the battery.



The battery must be placed in such a way that it fits on the tray.



The thicker power cables must exit the bottom of the battery and lead over the top of the battery toward the XT90 socket of the DeltaQuad Evo.



i The battery tray will move forward or backward to correct for the center of gravity depending on which payload is installed. Always make sure that no battery cable is located between the battery and the back wall of the battery bay.

! The main battery must be always installed in the battery bay as explained above. To extend the flight time and the total mission range of the DeltaQuad Evo, in addition to the main battery, the auxiliary battery can be installed in the payload bay.

Never attempt to fly only with the auxiliary battery as this will lead to an incorrect center of gravity. The main battery must always be installed.

Placing the auxiliary battery

Every DeltaQuad Evo comes with an auxiliary battery payload box.

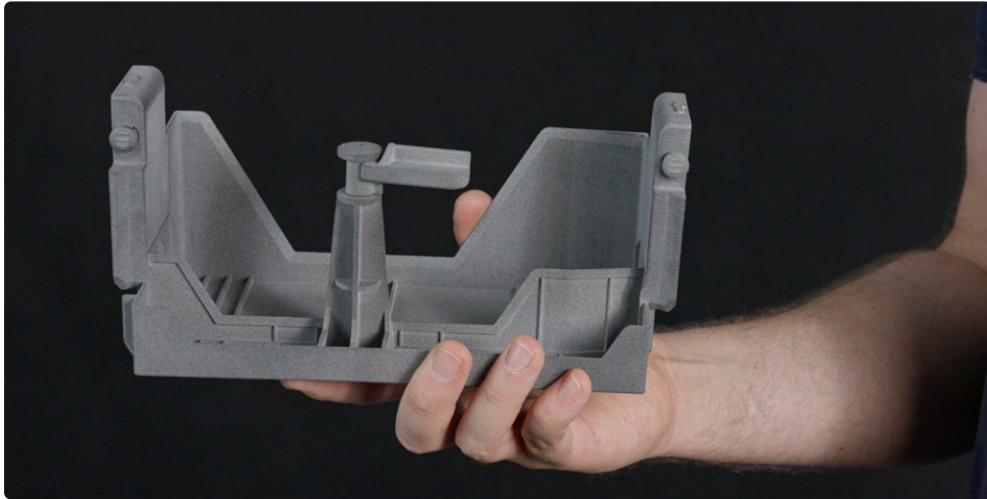

As with the main battery tray the auxiliary battery holder is shaped like the battery bottom plate.

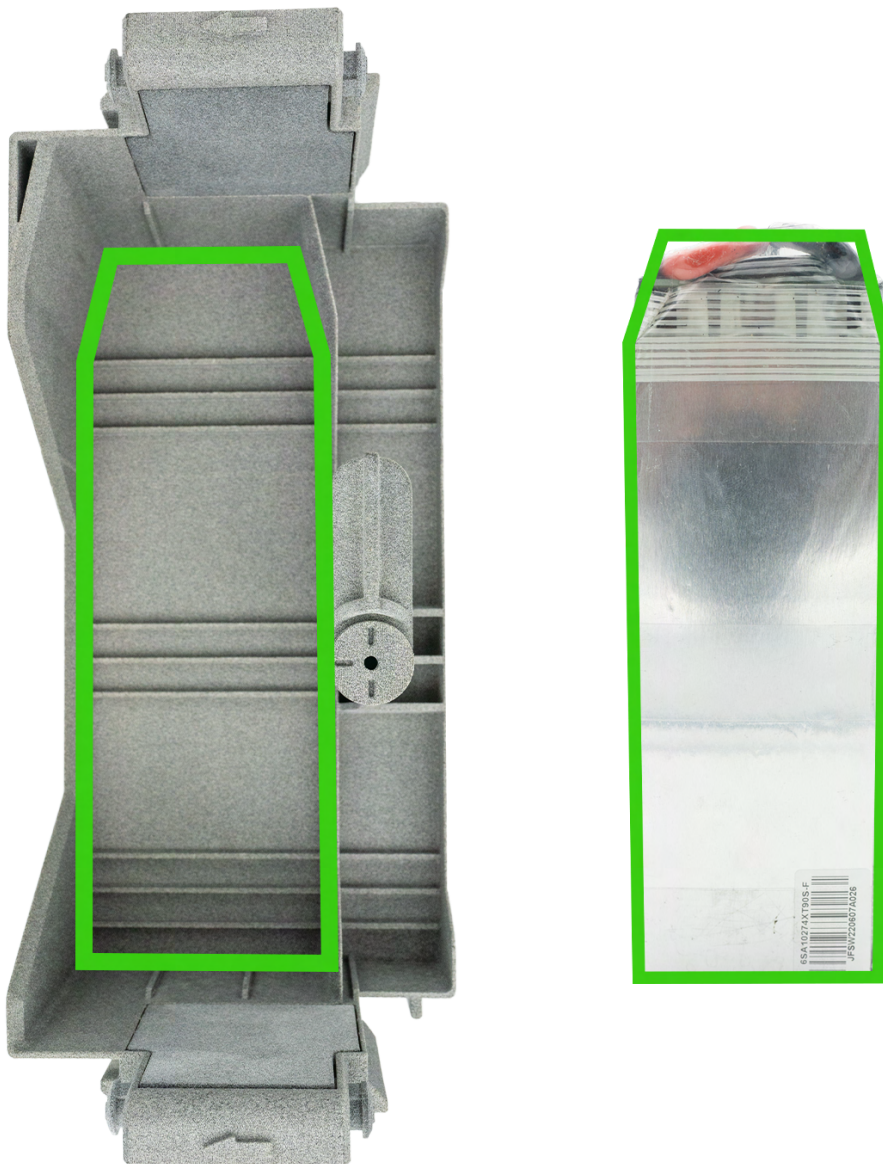

The auxiliary battery must be placed in such a way that it fits on the tray. The thicker power cables must exit the top of the battery and lead over the top of the battery toward the XT90 socket of the DeltaQuad Evo.



There is a latch mechanism on the auxiliary battery holder which secures the battery in place. After the battery is placed the latch needs to be rotated 90 degrees so it is positioned above the battery.



Installing the auxiliary battery payload box

 Always install fully charged batteries! Installing two batteries with different voltage levels can cause a fire.

 The auxiliary battery payload box must be installed in payload slot 1, the payload slot at the rear end of the fuselage, as it is the heaviest payload.

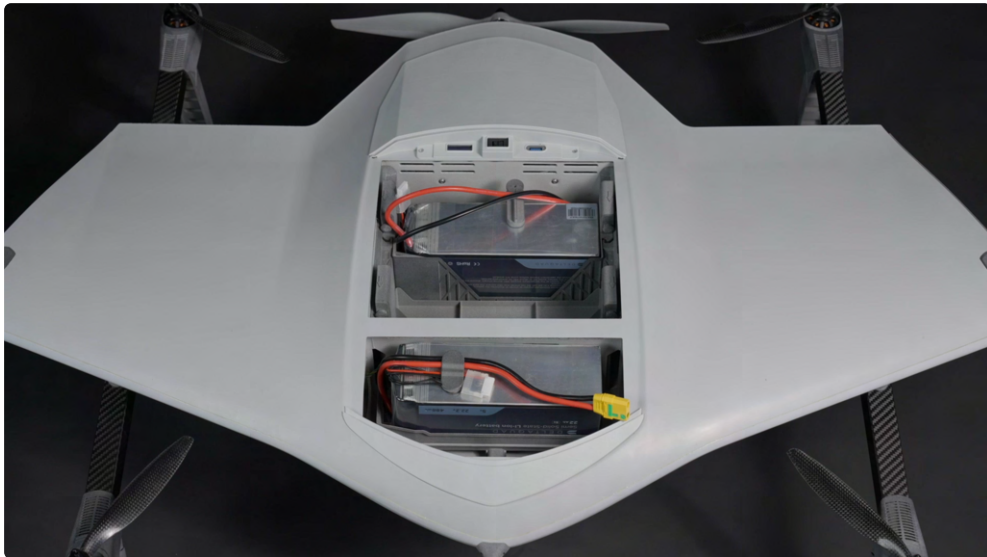

Every payload box displays two arrows on top of each handle.

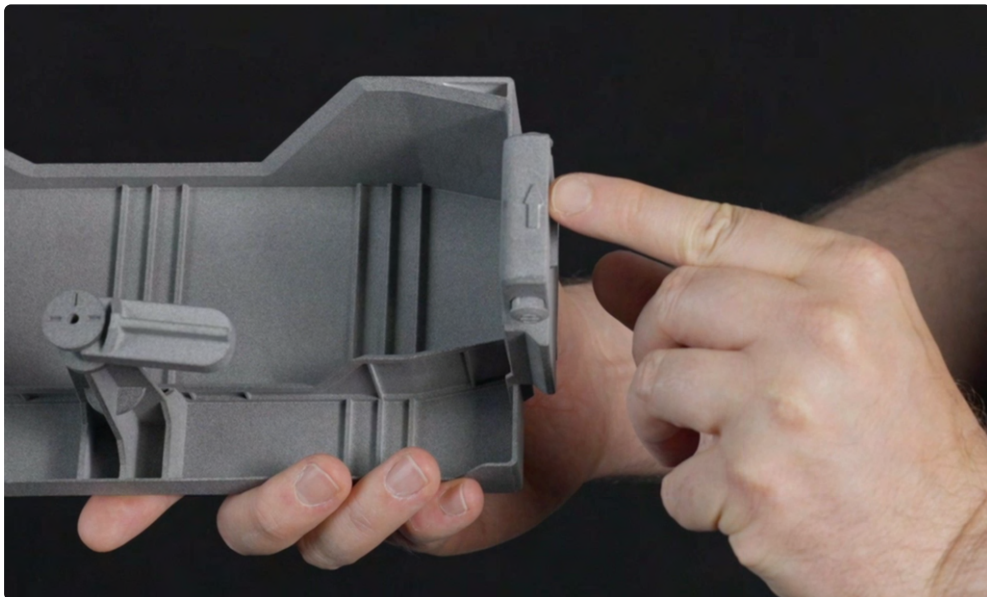

There are corresponding arrows on the left and right sides of the DeltaQuad Evo's payload bay.



The arrows of the payload boxes must match the arrows in the payload bay.

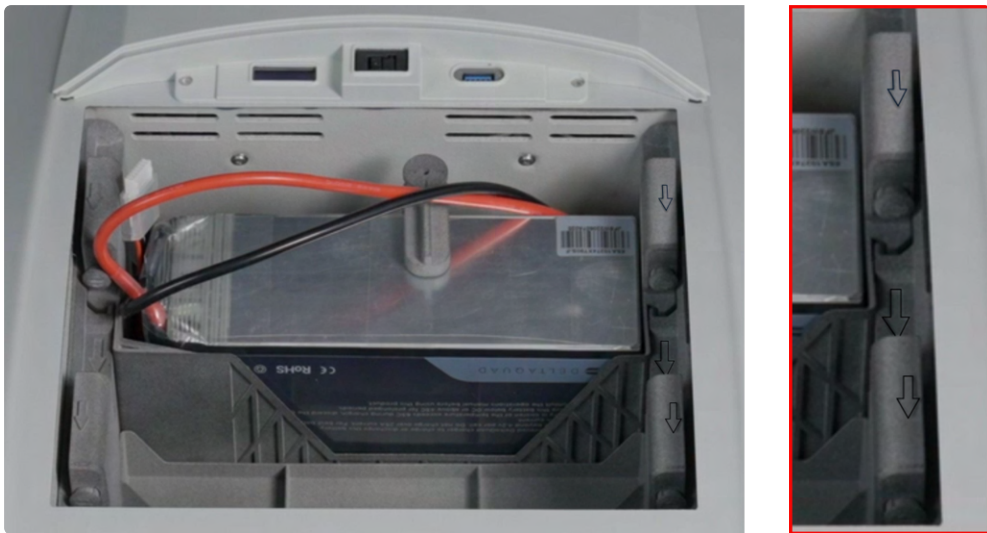

The payload box orientation is important as its I/O board must align with the respective I/O board of the payload slot.



Slide the payload box into the payload slot.



Push both payload box handles down until you hear a click from the payload box locking mechanism to make sure that the box sits properly in its slot.

The frame of a properly installed payload box sits flush with the frame of the payload bay.



Empty payload box

Before takeoff, the payload bay must be fully loaded with either two single payload boxes or one double payload box. If not the LCD above the avionics bay will read one of the following messages:



No payloads found



Slot 1: No payload



Slot 2: No payload

If payload slot 1 is loaded with, e.g. the Nighthawk 2, payload slot 2 needs to be loaded with the empty payload box which comes with every DeltaQuad Evo.



Powering the vehicle

In this section we will explain how to power on the vehicle.

After placing the main battery as described in the chapter [Battery placement](#) the XT90 connector of the battery needs to be connected to the XT90 socket in the battery bay.

The XT90 socket is located on the right side of the battery bay (front view).



The XT90 connector and socket have key features that allow for easy identification and proper alignment during connection. The constricting shapes at the left end of the connector and socket need to align. This design ensures that the connectors can only be plugged in one way.



Insert the XT90 connector of the battery into the XT90 socket of the Evo until fully joined.

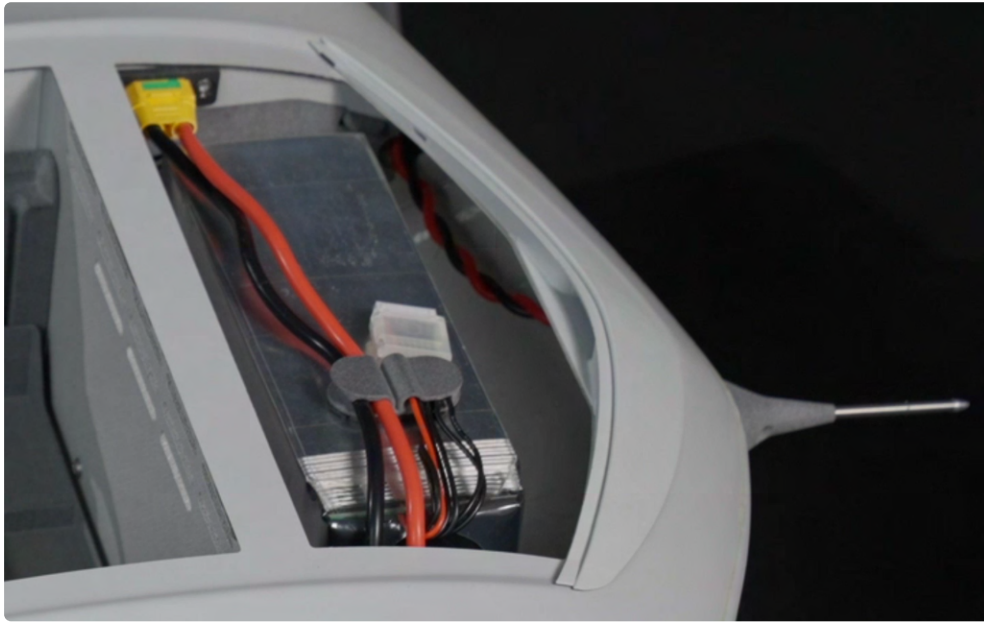

- i** Be sure to push the connector in fully to ensure a secure connection. If the connectors are not fully joined, the vehicle will still be able to switch on but the connectors could overheat. During the flight, due to vibration, the battery plugs could even come loose resulting in the vehicle losing power.

Vehicle initialization

When powering up the DeltaQuad Evo, it will go through an initialization routine that can be monitored on the Evo's LCD display located above the avionics bay:



DeltaQuad Evo starting the initialization



Checking payloads



First payload slot one will be identified



Secondly payload slot two will be identified

After the successful initialization, the LCD will read "Ready to fly".



The final message reads "Ready to fly"

- ⓘ If the initialization can't be completed due to an error, the LCD will give information indicating how to resolve it.

The following is a complete list of messages and their explanations.

LCD message	Explanation
Ready to fly	The vehicle has found no errors and is ready to fly.
Left wing not detected	The left wing is not detected. Please attach the left wing.
Right wing not detected	The right wing is not detected. Please attach the right wing.
Reverse payloads	The heaviest payload should be in the rear (slot 1). This message indicates that the payloads should be reversed. The payload in slot 1 should be installed in slot 2 and vice versa.
No payloads found	The software has not found any payloads. When flying without payloads the empty payload boxes (placeholders) need to be installed.
Slot 1: No payload	No payload was found in slot 1 (rear payload). Both payloads should be occupied. With a dual payload, this message should not appear.
Slot 2: No payload	No payload was found at slot 2 (front payload). Both payloads should be occupied. With a dual payload, this message should not appear.
Slot 1 not Configured	The payload printed circuit board (PCB) for the payload in slot 1 not been programmed.
Slot 2 not Configured	The payload printed circuit board (PCB) for the payload in slot 2 not been programmed.
Balancing Error XXmm	The payload makes the vehicle to nose or tail heavy and cannot offset the center of gravity (CG) with the nose battery (between -5 and +35 is ok).
Automatic balancing	The system is balancing the vehicle by moving the nose battery forward or aft.
Arming denied: XX	Arming UAV is denied because of reason XX.
Battery not fully charged	Battery level below 80%.
Nose battery moved XX mm	The vehicle moved the nose battery XX mm to offset the imbalance caused by the payloads.
Payload too heavy	The total payload weight is above 3000 grams. This is not within vehicle specifications.
Updating params	The vehicle parameters are being updated to accommodate the payloads.
Writing parameters failed	There was an error while writing the parameters.

Automatic vehicle balancing

Every payload box carries information about its weight and weight distribution. This information is stored on the I/O board of the payload box.

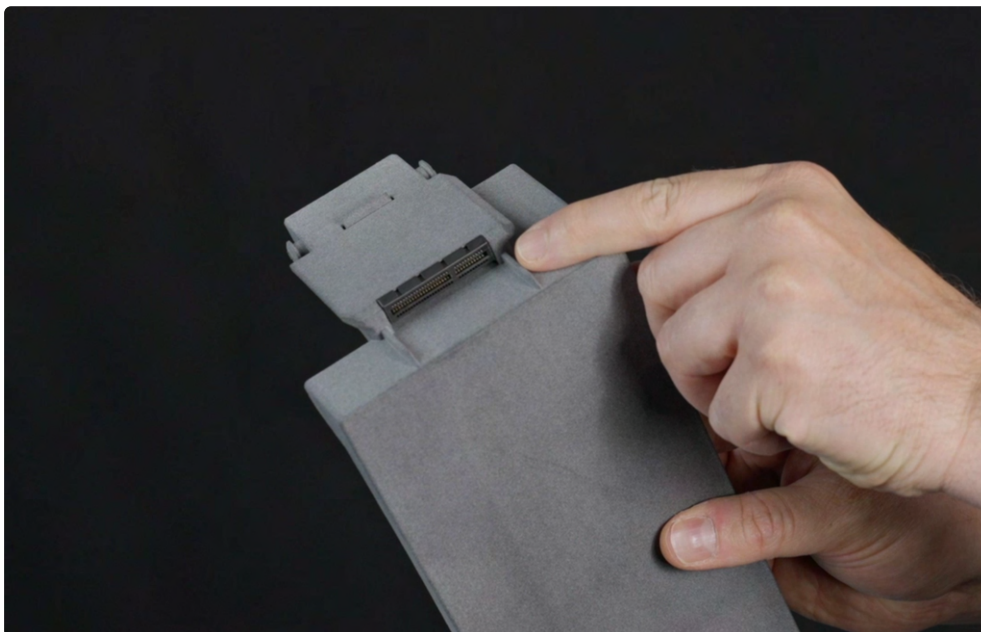

Depending on the installed payloads the DeltaQuad Evo will automatically balance itself by moving the main battery tray to the front or to the back.

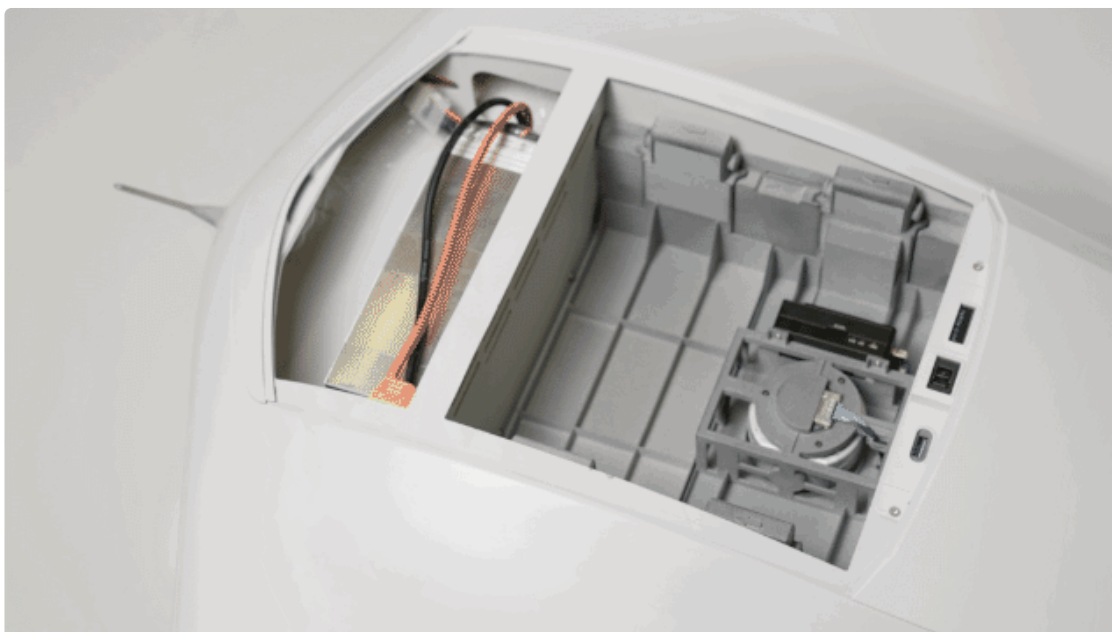

- i The DeltaQuad Evo can compensate to a greater extent for tail heaviness rather than nose heaviness. That is why the main battery tray can move more forward than backward. This is the reason why the heavier payload must be always installed in payload slot one, the most aft payload slot close to the pusher motor.

Safety features

This section covers the flight controller's safety features. To access the safety features configuration screen you will need to switch the vehicle on and establish a connection between the Ground Control Station and the vehicle.

Modifying the safety features

To modify the parameters click on the Menu Icon  in the upper left corner of Auterion Mission Control. A drop-down menu will open. Click on the Vehicle Setup tab.

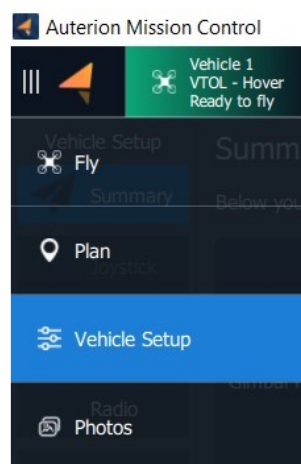

A new drop-down menu will appear. Click on the Safety tab.

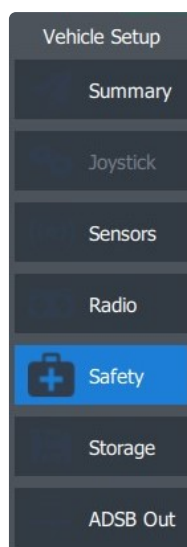

Now you have access to all safety settings.

Low Battery Failsafe Trigger

Default: Return at critical level, land at emergency level

Default Warn level: 10%

Default Failsafe level: 7%

Default Emergency level: 5%

These parameters define what the vehicle does when reaching low battery levels.

Note: The levels are those estimated to be reached when having flown to the landing site. This means that the further the vehicle is from its intended landing location, the sooner these actions will be taken. The vehicle will attempt to maintain these values when landed.

Warn level: The percentage where the vehicle will give a visible and audible warning to the Ground Control Station

Failsafe level: The level at which the vehicle initiates the critical battery action. (return)

Emergency level: The level at which the vehicle initiates the emergency battery action. (land)

RC Loss Failsafe trigger

Default: Disabled

The DeltaQuad EVO does not come with a traditional radio remote control. If such a transmitter/receiver is added this setting defines the behavior when the signal from this transmitter is lost. The DeltaQuad Controller will have both RC and DataLink functionality, but as these signals are sent over the same link it is recommended that you leave this setting disabled.

Data Link Loss Failsafe Trigger

Default: Disabled

Default timeout: 100s

This controls the behavior of the vehicle when the telemetry link is lost. When flying fully autonomous missions where the loss of telemetry is allowed or expected, this parameter should be set to Disabled.

Some local laws require this value to be set to "Return to Land".

The Settings of the Data Link Loss Failsafe Trigger should be checked before pausing the vehicle mid-flight.

If the trigger is disabled and the Data Link is lost after the vehicle is paused and in Hold Mode, the pilot has no possibility of giving a new pilot command. Until the Data Link is regained the DeltaQuad EVO will remain in Hold mode. If the Data Link can't be re-established the vehicle will remain in Hold Mode until the Low Battery Failsafe Trigger will be activated.

Geofence Failsafe Trigger

Default action: Warning

Default max radius: Disabled

Default max altitude: Disabled

The geofence failsafe trigger can be set to limit the vehicle's radius and/or altitude. When settings these parameters the vehicle will perform the defined action upon breaching any of these.

Return Home Settings

Default climb: 60m

Default home action: Land immediately

These settings define how the vehicle behaves when it engages the Return to Land function. The Climb altitude is the minimum altitude relative to home the vehicle will maintain for its return path.

If the altitude of the DeltaQuad EVO is lower than the Default climb value, in this case, 60 meters, the UAV will ascend to that Default climb altitude of 60 meters.

If the vehicle is higher at the point where the Return to Land is triggered it will maintain that altitude to return.

The DeltaQuad EVO can perform an autonomous Return to Land when instructed from the Ground Control Station, when instructed from a mission, or when triggered by a failsafe event.

If the DeltaQuad EVO is in Fixed-wing mode when the Return to Land event is triggered the UAV will make use of the Landing Pattern from the planned mission.

The DeltaQuad EVO will return in Fixed-wing mode to the Loiter waypoint of the Landing pattern in a straight line at the altitude the UAV is at when the RTL was initiated.

If the altitude of the DeltaQuad EVO is higher than the Default climb value the UAV will stay at its altitude and return to the Loiter Waypoint.

When reaching the "Loiter" waypoint the DeltaQuad EVO will loiter and descend to the set Approach Altitude. In the final approach towards the Land item, the DeltaQuad will perform a transition to Multirotor mode and land as planned in the mission.

Be aware that if your planned Land item is not at the same location as your Launch item, the DeltaQuad EVO will land in a different location rather than your Home Position.

If the DeltaQuad EVO is in Multirotor mode when the Return To Land event is triggered the UAV will return to the Land item in a straight line at the altitude it is at when the RTL was initiated.

Because the DeltaQuad EVO is in Multirotor mode it will not make use of the Loiter waypoint and the Landing Pattern but head directly for the Land item.

If the altitude of the DeltaQuad EVO is lower than the Default climb value (60m) the UAV will ascend to that Default climb altitude (60m) whilst heading for the Landing item.

If the altitude of the DeltaQuad EVO is higher than the Default climb value the UAV will stay at its altitude and return to the Landing Pattern.

When reaching the Land item the DeltaQuad EVO will descend in Multirotor mode and touchdown at the Land location.

Be aware that if your planned Land item is not at the same location as your Launch item, the DeltaQuad EVO will land in a different location rather than your home location.

Land Mode Settings

Default Descent Rate: 1,2m/s

Disarm after: 2s

This controls the landing behavior. The default descent rate is the maximum speed the DeltaQuad EVO descends in Multirotor during a landing.

In windy conditions, the vehicle will correct itself by applying a lower descent rate and the indicated descent rate might not be achieved. The DeltaQuad will brake and slow down its descent from approximately 8 meters above the Home Position to guarantee a soft landing.

The default value of the Descent Rate can be left at 1,2m/s. Nevertheless, if it needs to be changed it should not be increased above 1.5m/s.

The disarm time is the time the vehicle waits before disarming (stopping the motors) after it has detected a landing. The value should not be set lower than 2 seconds.

Flight

This chapter covers the command and control features of the vehicle.

Chapter index

- [Ground Control Station \(GCS\)](#)
- [Radio range and Line of sight \(LOS\) operation](#)
- [Ground Control Station overview](#)
- [Planning a mission](#)
- [Pre-flight checks](#)
- [Executing and monitoring a mission](#)
- [Post-flight](#)

Ground Control Station (GCS)

A Ground Control Station (GCS) refers to a centralized system or interface that allows operators to communicate with and control unmanned aerial vehicles (UAVs) or drones. The GCS serves as a command center where operators can monitor the drone's telemetry data, receive real-time video feeds from the drone's cameras, and send commands for navigation, flight parameters, and other operational tasks.



DeltaQuad Toughbook

The following section gives a basic overview of the DeltaQuad Toughbook and how to connect the handheld controller.

The DeltaQuad Evo TAC comes with the DeltaQuad Toughbook. Aterior Tactical Mission Control comes pre-installed. It provides the communication link between your UAV and the ground systems. The DeltaQuad Military Toughbook is a MIL-STD ruggedized touch-screen laptop. The device is constructed using the Panasonic TOUGHBOOK FZ-55 Touch with a magnesium chassis, flexible configurations, and a universal bay.



To charge the Toughbook please use the provided charging cable.



The handheld controller enables manual override and precision landing.



To connect the handheld controller to the Toughbook, plug the USB connector of the controller to any of the USB ports of the Toughbook.



Number	Type	Function
1	Left joystick	<p>In hover mode Stick up: climb Stick down: descend Stick left: yaw left Stick right: yaw right</p> <p>In fixed-wing mode (payload dependent) Stick up: gimbal up Stick down: gimbal down Stick left: gimbal left Stick right: gimbal right</p>
2	Right joystick	<p>In hover mode Stick up: move forward Stick down: move backward Stick left: move left Stick right: move right</p> <p>In fixed-wing mode Stick up: descend (nose down) Stick down: climb (nose up) Stick left: bank left Stick right: bank right</p>
3	Shoulder buttons L1 and R1	Gimbal zoom for ISR payload

Silvus StreamCaster 4240-EP

The following section gives a basic overview of the Silvus StreamCaster 4240-EP and how to assemble it.

The DeltaQuad Evo Tactical Edition comes with the Silvus StreamCaster 4240-EP. The unit consists of a handheld radio modem, two omnidirectional antennas, and a detachable battery.



At the top of the radio modem, you find the following connections:

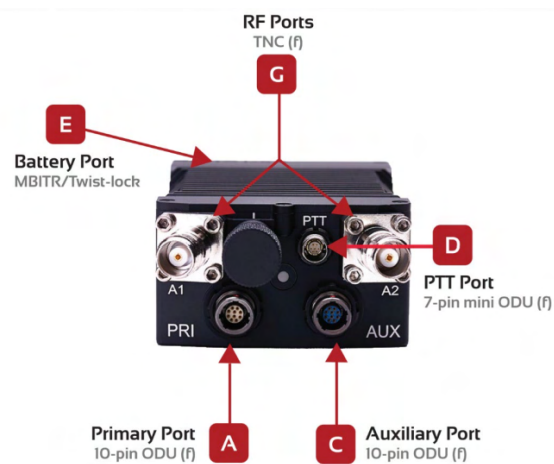

Attaching the antennas

Connect the two omnidirectional antennas to the RF ports (G).

Connect the SMA external antennas to the ports (5):



Attaching the battery

Connect the battery to the bottom of the radio modem. Align the battery in a 45-degree angle.

Connect the battery to the bottom of the radio modem. Align the battery in a 90-degree angle.



Connect both units and turn to align them.



To detach the battery for storage or charging, pull up the battery release latch on the side of the radio modem, and turn the battery until it is released.



Connecting the cable

The Silvus StreamCaster comes with a breakout cable. Connect the end with one plug to the Primary Port (PRI) of the radio modem.





To properly connect the plug to the socket, ensure that the red dots on both align.



To detach the cable for storage, simply pull the plug out of the PRI socket.

Connecting the GCS to the DeltaQuad Evo TAC

The following section describes how to establish a connection between the GCS and the DeltaQuad Evo TAC.

Getting started

Before connecting the GCS to your UAV, the Silvus StreamCaster must be connected to the Toughbook and both items must be switched on.

1. Plug the Ethernet cable from the Silvus breakout cable into the Ethernet port of the Toughbook.



2. On top of the Silvus radio modem pull out the rotary knob and set it to 1.





 Do **NOT** set the dial of the rotary knob to **Z**, as this is resetting the radio to its default settings. This makes the radio unusable.

i The Silvus StreamCaster 4240-EP is configured and set up properly in our factory. There is no need for further configuration. The system is plug-and-play ready.

3. Power on the Toughbook by pressing the on/off button.



i Before launching your flight control system it is recommended to connect the Toughbook to a mobile hotspot or Wi-Fi network. The Toughbook uses internet connectivity to load satellite maps and for LTE connectivity to the UAV.

4. Open Auterion Mission Control (AMC) on the Toughbook. The app shortcut is accessible from the desktop.

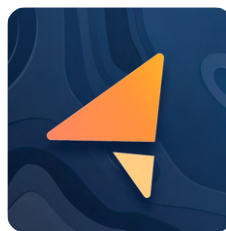

5. Switch on the DeltaQuad Evo. Follow the steps described in the chapter [Powering the vehicle](#).

6. During initialization, the GCS and the DeltaQuad Evo establish a connection automatically. The LED on the Silvus radio modem should turn from red to green.

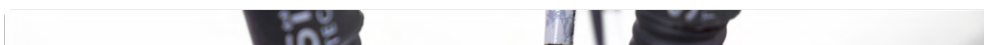



7. In the upper left corner of AMC, the vehicle status indicator will display a connection to the DeltaQuad Evo. When the indicator is green, the vehicle is ready for takeoff.

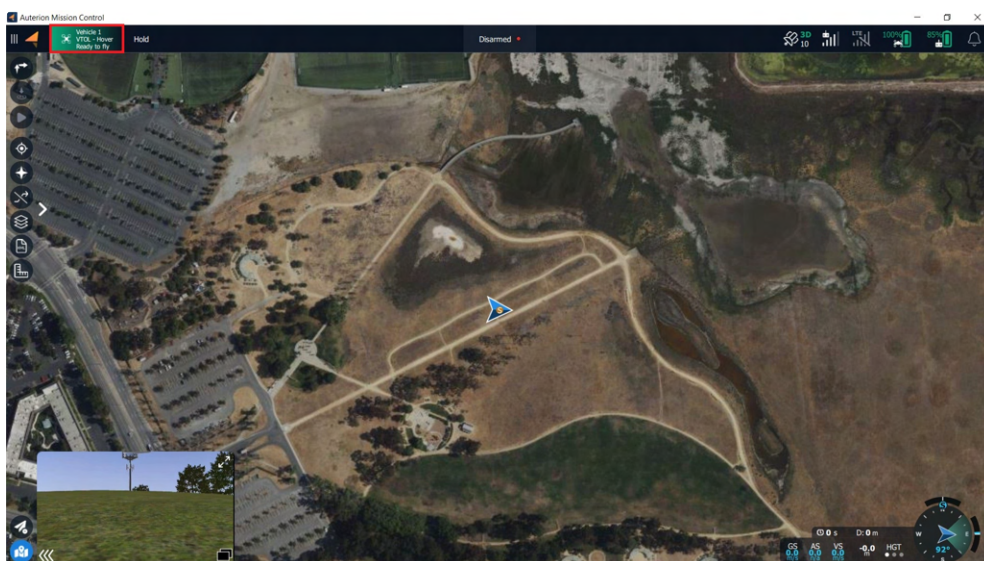

The connection between the GCS and the DeltaQuad Evo is established.

Optional tripod-mounted sector antenna

The following section describes the basic assembly and operation of the tripod-mounted sector antenna.

The tripod-mounted sector antenna gives up to 40 km ISR range extension. The horizontal field of view (beamwidth) is 120 degrees and the vertical field of view is 12 degrees. The tripod-mounted sector antenna requires a Silvus StreamCaster 4240-EP for standard operation.



Assembly

1. Mount and secure the antenna on the provided tripod.
2. Connect the double RF antenna cable to the RF ports of the antenna.





3. Connect the other end of the cable to the RF ports of the Silvus StreamCaster.

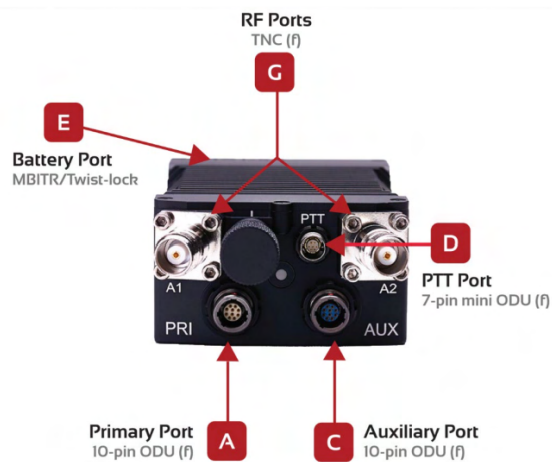

4. Connect the battery to the Silvus StreamCaster as described [here](#).
5. Connect the Silvus breakout cable to the Silvus StreamCaster and make sure to properly connect the plug to the socket, by aligning the red dots on the plug and the socket.



6. Mount the Silvus StreamCaster to the tripod with the provided Velcro.



7. To connect the GCS to the DeltaQuad Evo TAC please continue reading [here](#).

Positioning the tripod-mounted sector antenna

For general information and tips on radio range and line of sight operation, please read [here](#).

The optimal angle for a sector antenna to operate with a drone depends on several factors, including the

The optimal angle for a sector antenna to operate with a drone depends on several factors, including the antenna's beamwidth and the drone's flight path. A sector antenna typically has a directional beam that covers a specific angular range, often referred to as the beamwidth.

The provided tripod-mounted sector antenna has a horizontal beamwidth of 120 degrees and a horizontal beamwidth of 12 degrees.

Here are some considerations:

1. **Antenna Beamwidth:** Sector antennas have a specified beamwidth. The main lobe of the antenna's radiation pattern is within this beamwidth. Align the antenna so that the main lobe covers the area where the drone is expected to operate most frequently.
2. **Drone Flight Path:** Consider the expected flight path of the DeltaQuad Evo TAC. If the drone moves within a specific sector, align the antenna to cover that sector. It's common to point the sector antenna slightly angled upward, depending on the drone's altitude.
3. **Altitude Changes:** If the drone is expected to fly at different altitudes, you may need to adjust the tilt of the sector antenna to ensure coverage at varying heights.
4. **Obstructions:** Be mindful of any potential obstructions between the antenna and the drone. Adjust the antenna angle to avoid obstacles and maintain a clear line of sight.
5. **Coverage Area:** Determine the desired coverage area and adjust the sector antenna angle to match. Sector antennas are often used to cover specific sectors of a 360-degree area.

Silvus StreamCaster GUI

This section will discuss how to access the Silvus StreamCaster GUI for optional changes.

⚠ All Silvus radios come preconfigured and are ready to use. Changing the settings of the radio is only recommended for advanced users.

Each Silvus radio modem has a dedicated IP address consisting of 4 numbers divided by 3 dots. For example 172.20.123.123. Check your radio modem for the correct IP address.



i To get access to the Silvus StreamCaster GUI, the Toughbook must be connected to the Silvus StreamCaster and both units must be powered on.

1. On the Toughbook open a browser. In the address bar, type in the IP address of the radio modem and press enter.

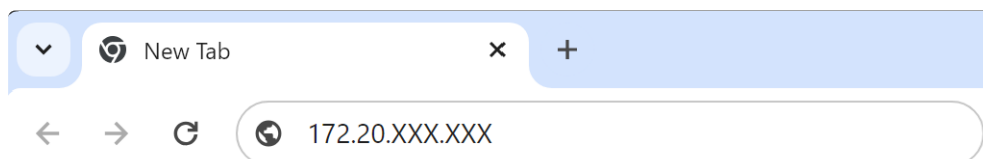

i If you are experiencing any issues with the Google Chrome browser while using the GUI, changing to an “incognito” window may help.

2. After a few seconds, the browser should open a window with the Silvus StreamCaster GUI. Under the tab Local Radio Configuration -> RF -> Basic, you have access to the basic radio frequency configuration. Here you can set for example the Frequency, Bandwidth, or Total Transmission Power.

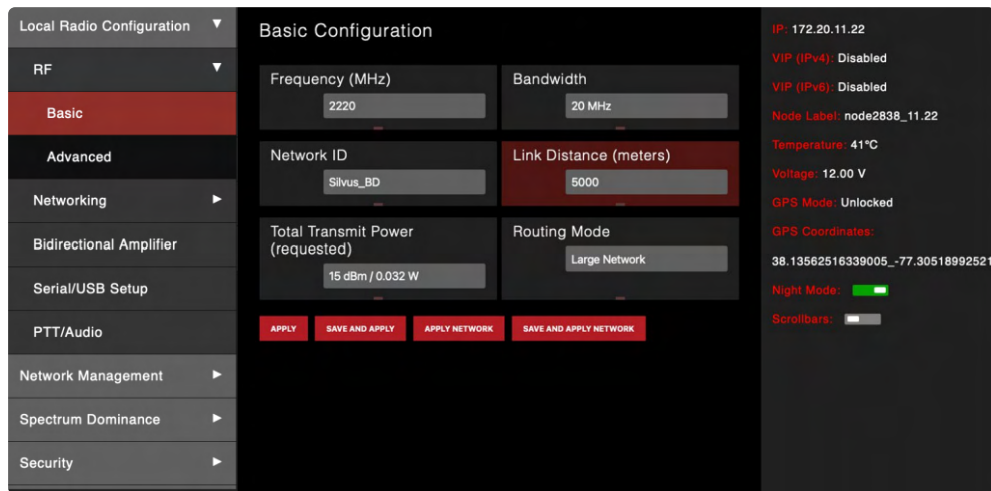

⚠ To function properly all changes must be applied to both the handheld radio and the DeltaQuad Evo. To save and apply changes to both, ensure that the units are powered on and connected. Choosing 'SAVE AND APPLY TO NETWORK' stores the changes in both devices, preserving them even after a reboot. 'APPLY' only stores the changes until a reboot.

ℹ The DeltaQuad Evo Tactical Edition comes with an Interference Avoidance License. When flying in areas where RF jamming is present, the system will use frequency hopping to provide the strongest link possible. The set frequency in the Basic Configuration serves as a starting point from which the system operates.

3. Under the tab Network Management -> Network Topology, the individual nodes and the signal strength are visible.

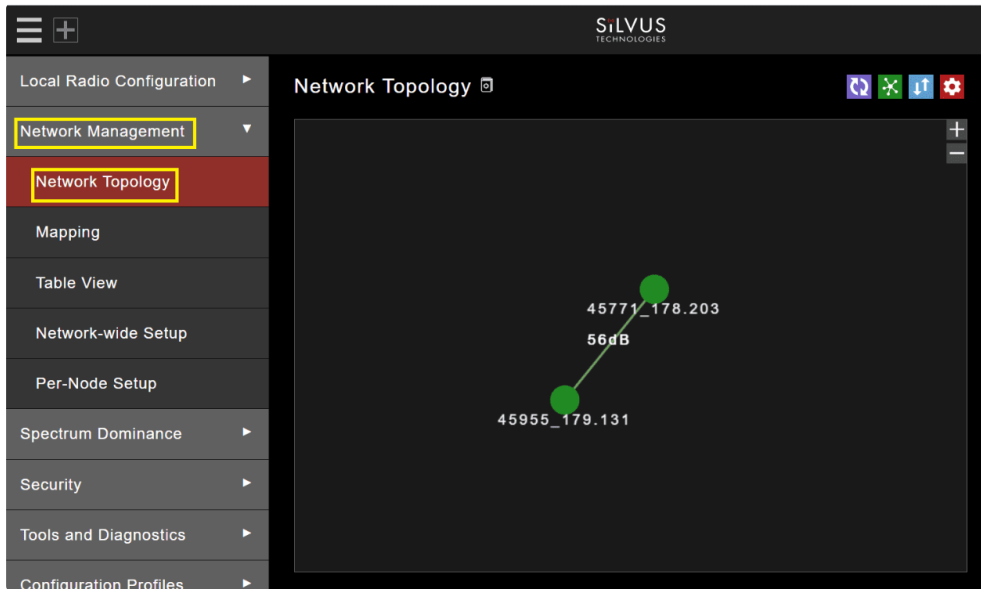

4. Under the tab Security -> Encryption, you can set the security keys.

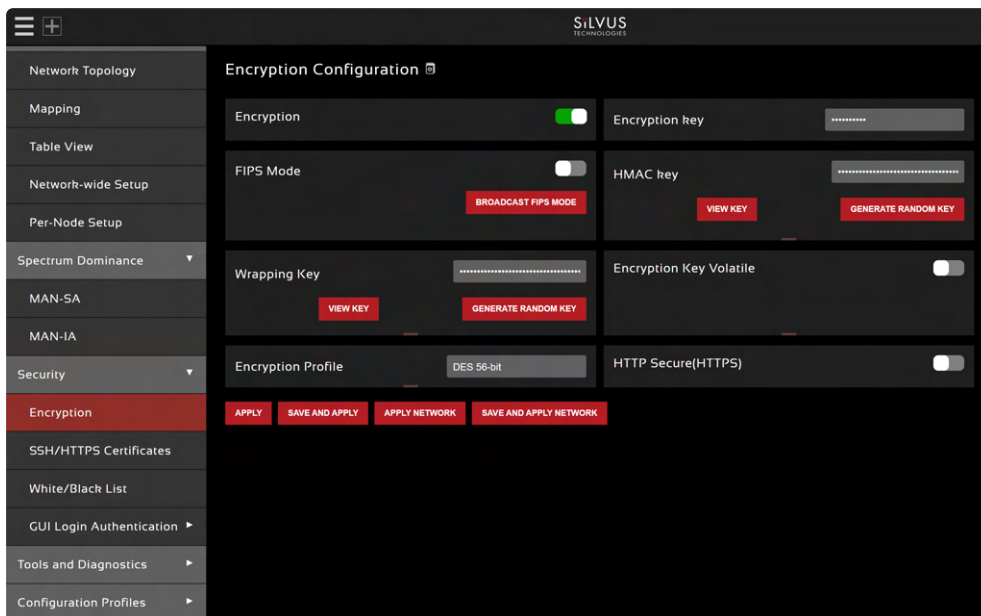

i During setup in our factory, we generate random keys which, for security reasons, are not stored anywhere. When changing the keys, make sure to save and apply the changes to both the handheld radio and the DeltaQuad Evo.

5. Under the tab Security -> White/Black List a white or black list can be created. A Black List can block specific nodes from the network. A white list can specify the nodes which are allowed to have access to the network.

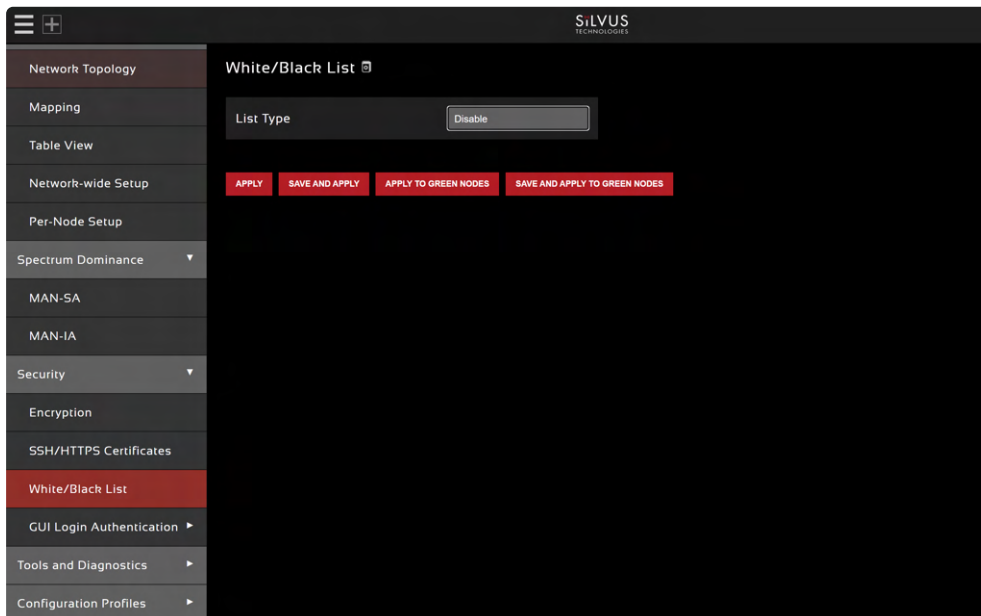

For further reading and in-depth information, please follow this [link](#).

ATAK-setup

The following section describes how to connect and set up an ATAK device.



ATAK stands for Android Team Awareness Kit. It is a mobile geospatial platform that enables real-time collaboration and communication among teams, particularly in military and emergency response scenarios. ATAK provides a map-based interface on Android devices, allowing users to share location data, mark points of interest, and communicate with team members in the field. It's designed to enhance situational awareness and coordination among team members by leveraging geospatial information in a user-friendly mobile application.

Required Hardware

- Skynav Tablet
- Data-Link
- Ethernet Switch
- Android device with ATAK installed (Application is available in the Google PlayStore) Connection

Procedure

1. Connect the Ground radio to the Ethernet switch.
2. Connect the tablet/phone running ATAK to the Ethernet switch
3. Connect the Ethernet switch to the Skynav
4. Power the Ethernet switch

AMC settings

1. Select  Settings > General.
2. Scroll down to Team Awareness (Smartphone Integration) section.
3. Turn on "Enable Team Awareness" and "Enable on startup". In Fly View, the Team icon will be highlighted in blue, indicating that ATAK functionality is enabled.
4. Set "Controller Callsign" to "Mission Control".
5. Set Destination Address to 172.20.255.255.
6. Set Destination Port to 4242.
7. Set Destination Protocol to UDP.
8. Set Incoming Port to 8089.
9. Set Incoming Protocol to UDP.

Team Awareness

Enable Team Awareness	<input checked="" type="checkbox"/>
Enable on startup	<input checked="" type="checkbox"/>
Controller Callsign	<input type="text" value="Mission Control"/>
Destination Address	<input type="text" value="172.20.255.255"/> 
Destination Port	<input type="text" value="4242"/>
Destination Protocol	<input checked="" type="radio"/> UDP <input type="radio"/> TCP
Incoming Port	<input type="text" value="8089"/>
Incoming Protocol	<input checked="" type="radio"/> UDP <input type="radio"/> TCP

ATAK settings

1. Click on the three dots on the top right. A menu will open.
2. Choose Settings > Network Connections. Click on "Network Connections" in the pop-up window.
3. Go to the Input/Output Management section and click on "Manage Inputs".
4. Edit the default connection (click on the pencil icon) and set address to 0.0.0.0.
5. Tick the advanced options a. Select Input Protocol to UDP. b Set Server Port to 4242. c. Confirm changes
6. The checkbox next to the default entry must be checked.
7. Go back to Input/Output Management. Click on "Manage Outputs".
8. Click on the three dots in the top right and select "Add". a. Set name to "AMC". b . Set address to 172.20.1.1
9. Tick the advanced options a. Select Input Protocol to UDP. b Set Server Port to 8089. c. Confirm changes
10. The checkbox next to the AMC entry must be checked.

Video settings

1. Click on the video symbol in the top toolbar. Click on the "+" in the menu.
2. Change type to "rtsp" in the popup-window.
3. Add 172.20.110.10:8553/stream1
4. Optionally: Stream can be named (e.g. "Vehicle 1")
5. Click on "Add". The stream will appear in the left menu.

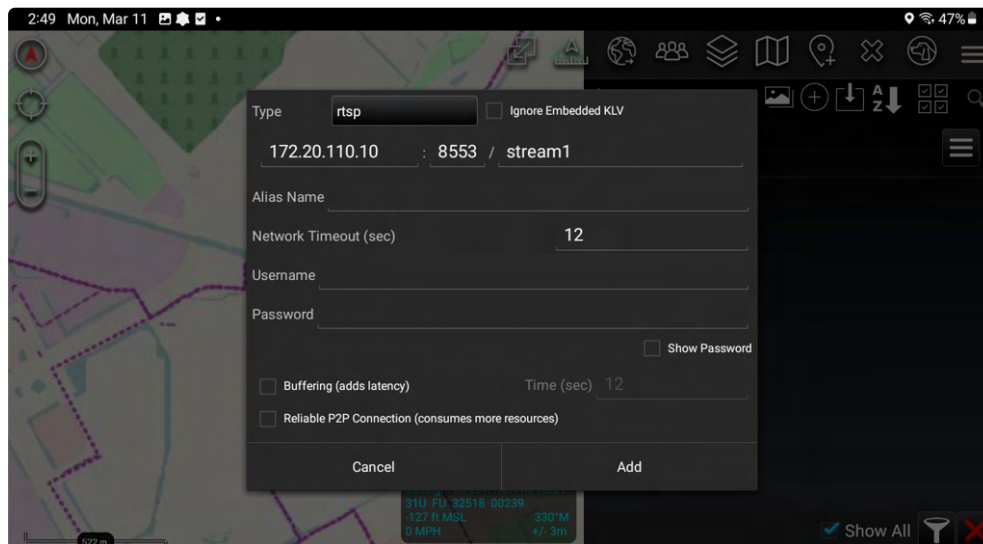

Using ATAK with Vehicle

1. Make sure to go through AMC-Settings, ATAK-Settings and Video-Settings first.
2. Connect the vehicle to AMC.
3. In ATAK, click on the three dots in the top right. A menu will appear. Click on "Settings" and then "Network Connections". A popup will appear. Click on "Network Connections". Check that the Primary IP Address is in the range 172.20.XX.XX. NOTE: If the Primary IP Address is in a different range, disconnect from the WiFi or cellular network.

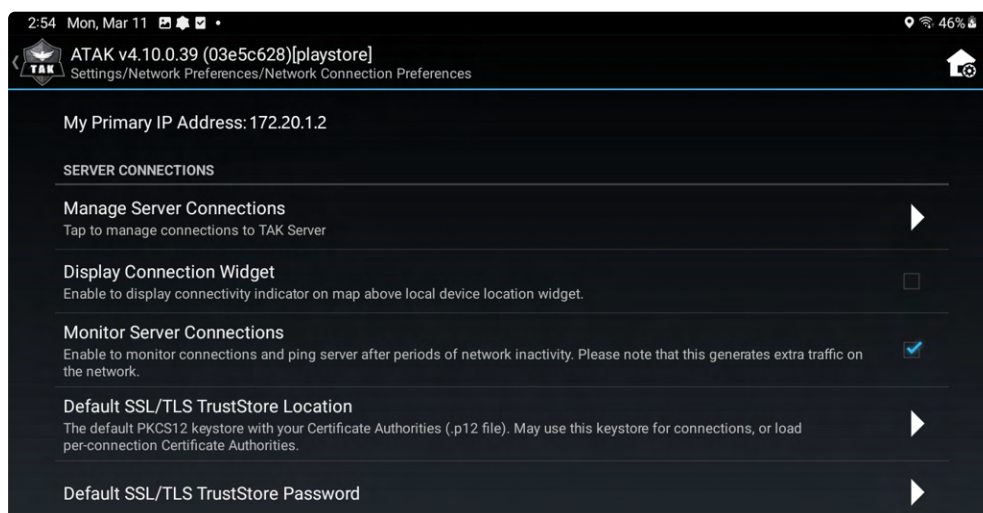

4. As soon as the vehicle has GPS-lock, the position as well as the sensor point of interest will appear on the map. NOTE: If the vehicle is on the ground, the sensor point of interest may not be visible.
5. Click on the video icon and select the stream previously configured in the ATAK configuration.

Markers

1. Select the marker icon in the ATAK top toolbar.
2. A menu with four different markers will appear on the right side.
3. Select the desired marker and click on the map to place the marker.
4. Click on "send" in the bottom right menu. You can either send the marker to a particular device or broadcast it.
5. The markers will appear in the map in AMC (Fly View only).

Controlling the vehicle

This section describes how to control your vehicle using the DeltaQuad Toughbook GCS.

Introduction

Auterion Mission Control (AMC) is pre-installed on your DeltaQuad Toughbook. This is the main application to control your UAV and the installed payload(s). For further reading, please read the chapter [Executing and monitoring a mission](#).

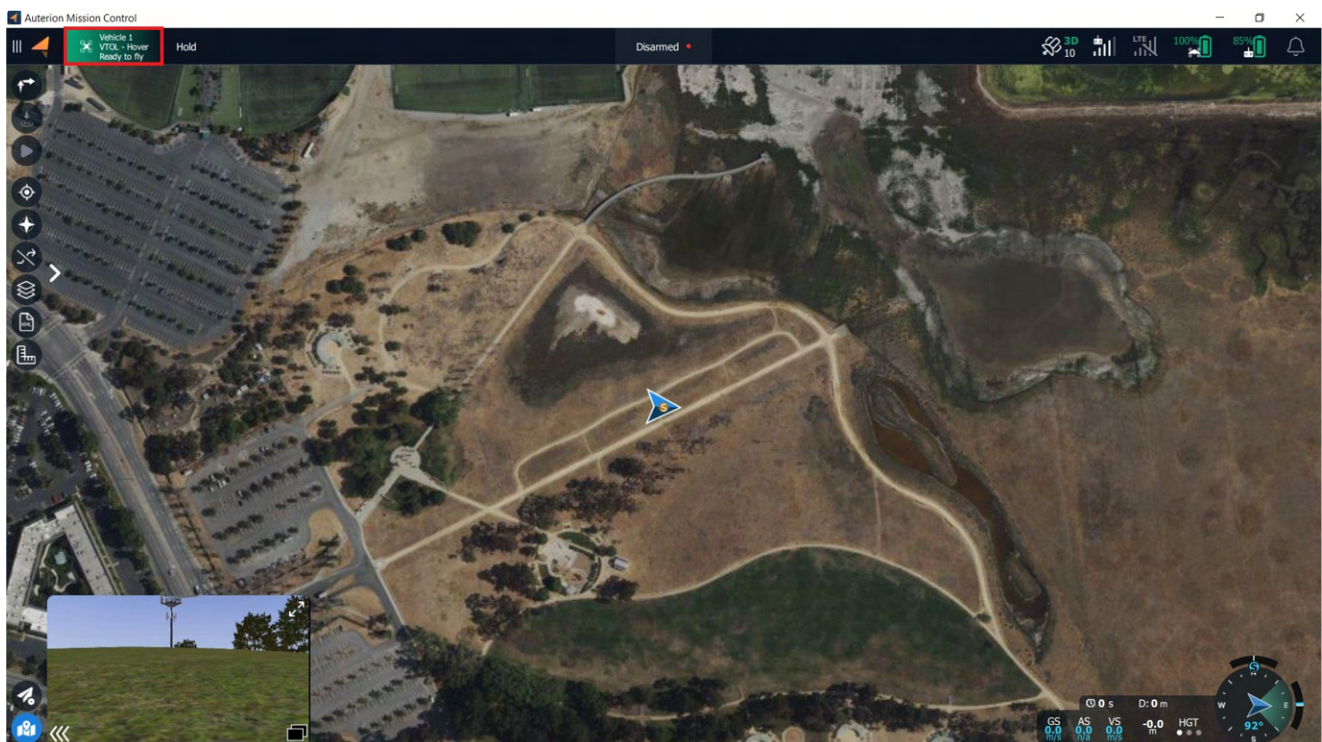

Mission planning

When flying a survey mission with a mapping sensor, or using a corridor scan to surveil a border, highway, or river, a full mission with a takeoff item, intermediate waypoints, and a land item can be planned in the Plan View.

You can switch to the Plan View via the AMC menu.

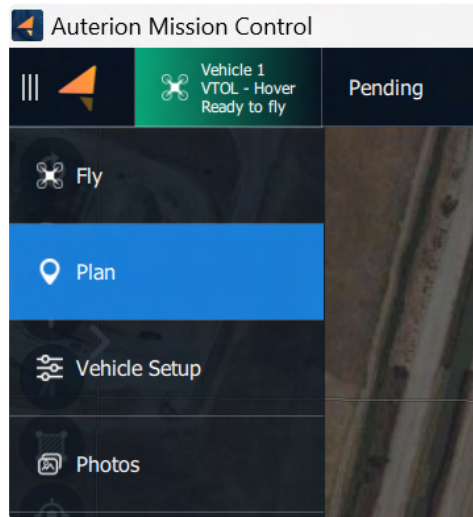

The mission plan can be executed fully autonomously from takeoff to the landing. It is also possible to take control of the vehicle after the takeoff and initiate a Return command when the mission has ended. The vehicle will use the landing pattern from the mission plan to execute a return command.

Please review the chapter [Planning a mission](#) for detailed information on how to plan a mission.

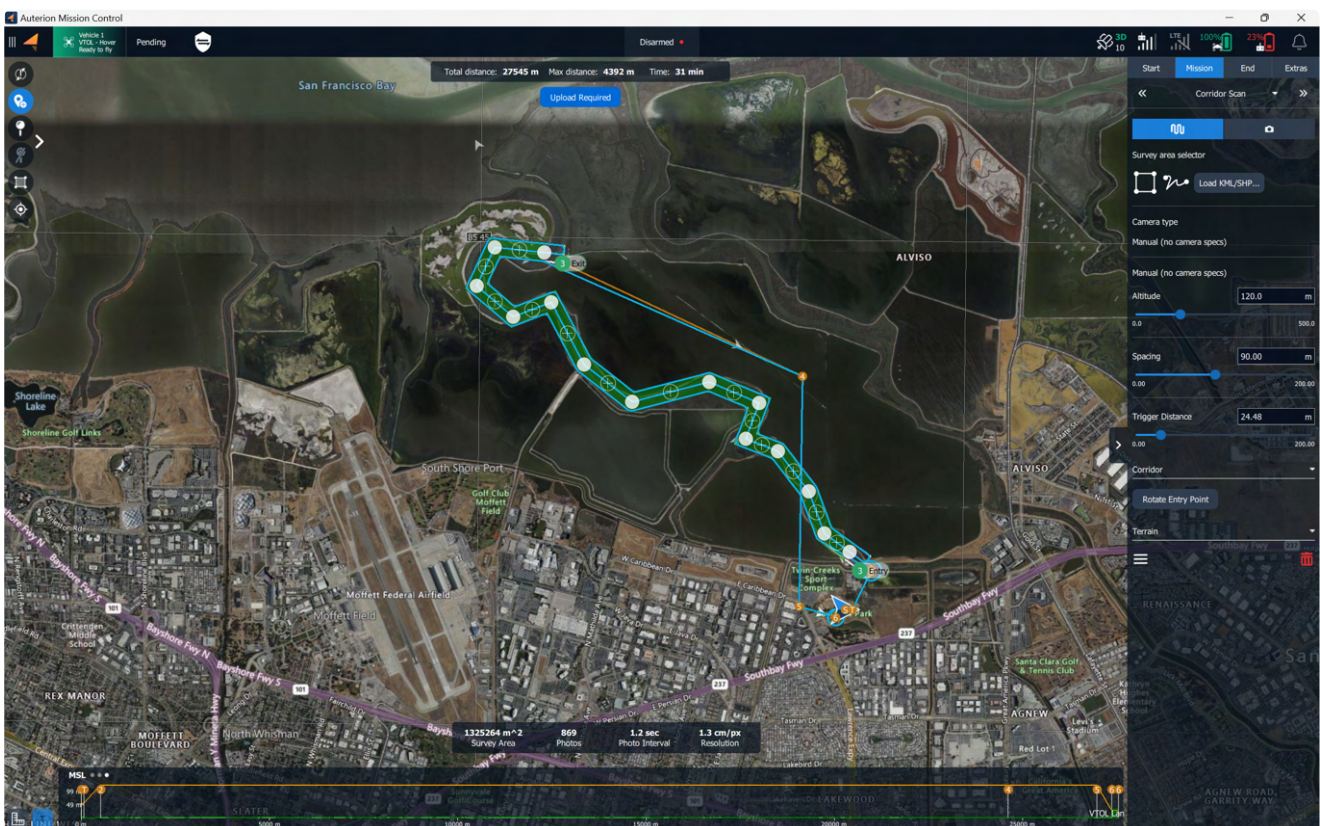

Quick takeoff

For a speedy deployment during a surveillance mission, it might be practical to plan only the takeoff and landing in the Fly View. When starting AMC, the Fly View is displayed. You can choose to plan the takeoff and landing in the Fly View.

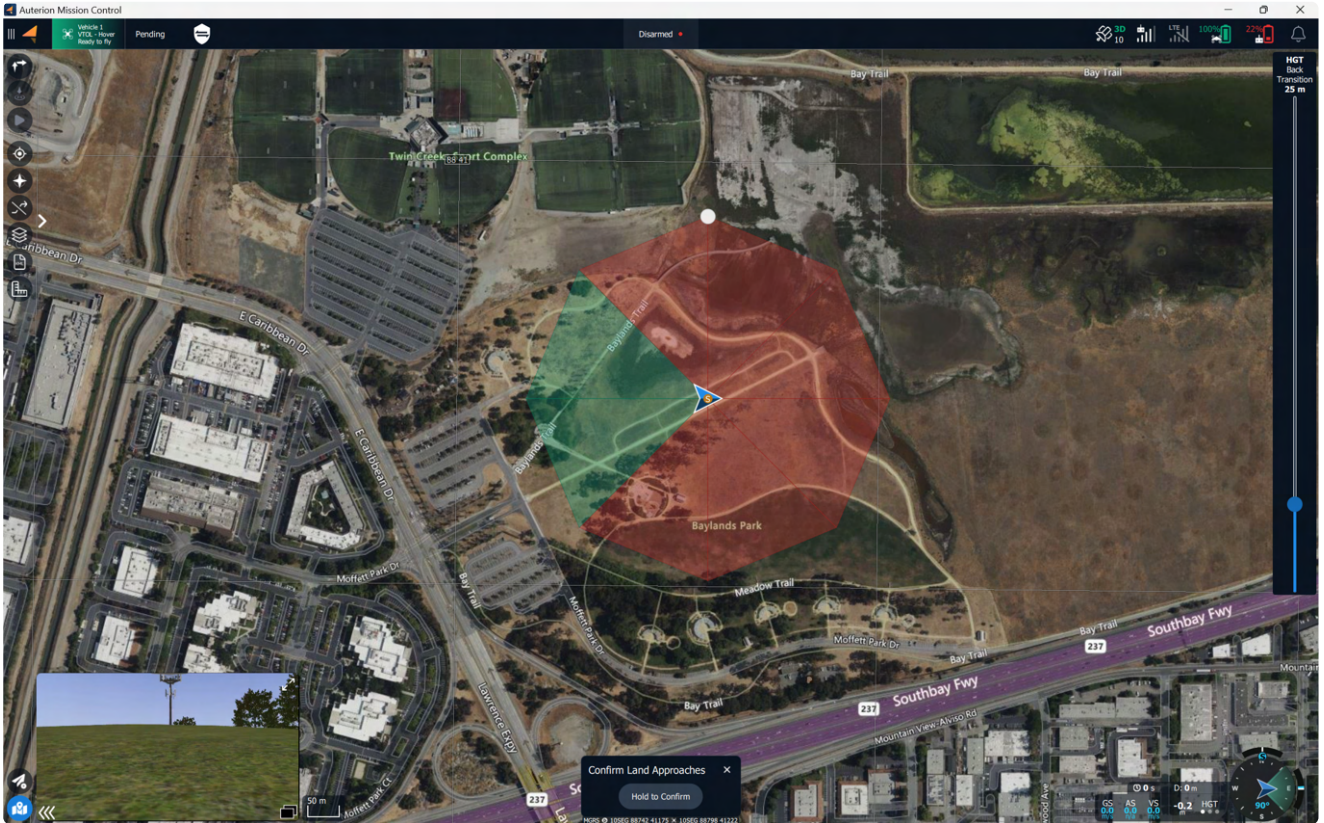

Launching your vehicle

Once your mission is uploaded, you can return to the Fly View by pressing the Fly View icon in the left-side command bar.

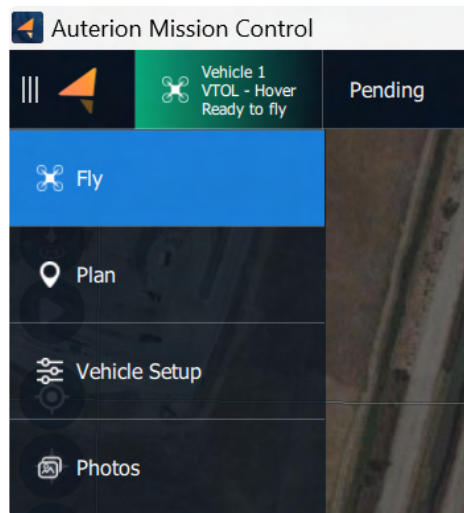

Once you have performed the [pre-flight checks](#), you can start the mission by pressing and holding the Start Mission button.

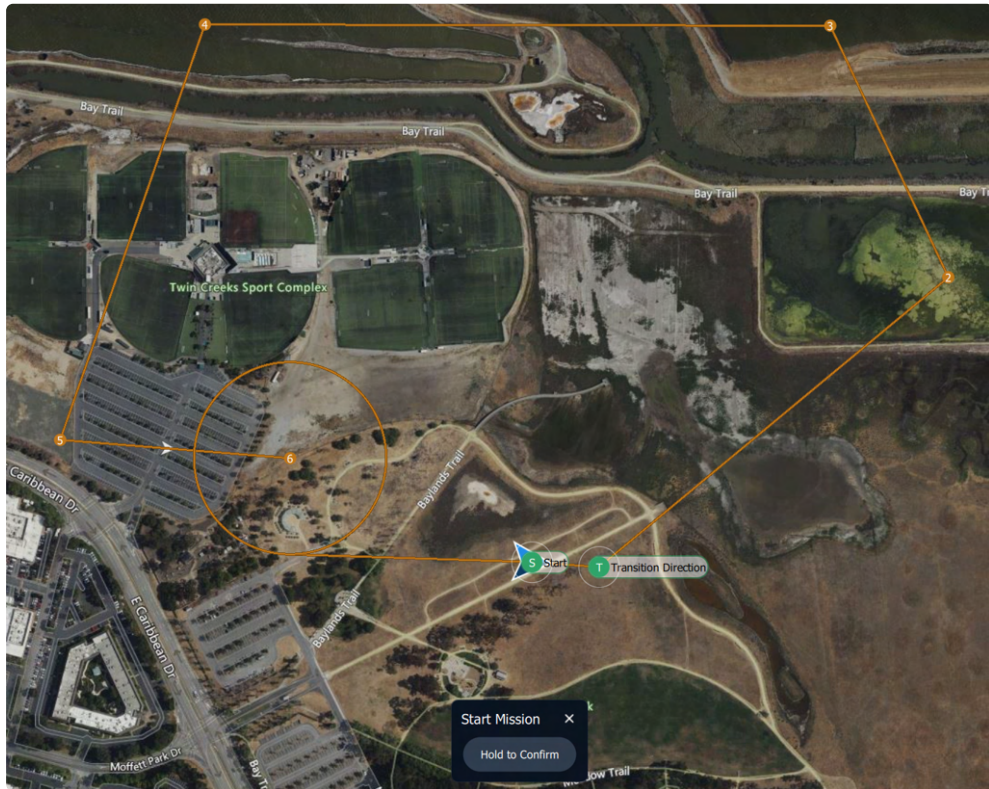

- i** If the Start Mission button is not displayed, you can press the Action button in the left-side command bar. The Mission Start button will reappear.

When pressing and holding to confirm the takeoff, your vehicle will start its motors and takeoff.

If you created a takeoff and landing in the Fly view, switching views is unnecessary. The vehicle will take off right after pressing and holding the VTOL takeoff button.

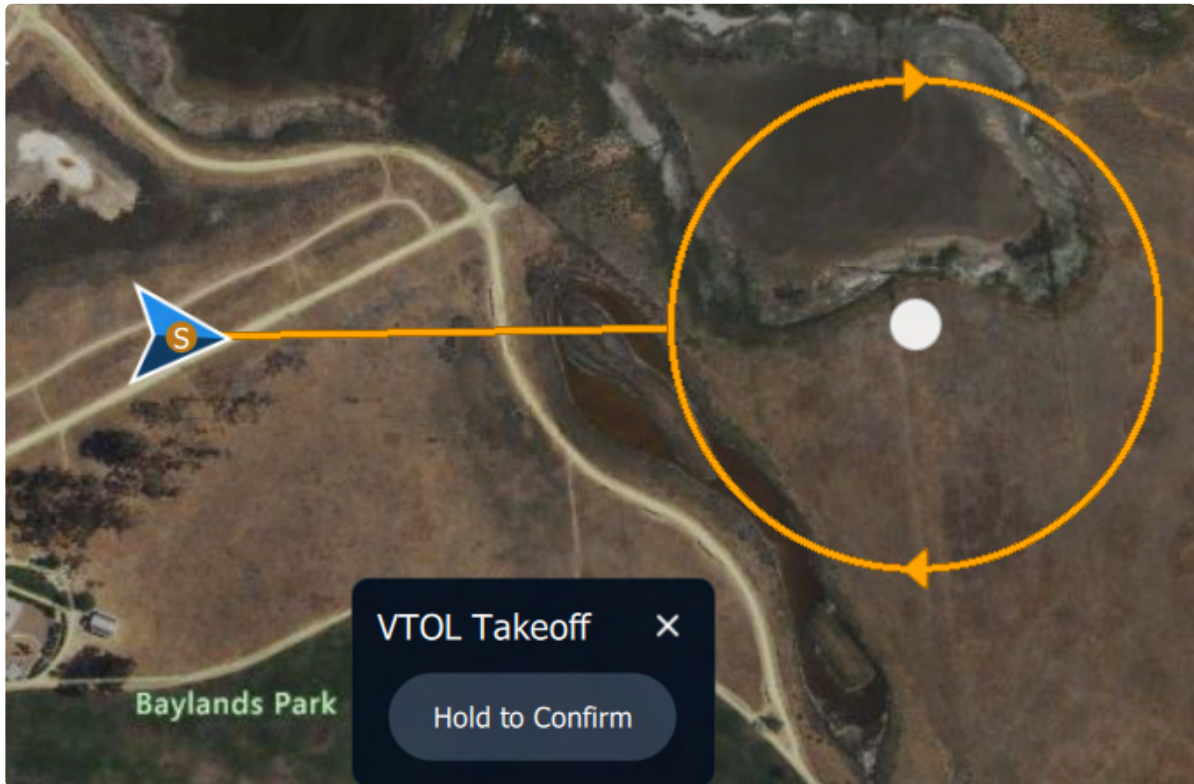

When pressing and holding to confirm the takeoff, your vehicle will start its motors and takeoff.

Operating your vehicle

Once the vehicle is launched and has transitioned to fixed-wing flight mode, you can control the flight of your vehicle through the following methods.

Repositioning the vehicle and changing altitude

While the vehicle is in flight, you can select the Orbit or Fig 8 command from the pilot controls on the left side of the screen.

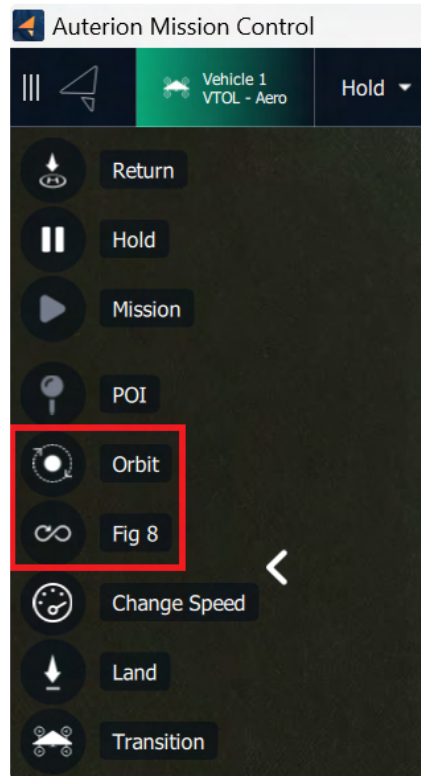

Tap anywhere on the satellite map to choose the Orbit's or Fig 8's location.

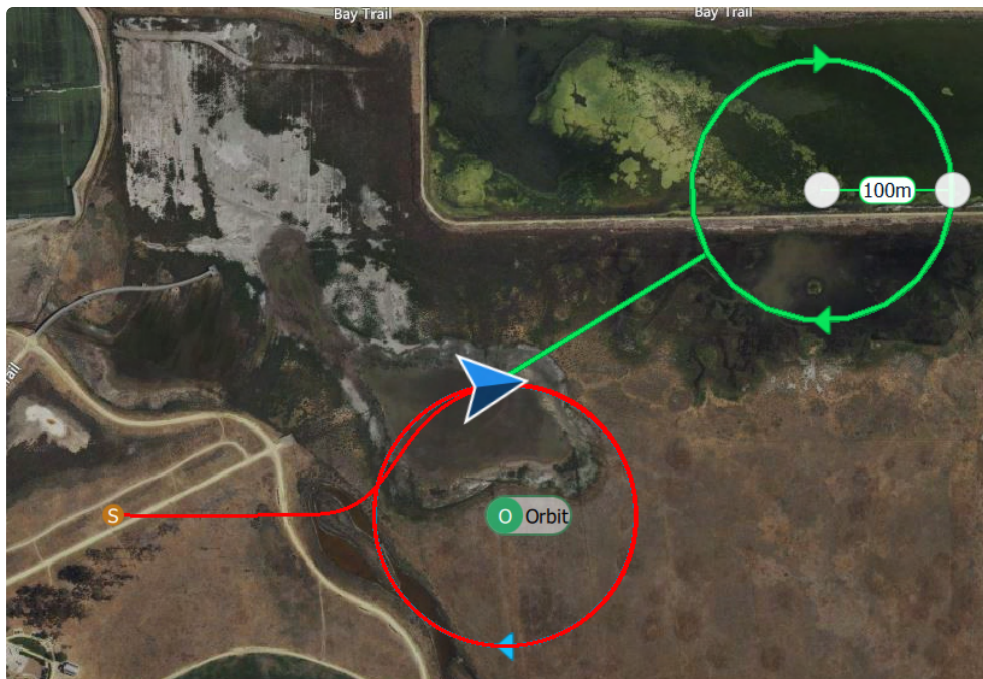

When giving an Orbit or Fig 8 command, the altitude can be changed. A vertical slider will appear on the right side of the screen that allows you to select a new altitude.

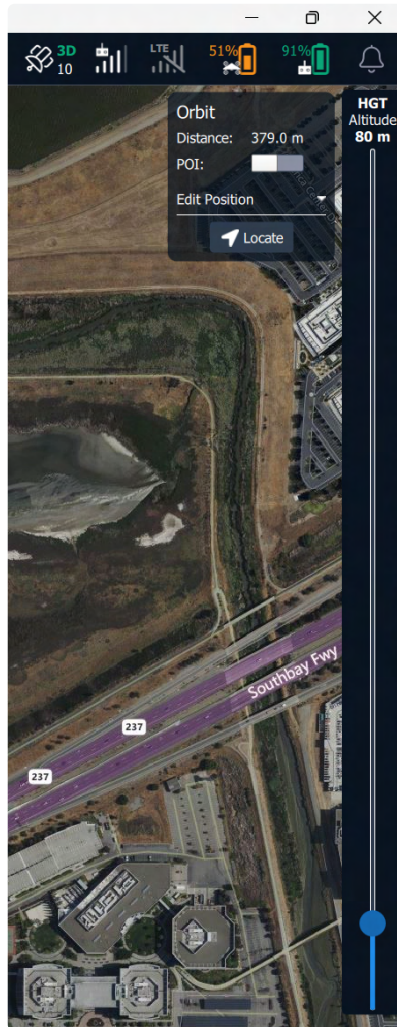

After confirming the command by pressing and holding the command button, the vehicle will change course to the set location and adapt to the set altitude.

- i** When the vehicle is following a mission path, it will always track the altitude as defined in the mission plan. When resuming a mission the vehicle will immediately change the altitude to match the currently active waypoint.

Joystick control

The vehicle can be controlled using the right-side joystick.



To activate the joystick control, switch the flight mode to ALTITUDE mode. In the Fly view, click on the Flight mode button in the upper left corner.

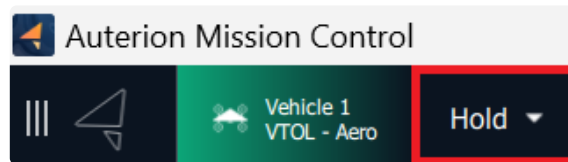

A menu with the available flight modes will open, choose Altitude.

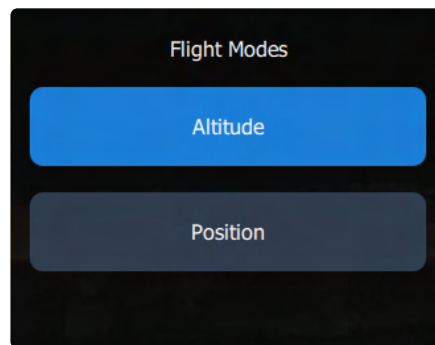

In this mode, the vehicle will fly in a straight line at its current altitude until a joystick command is received.

Moving the joystick left or right will make the vehicle change direction.



Moving the joystick forward or backward controls the altitude of the vehicle. A forward (up) joystick movement moves the nose of the vehicle down and decreases altitude. A backward (down) joystick movement pulls the nose of the vehicle up and increases altitude.



i If the vehicle loses connection to the DeltaQuad Controller while it is flying in Altitude mode, it will automatically return home, regardless of the Safety settings.

Flight modes explained

- Altitude mode - The DeltaQuad will automatically hold its altitude and direction until changed by the stick input. For flight stabilization and navigation, it will only rely on the IMU and not make use of the compass and GPS.
- Position mode - The DeltaQuad will automatically hold its altitude and direction until changed by the stick input. For flight stabilization and navigation, it relies on the IMU and makes use of the compass and GPS.

i NOTE: For inexperienced pilots, the joystick controls can seem counterintuitive. It is recommended to practice joystick operation in close proximity while flying at sufficient altitude.

Continuing a mission

When a mission plan is present, and the vehicle is in ALTITUDE, HOLD, or TARGET FOLLOWING mode, the mission can be resumed by tapping on the ACTION button on the FLY screen and selecting "Continue mission".

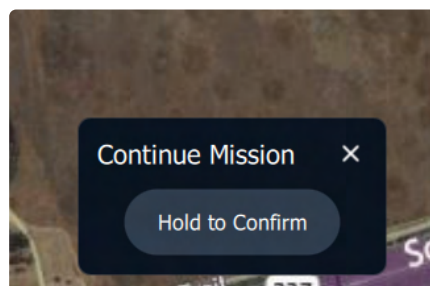
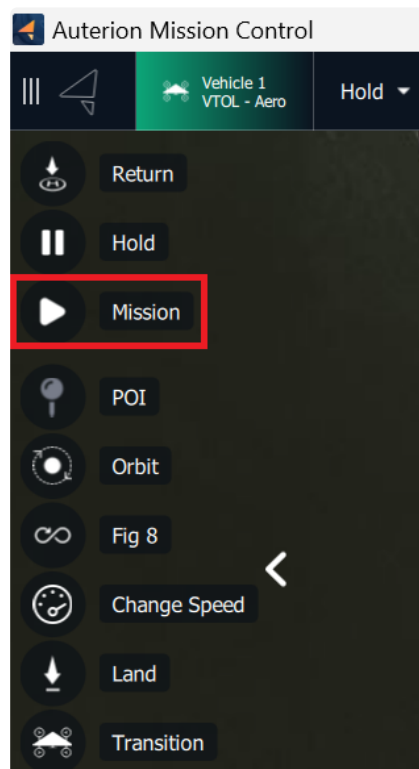

i Please make sure to disengage the TARGET FOLLOWING mode before returning to MISSION flight mode.

Returning the vehicle

At any point in the flight, the RETURN mode can be activated by tapping on the Return button on the FLY view and holding it to confirm the command.

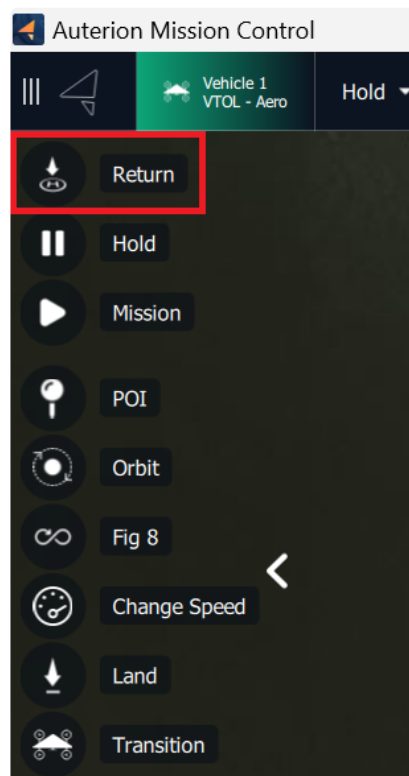

In RETURN mode, the vehicle will immediately fly towards the landing pattern that was defined in the mission. The landing pattern consists of a circle-to-altitude item, a direction and altitude on which to exit the circle, and a landing coordinate.

When the RETURN mode is activated, the vehicle will fly at its current altitude towards the 'circle to altitude' part of the landing pattern. When reaching this location, the vehicle will circle down to the indicated altitude, and complete the circle until it has reached the indicated exit heading of the circle. It will then proceed toward the landing coordinates, transition to multicopter flight mode, and land in the indicated position.

Controlling the vehicle in multicopter mode

! The multicopter mode should not be used for more than 90 seconds as the system can overheat when utilized longer.

The most common situation where it is practical to use stick control in multirotor mode is during the landing to reposition the Evo if necessary.

This can be achieved by using the NUDGE function.

After the Evo transitioned from fixed-wing mode to multirotor mode, the vehicle will deploy the landing gear and descend to the planned landing point.

The operator can halt the descent by moving the left joystick up.



The Evo will hold its altitude and position. The RIGHT joystick controls the position of the vehicle. Moving this joystick, forward, backward, left, or right changes the position of the vehicle relative to its current heading.



The LEFT joystick controls the vehicle's altitude and heading. Moving the joystick UP will halt the descent. Moving the joystick to its middle position or down will continue the descent. Moving the joystick left or right changes the heading (yaw) of the vehicle.



⚠ It is not recommended to fly manually in multirotor mode for longer than 90 seconds.

During takeoff or landing, your vehicle is in multirotor mode. Multirotor mode means the 4 motors for Vertical takeoff and Landing are activated.

To take control of the vehicle in multirotor mode, change the flight mode switch to ALTITUDE mode. In this mode, the vehicle will hold its position and altitude until joystick commands are received.

The LEFT main joystick controls the vehicle's altitude and heading. Moving the joystick UP will increase the altitude. Moving the joystick down will decrease the altitude. Moving the joystick left or right changes the heading (yaw) of the vehicle.



The RIGHT joystick controls the position of the vehicle. Moving this joystick, forward, backward, left, or right changes the position of the vehicle relative to its current heading.



Radio range and Line of sight (LOS) operation

Line of sight (LOS) is a crucial consideration for drone radio systems, as it directly impacts communication reliability and performance.

Understanding Line of Sight (LOS):

Line of sight refers to the unobstructed path between two points, such as between a drone and its remote control or between two communication devices. Maintaining a clear line of sight is essential for reliable communication regarding radio systems on drones.

Importance of LOS for Radio Systems on Drones:

1. Signal Strength:

- Radio signals, including those used for drone communication, travel in straight lines. Any obstacles, like buildings or trees, can weaken or disrupt the signal.
- LOS minimizes signal interference, ensuring a strong and stable connection between the drone and the remote control.

2. Reliability and Stability:

- A clear line of sight enhances the reliability of communication. This is particularly crucial for real-time control of drones, where a delay or loss of signal could lead to accidents or loss of the drone.

3. Range Limitations:

- The effective range of radio signals is limited. Maintaining LOS allows the drone to operate within its specified range, ensuring that commands from the remote control reach the drone and vice versa.

Factors Affecting LOS:

1. Physical Obstacles:

- Buildings, hills, and other physical structures can obstruct the line of sight. It's essential to fly the drone in areas with minimal obstructions for optimal communication.

2. Environmental Conditions:

- Weather conditions, such as heavy rain, fog, or snow, can also affect LOS. In adverse weather, LOS

may decrease, leading to potential communication issues.

3. Frequency and Wavelength:

- The frequency of the radio signal used by the drone affects its ability to penetrate obstacles. Higher frequencies may have more difficulty passing through obstacles, emphasizing the need for LOS.

Fresnel Zone

The Fresnel zone, in the context of drone radio systems, is a critical concept related to the propagation of radio waves between the transmitter (typically the remote control) and the receiver (the drone). It plays a significant role in ensuring reliable communication by accounting for potential obstacles that might impact the signal's path.

Key points about the Fresnel zone in drone radio systems:

1. Elliptical Zone:

- The Fresnel zone is an elliptical region that surrounds the direct line of sight (LOS) between the transmitter and the receiver. It extends both horizontally and vertically, forming an elongated shape.

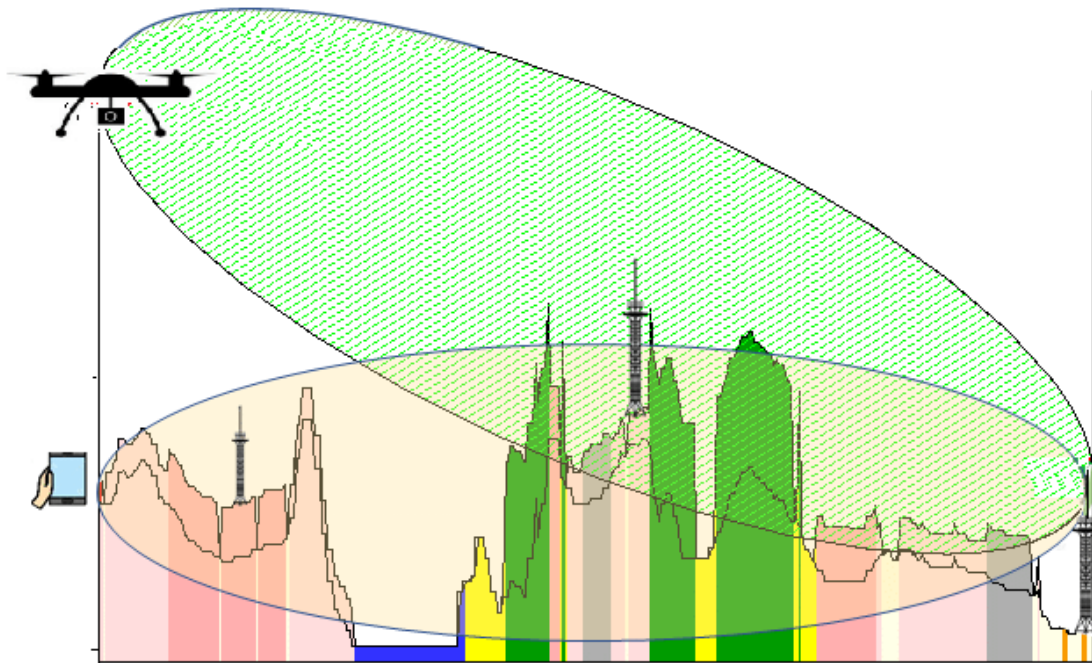

1. Importance for Signal Propagation:

- The Fresnel zone is crucial because it represents the area through which radio waves travel as they propagate between the transmitter and the receiver. An obstruction within this zone can cause signal diffraction, leading to signal weakening or disruption.

2. **Factors Influencing Fresnel Zone:**

- The size of the Fresnel zone depends on several factors, including the distance between the transmitter and receiver, the frequency of the radio signal, and the terrain along the path.

3. **Clearance for Unobstructed Signal:**

- For optimal signal strength and reliability, it is essential to ensure that the Fresnel zone is relatively free of obstructions. Obstacles within this zone, such as buildings, trees, or hills, can cause signal degradation.

4. **Interference Avoidance:**

- Understanding the Fresnel zone is crucial for avoiding interference from obstacles and maintaining a robust communication link between the drone and the remote control. Interference can lead to signal loss, reduced control range, and potential safety hazards.

Tips for Maintaining LOS:

1. **Choose Open Spaces:**

- Fly drones in open areas with fewer obstructions to ensure a clear line of sight.

2. **Monitor Environmental Conditions:**

- Be aware of weather conditions that could impact LOS. Avoid flying in heavy rain or foggy weather.

Understand Regulations:

Adhere to local regulations that may require maintaining visual line of sight with the drone. These regulations are often in place to ensure safety and prevent accidents.

In summary, maintaining a clear line of sight is crucial for the effective operation of radio systems on drones. It ensures reliable communication, stable control, and compliance with regulations, contributing to a safer and more efficient drone flight experience.

Ground Control Station overview

The DeltaQuad EVO uses Auterion Mission Control (AMC) as its primary Ground Control Station (GCS). The Ground Control Station consists of buttons and has been optimized for use with touchscreen devices.

If you have ordered a Ground Control Station with your DeltaQuad EVO it will have been installed and tested before it was shipped to you.

To install Auterion Mission Control on a separate device such as a laptop or desktop computer, please refer to the [Auterion Mission Control Installation Manual](#). After a successful installation make sure to follow the [First Steps](#).

When starting Auterion Mission Control by default the Fly View will be selected.

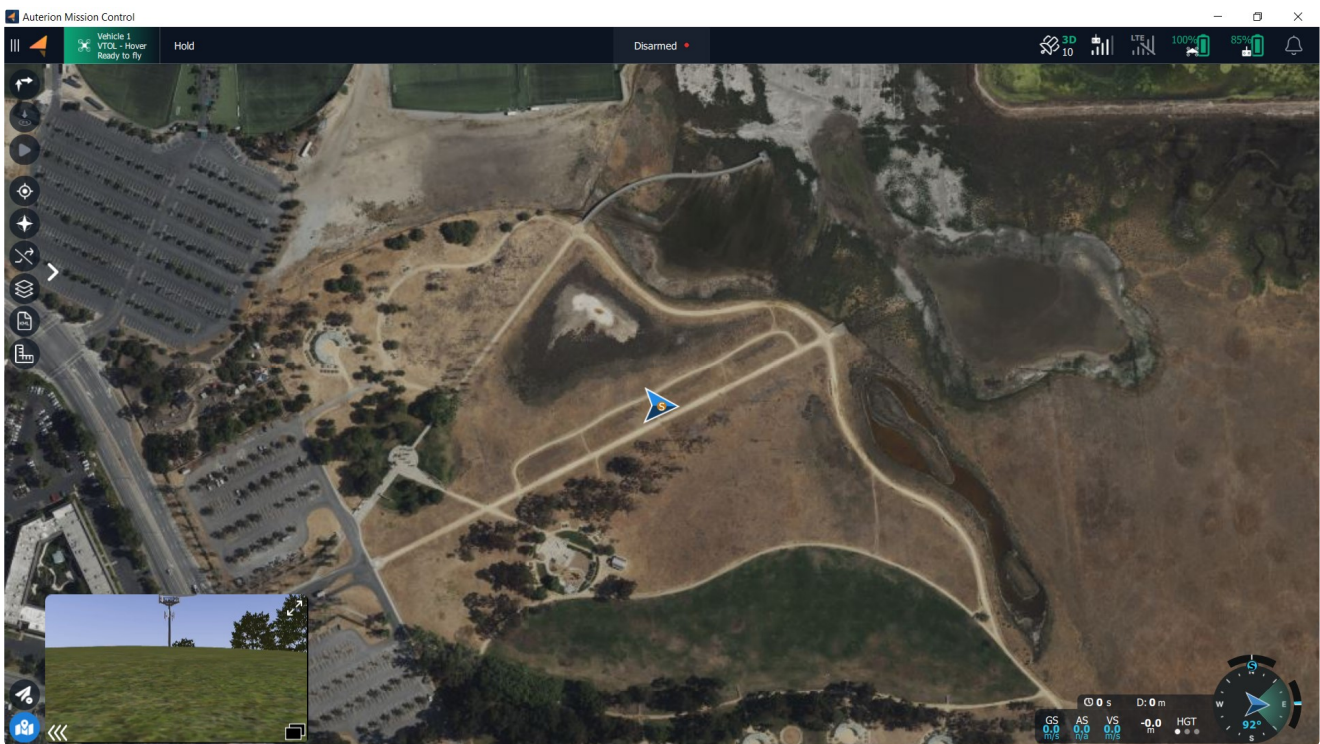

Auterion Mission Control offers two main views. In the Fly View, you execute and monitor missions. The Plan View is used to plan autonomous missions for your vehicle. Once the mission is planned and uploaded to the DeltaQuad EVO, you switch to the [Fly View](#) to perform the [Pre-flight checks](#) and execute the mission.



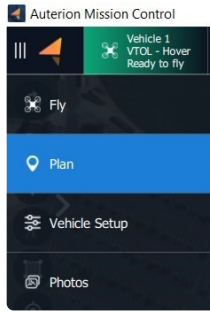

You can switch between the two views by clicking on the Menu Icon .

The application drop-down menu will open. The blue colored tab is the active view. To switch to the other view simply click on the respective tab.



The following two chapters will explain in detail the layout of the [Fly View](#) and the [Plan View](#).

The application menu has four more tabs to choose from.

Tab	View	Description
 Vehicle Setup	Vehicle Setup	Vehicle configuration, including sensor calibration and safety actions.
 Photos	Photos	View photos and videos downloaded from the vehicle.
 User Account	User Account	Login or logout of Auterion account. This associates pilot with flights on <i>Auterion Suite</i> .
 Settings	Settings	Application Settings

Normal and Advanced mode

There are two modes Auterion Mission Control can run in. The Normal mode and the Advanced mode.

When tapping five times on the Menu icon  a pop-up window will appear with the option to switch to Advanced mode.

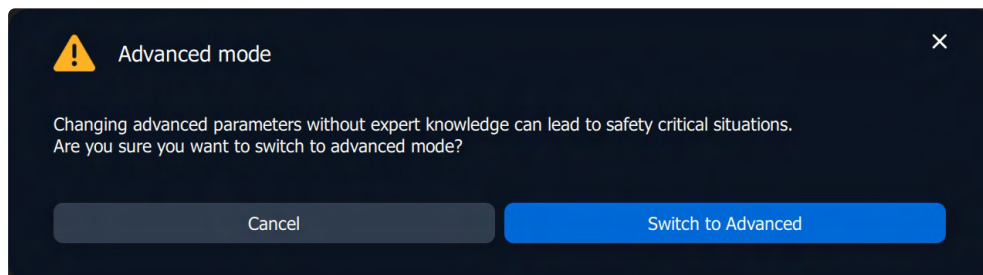

When the Advanced mode is enabled the Menu icon  is black.

When the Normal mode is enabled the Menu icon  is orange.

In Advanced mode, more options are available. For example, the Analyze tab  Analyze in the Auterion Mission Control menu will become available, or the VTOL Transition distance can only be changed when operating in Advanced mode.

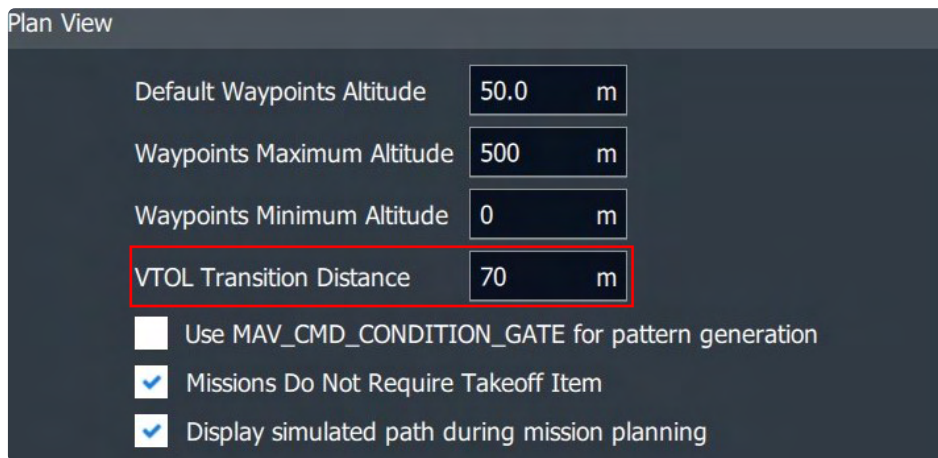

When Advanced mode is enabled tapping five times on the Menu icon  will open a pop-up window with the option to switch to Normal mode.

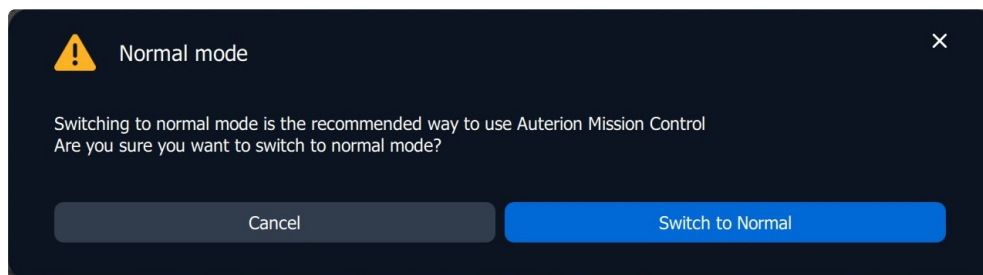

Fly View

In the Fly View, missions are executed and monitored. The operator has two layouts available. By default, the map is the primary view and the video feed is the secondary view. You can change the layout by clicking the small window in the lower left corner.

Primary view - map, secondary view - video feed:



Primary view - video feed, secondary view - map view:

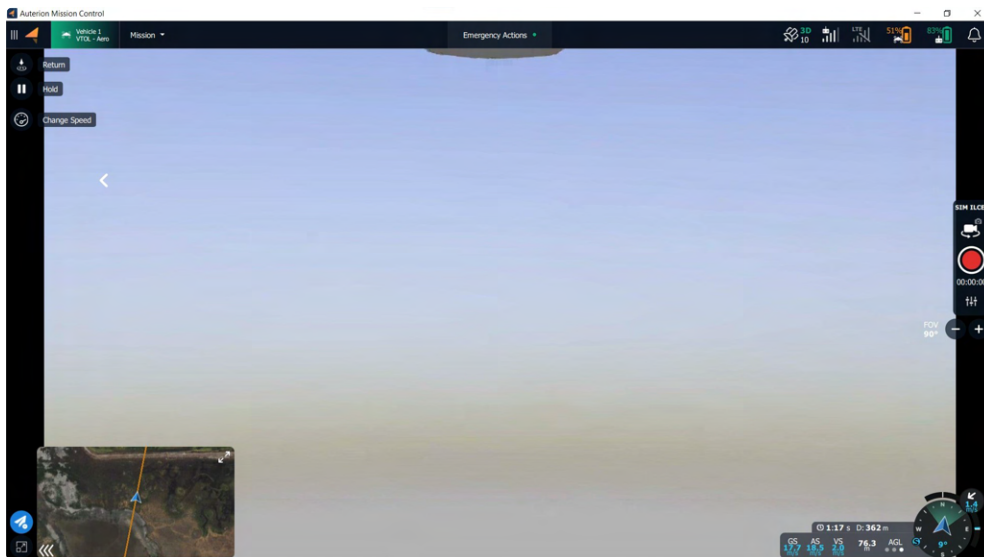

- i** The smaller secondary window in the lower left corner can be resized by clicking the two arrows in the upper right corner. Simply drag the window to the desired size.

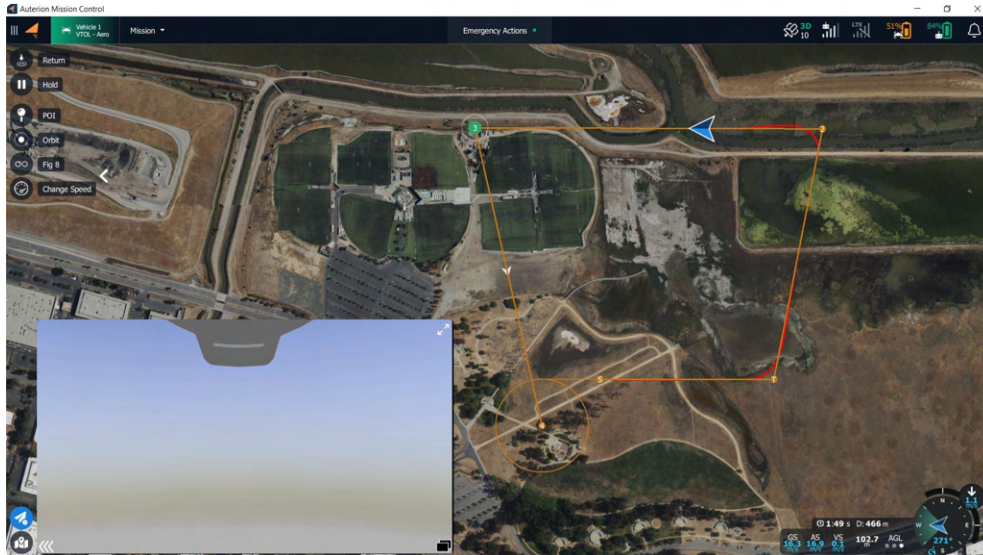

The following is a complete list of actions that can be taken within the secondary window.

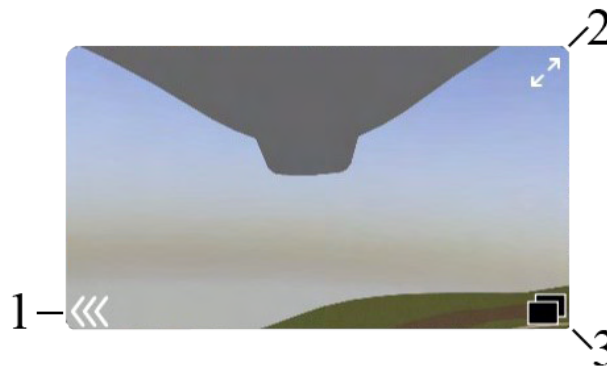

1. Minimize or maximize the window
2. Adjust the size of the window
3. Detach the window from the lower left corner

i Depending on whether the map or the video feed is the primary view, the available tools, and functions change. When the map is the primary view, all Fly Tools are available. When the video feed is the primary view the payload controls are available.

Map is the primary view:

All Fly Tools are available

Video is the primary view:

Payload controls are available

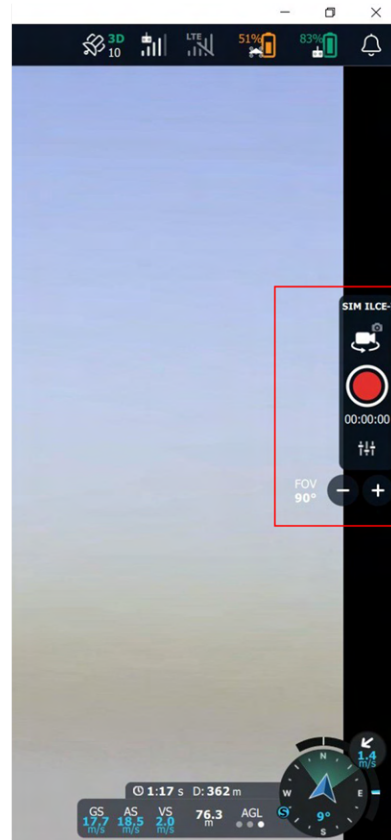
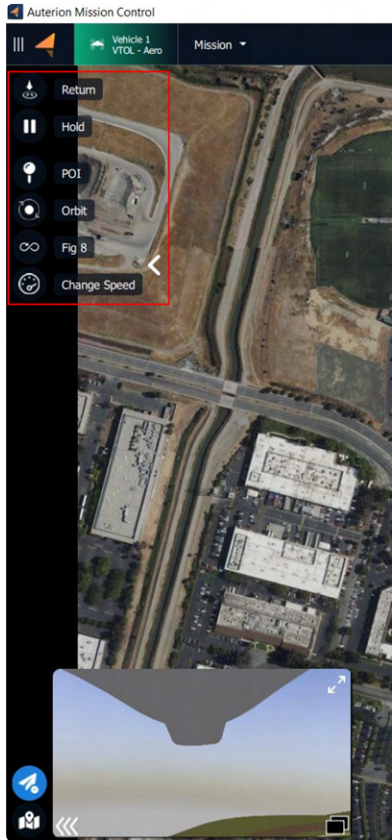

i The available payload controls depend on the mounted payload. The payload controls will be discussed separately in the dedicated section for each available payload.

Fly View elements

The following list describes all elements of the Fly View.

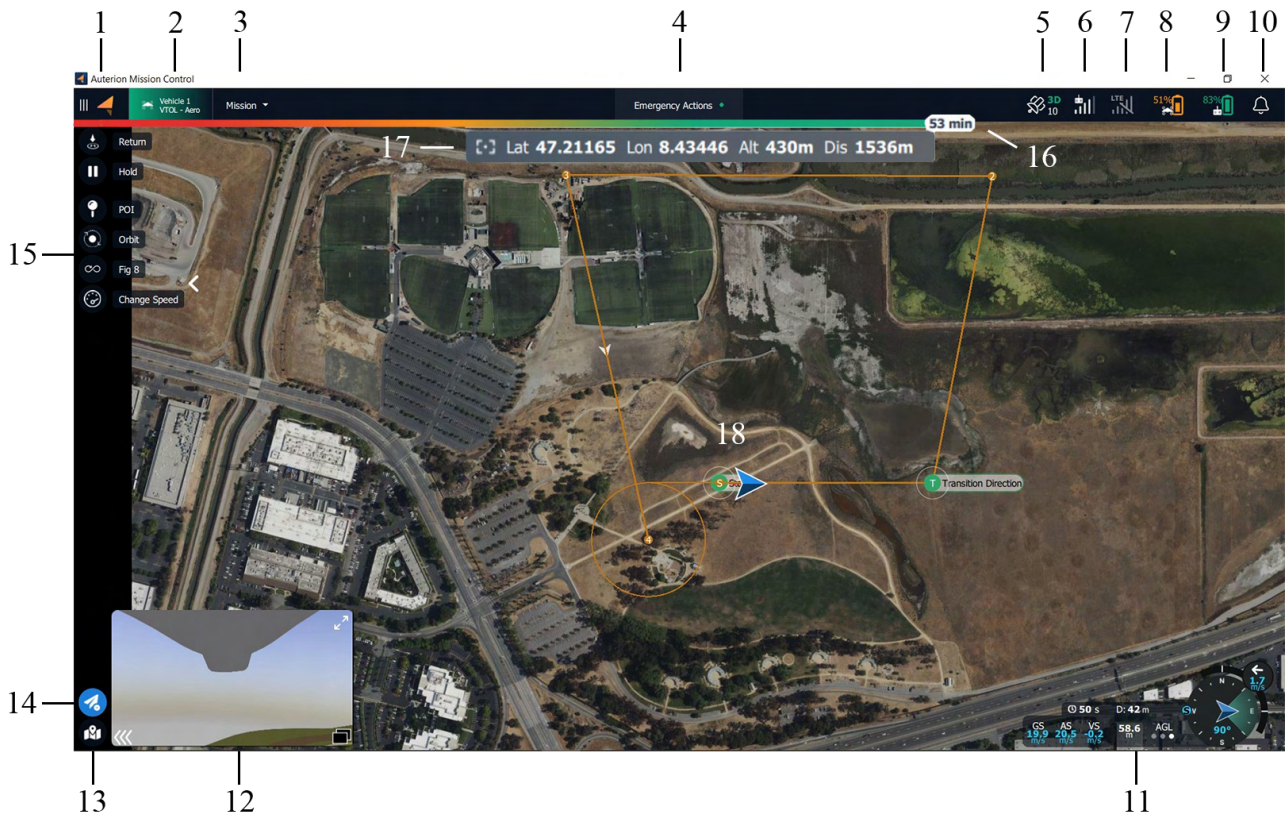

1. AMC Menu
2. Vehicle Status and Selector
3. Flight Mode
4. Emergency Actions and Arm Status
5. GPS Status
6. Radio Signal Strength
7. LTE Status and Signal Strength
8. Battery Status of the Vehicle
9. Battery Status of the Ground Control Station
10. Notifications Tab
11. Telemetry and Compass
12. Video feed
13. Map Tools
14. Flight Tools
15. Fly View Tools
16. Estimated flight Time Remaining
17. Additional information depending on mounted payload
18. Map, Mission Items, Smart Actions, Vehicle Location (blue arrow), and Vehicle Track (red trail)

Connection Manager

When installing Auterion Mission Control on a separate device such as a laptop or desktop pc, by default the Connection Manager  will be available in the top bar of Auterion Mission Control.



The DeltaQuad EVO does not make use of the Connection Manager. In Settings>General>Miscellaneous this option can be disabled.

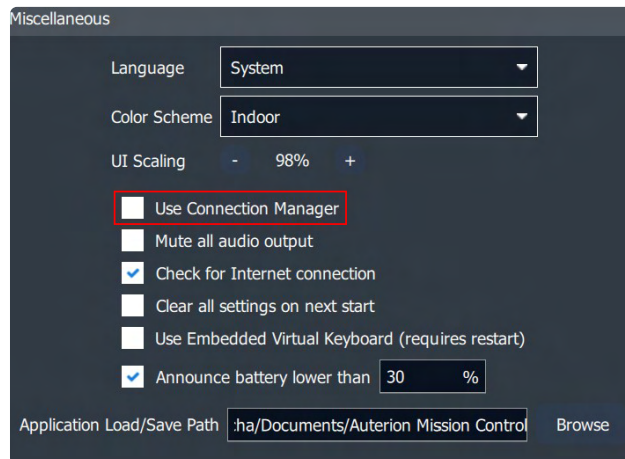

Telemetry Panel

The Telemetry Panel is located in the lower right corner of the screen. It is available in both layouts when the map is the primary view and when the video is the primary view.

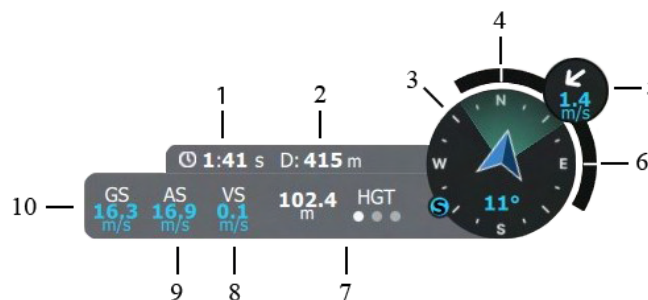





1. Time since armed (approximate flight time)
2. Distance between vehicle and ground station
3. Compass (incl. vehicle heading, camera field of view, direction towards the Ground Control Station)
4. Roll Index
5. Wind direction and wind speed
6. Pitch Index
7. Altitude display - tap the letters above the three dots to change to the different altitude measurements:

Symbol	Meaning
HGT	Height above takeoff
MSL	Altitude above Mean Sea Level
AGL	Altitude above Ground Level

- 8. Vertical speed
- 9. Calibrated airspeed
- 10. Ground speed/horizontal speed







Fly View Tools

The following Fly View Tools are available on the left side of the screen when the map is primary.

Symbol	Command	Action
	Takeoff	Command for takeoff - altitude, transition direction, loiter for takeoff, and approach sectors can be set.
	Return	Return to the start location - the vehicle will return with the approach feat if at least one green sector is set. If no green sector is available the planned landing pattern will be used.
	Mission	Starts or resumes the planned mission.
	Hold	Pauses the mission or any action. The vehicle will loiter at its current location.
	Approach	Approach sector and Safe Areas can be modified.

Flight Tools

Clicking the Flight Tools button  in the lower-left corner of the screen will open an extra set of commands for controlling the vehicle. When the button is blue it is active and the extra set of commands will be visible. When the button is grey it is inactive and the extra commands will be hidden.

Symbol	Command	Action
	POI	Depending on the payload a Point of Interest can be set. The camera will follow the specified location while the vehicle will remain on its flight path. The Point of Interest can be removed by clicking on Disable POI  .
	Orbit	Sets an Orbit with selectable altitude, radius, and loiter direction.
	Figure of 8	Sets a figure of 8 with selectable figure size, and altitude. The figure of 8 automatically realigns when a POI is set to keep the POI in the field of view.
	Change Airspeed	Enables the operator to change airspeed. When clicked the Airspeed slider appears on the right side of the screen. Values between 14m/s to 25m/s available.
	Set Altitude	The altitude of the vehicle can be changed.





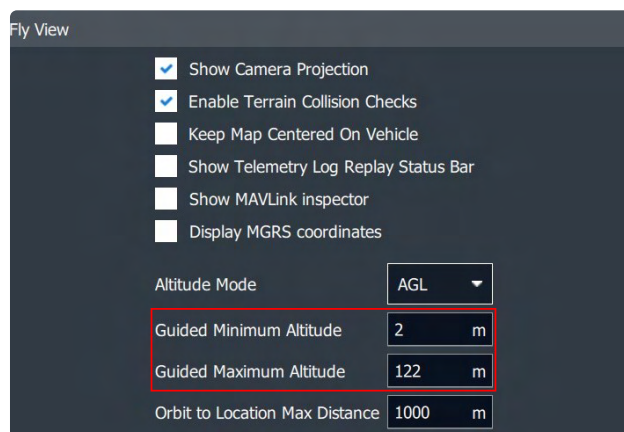

When using the Set Altitude command  the Altitude Slider will be presented with a fixed Minimum and Maximum Altitude. The operator can choose an altitude between these values.

These values can be changed in Settings>General>Fly View.



Map Tools

Clicking the Map Tools button  in the lower-left corner of the screen will open the Map Tools. When the button is blue it is active and the extra set of commands will be visible. When the button is grey it is inactive and the extra commands will be hidden.

Symbol	Command	Action
	Center Map	Centers the map on the vehicle
	Marker	Set markers for situational awareness
	Clear Path	Delete last flightpath to clear the map
	Map Layers	Changes between map layers
	Load KML overly	Import KML file to the map
	Measure	Opens the Measurement Tools

Marker Tool

The Marker Tool  can be used to increase situational awareness. The set markers will be also displayed in the video feed.

When clicking on the Marker Tool button a menu will open.

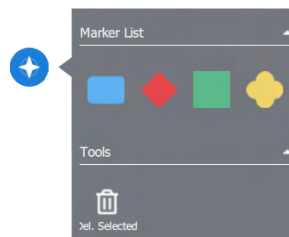

Different Marker Tool Categories can be chosen by color and form. Click on the map to set the marker.

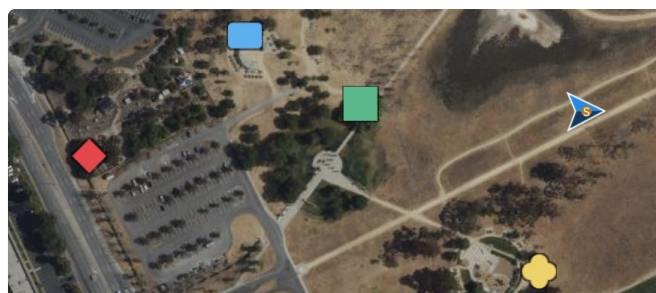

To delete a marker, select it on the map and click on Del. Selected in the Marker Tool menu.

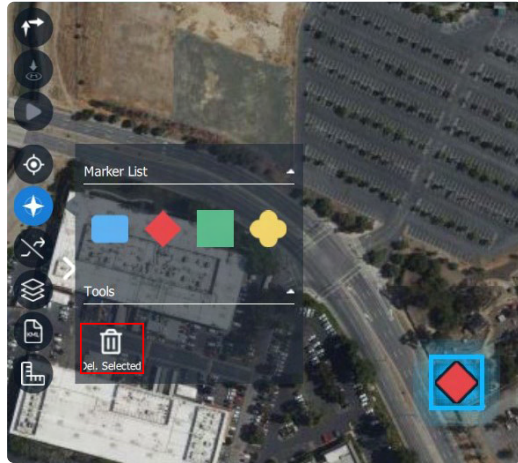

Measurement Tool

The Measurement Tool button  opens a menu.

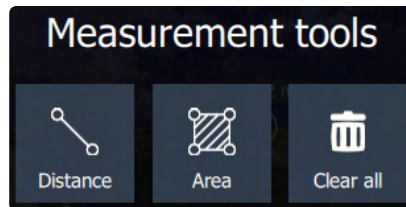

The distance between two points can be measured or the area in the form of a selectable polygon. Clear all will delete all Measurement Tools on the map.

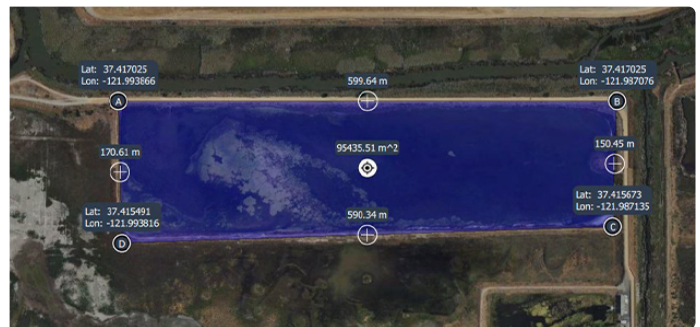
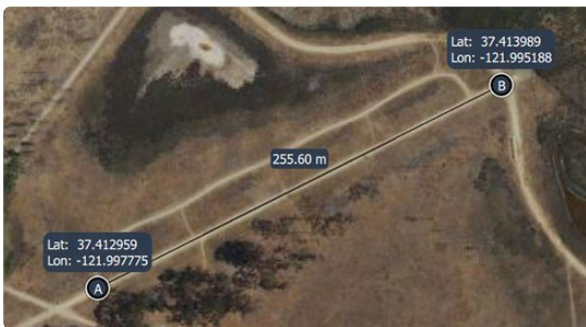

Coordinates can be entered manually.

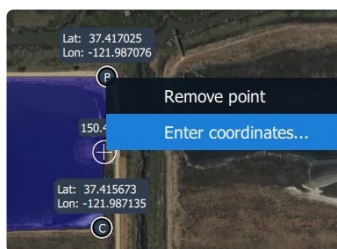

Flight Mode icon

The third item in the upper-left corner of the screen is the Flight Mode icon.



This item displays the vehicle's current flight mode. When clicked the operator can change to the Position flight mode for manual control.

During operation, the Flight Mode icon can display the following modes.

Mode	Description
VTOL Takeoff	Flight mode during takeoff
Mission	Flight mode in which the vehicle executes a planned mission.
Hold	Flight mode when the Hold, Orbit, or Figure of 8 command is given.
Return	Flight mode when executing the Return command.
Land	Flight mode when Landing in the Emergency Actions has been chosen.
Position	Manual flight mode is enabled. The vehicle can be controlled with the right joystick When there is no stick input the vehicle maintains altitude and course.

Plan View

In the Plan View, you can create, edit and save missions, which can be uploaded to the DeltaQuad EVO. To plan a mission the DeltaQuad EVO does not need to be connected to Auterion Mission Control.

When opening Auterion Mission Control by default the Fly View will be selected. To change to the Plan View Click on the Menu icon  in the upper left corner of the screen. A drop-down menu will open. Select the Plan tab.

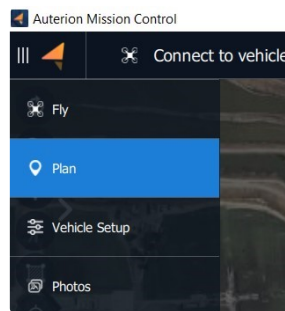

The image below shows a simple mission that starts with a Start and a Transition Direction item. The mission continues to fly through three waypoints which are followed by a Mission End Action.

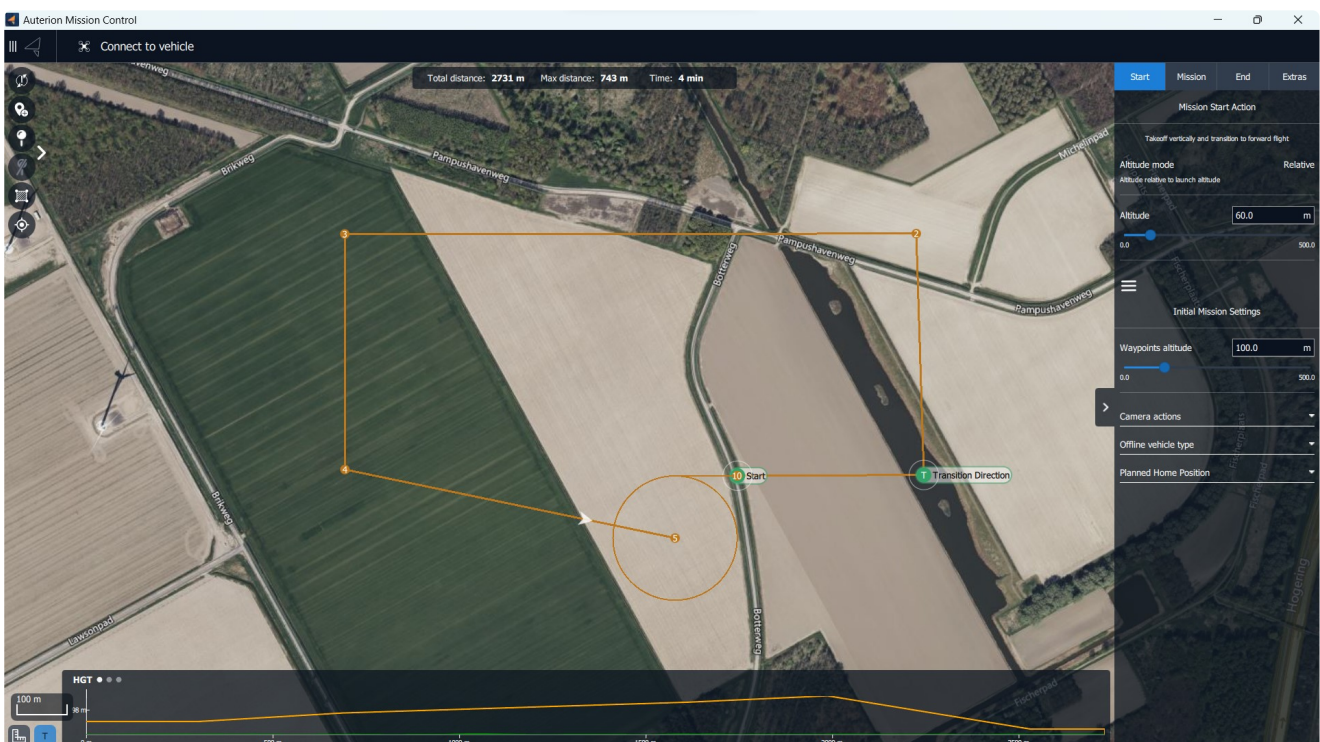

The steps for creating missions are:

1. Change to Plan View.
2. Add commands to the mission and edit as needed.
3. Upload the mission to the vehicle.
4. Change to Fly View and fly your mission.

Plan View elements

The following section describes all elements of the Plan View.

The Top menu bar consists of the same elements as the Fly View.

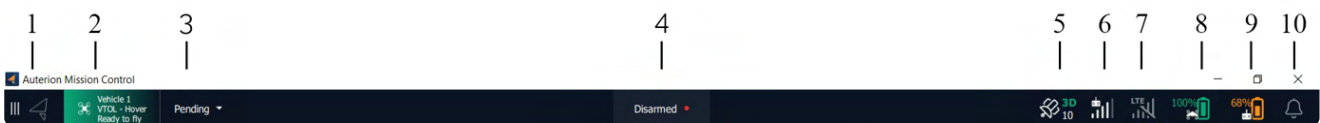

1. AMC Menu
2. Vehicle Status and Selector
3. Flight Mode
4. Emergency Actions and Arm Status
5. GPS Status
6. Radio Signal Strength
7. LTE Status and Signal Strength
8. Battery Status of the Vehicle
9. Battery Status of the Ground Control Station
10. Notifications Tab

Plan Tools

On the left side of the screen, the Plan Tools are located. The Plan Tools provide tools for working with plans, including adding waypoints, inserting survey patterns, saving, loading, uploading, and downloading plans. Some of the options are only displayed when working on a particular type of plan.

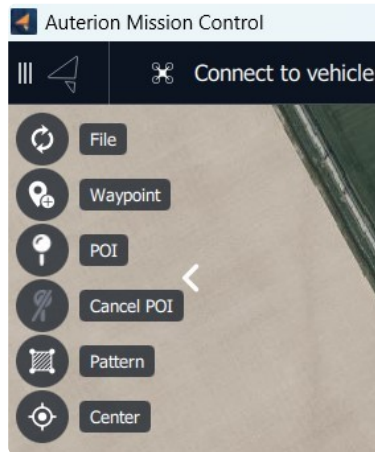

File and Sync Tool

The File Tool  provides options to create a new mission plan, load and save plans on the Ground Control Station, and upload, download, or clear the plan on the vehicle.

 Only valid options are enabled (e.g. Download is grayed out if there is no mission on the vehicle).

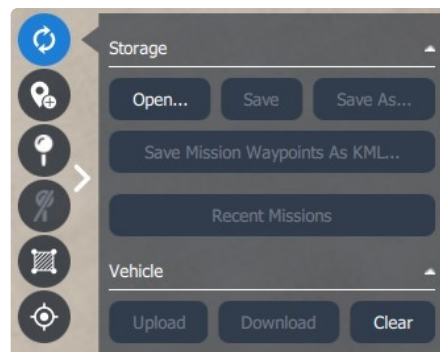

Storage

Option	Description
Open...	Open a plan file from storage, or clear the current mission in the Ground Control Station. The plan the vehicle is not affected.
Save	Save previously opened or saved plans under the same name. AMC prompts to Save as if the file is new.
Save as...	Save the current plan under a new name.
Save Mission Waypoints as KML ...	Save the current mission as a KML file. KML files are used by Google Earth.
Recent Missions	Open a menu of recently created or loaded mission plans.

Vehicle

Option	Description
Upload	Upload the mission plan to the vehicle. Existing plans on the vehicle are cleared.
Download	Download the current plan from the vehicle. The current plan on the ground station is cleared.
Clear	Clear the mission plan on the vehicle and AMC. Disabled if no vehicle is connected.

Waypoint Tool

Select the Waypoint Tool  to enable adding new waypoints to the map.

Point Of Interest (POI) Tool

Select the Point Of Interest (POI) Tool  to enable adding a point of interest on the map. The camera gimbal will point toward the last POI created.

Cancel POI Tool

Select the Cancel POI Tool  to cancel the last point of interest on the map.

Pattern Tool

Select the Pattern Tool  to add or load a survey or corridor pattern. Additionally, a KML/SHP file can be loaded.

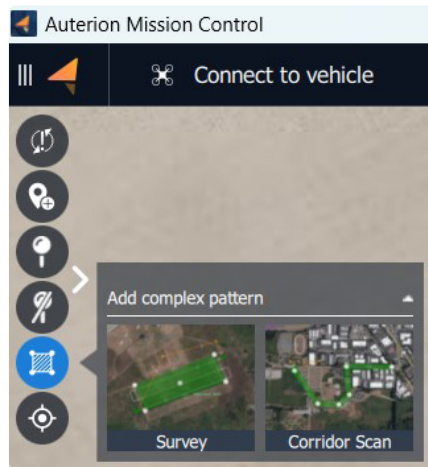

Center Tool

The Center Tool  gives multiple options to center the map on a mission, home, vehicle, all items, or a specified location.

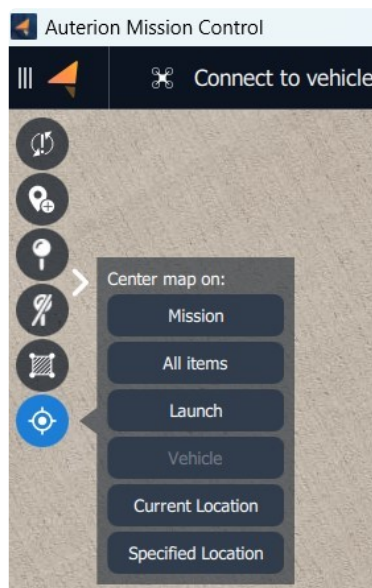

Option	Description
Mission	Center or zoom the map to include all mission waypoints.
All items	Center or zoom the map to include all plan items (missions, geofences, rally points)
Launch	Center the map at the point where the vehicle arrives and takes off.
Vehicle	Center the map on the vehicle location. Disabled if no vehicle is connected.
Current Location	Center the map on the location of the Ground Control Station (AMC). Disabled if Ground Control Station does not have location or GPS.
Specified Location	Center the map on a specified location. Enter geographic, UTM, or MGRS position information, to make it the new map center.

Mission Statistics

Under the top menu bar, the mission statistics are located.

Total distance: **0 m** Max distance: **0 m** Time: **0 min**

The mission statistics give information about the total mission distance, the maximum telemetry distance, and the total mission time.

Upload Button

The Upload Button uploads the current mission, geofence, and rally points to the vehicle. The button has two states.

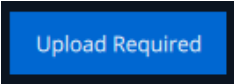
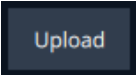
Symbol	Name	Text
	Upload Required	The mission plan has been changed since the last upload. A new upload is required.
	Upload	The mission plan has not been changed and the vehicle has the latest version stored. It may be re-uploaded anyway.

Plan Item Selector

At the top right of the screen, the Plan Item Selector is located.

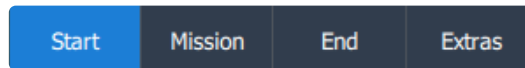

The Plan Item Selector sets the part of the mission plan which is being edited.

Plan Item Editors

The Plan Item Editors are displayed below the Plan Item Selector. Different item editors are displayed for each part of the mission plan:

- **Start:** In this tab, you can edit the values of the Mission Start Action which consists of the Start or takeoff item and the Transition Direction item.
- **Missions:** The mission tab shows a list of editors, one for each item in the mission (waypoint, commands, etc.)
- **End:** In this tab, you can edit the values of the Mission End Action. The Mission End Action can be either a landing pattern that consists of the Orbit and the Land item or only an Orbit item.
- **Extras:** In this tab, you can add or remove GeoFence definitions, and select the current GeoFence region for editing on the map.

Measurement Tool

In the lower-left corner, the Measurement Tool  is located. When clicking on it a menu will show.

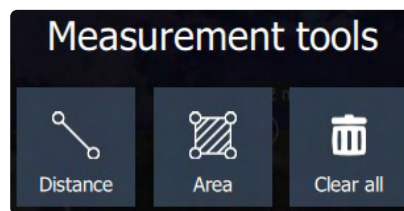

The distance between two points can be measured or the area in the form of a selectable polygon. Clear all will delete all Measurement Tools on the map.

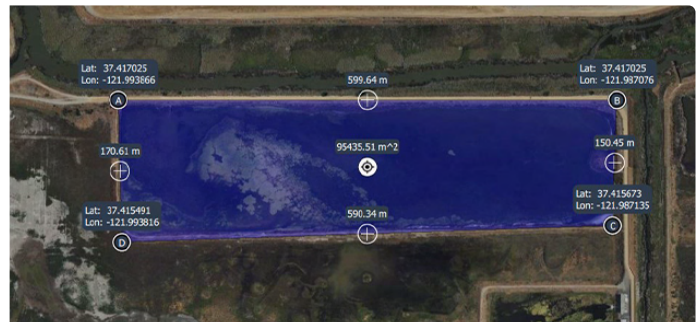

Coordinates can be entered manually.

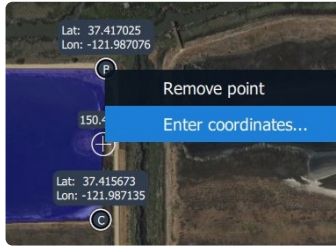

Terrain Altitude Indicator

At the bottom of the screen, the Terrain Altitude Indicator is located.

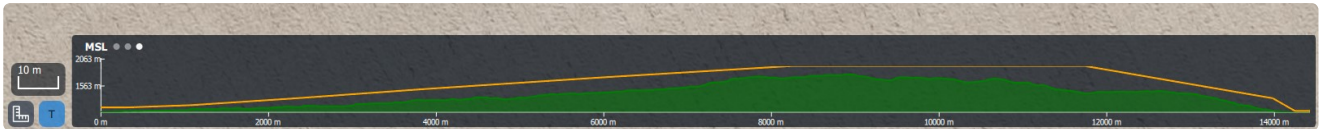

The Terrain Altitude Indicator is used to verify that the mission is set above ground level! It can be toggled visible or hidden using the **T** button next to the Measurement Tool.

⚠ A red line indicates a ground collision!

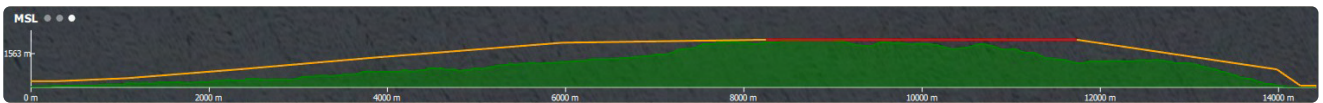

In the upper left corner of the Terrain Altitude Indicator, you can select between three different altitude measurements.

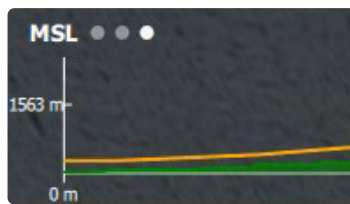

Simply tap the letters next to the three dots to change to the different altitude measurements:

Symbol	Meaning
HGT	Height above takeoff
MSL	Altitude above Mean Sea Level
AGL	Altitude above Ground Level

Scale Marker

Above the Measurement Tool and the Toggle button, the Scale Marker is located.

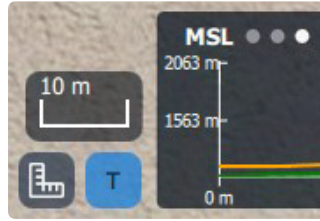

It indicates the scale of the map depending on how much the map is zoomed in or zoomed out.

To use the zoom function the mouse wheel can be used or two fingers when operating on a touchscreen.

Planning a mission

The DeltaQuad EVO has been designed to fly autonomously, this is achieved by planning and executing missions. Missions are set through the Ground Control Station. They can be created and sent to the vehicle directly, loaded from an existing mission plan, or saved to a mission plan. This section covers the basics of planning a mission for the DeltaQuad EVO.

The operator can plan a takeoff and landing from the Fly View by selecting sectors that are free of obstacles at the approach altitude.

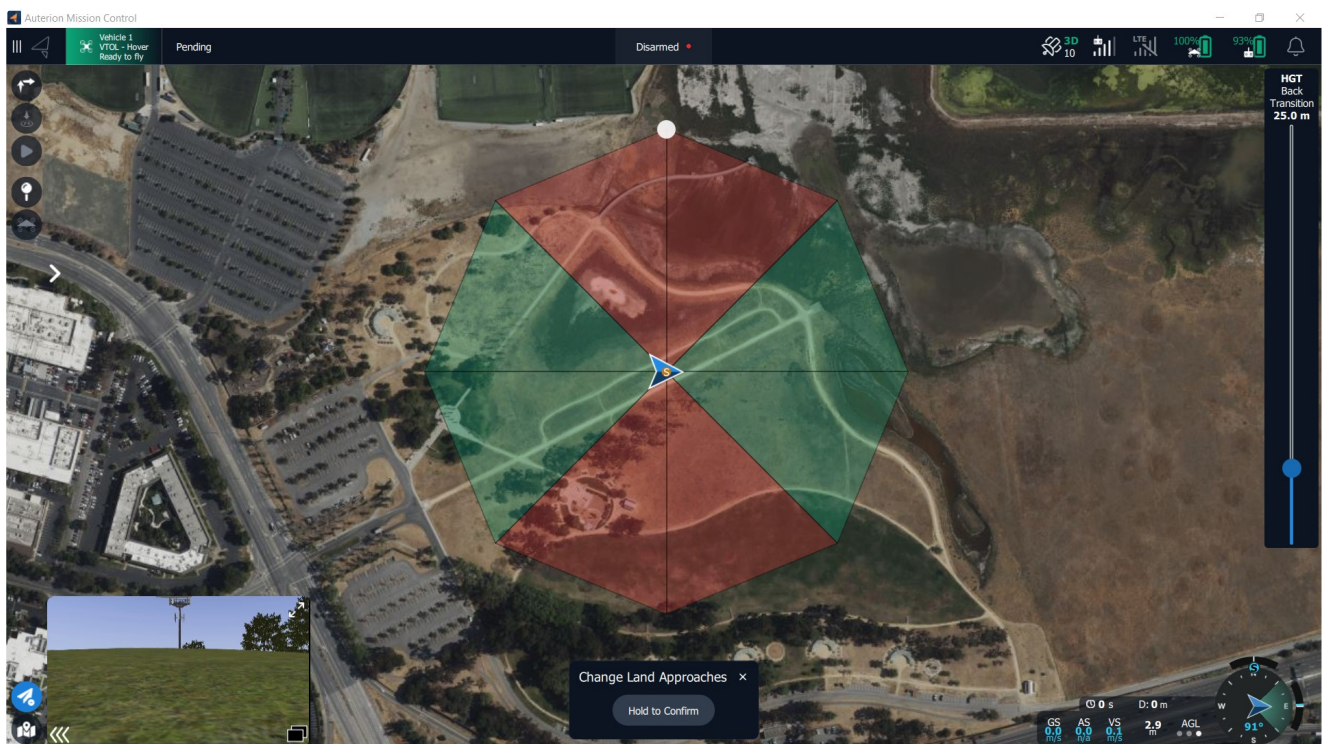

The DeltaQuad will take off and transition to aerodynamic mode into a set direction and orbit until new commands are given.

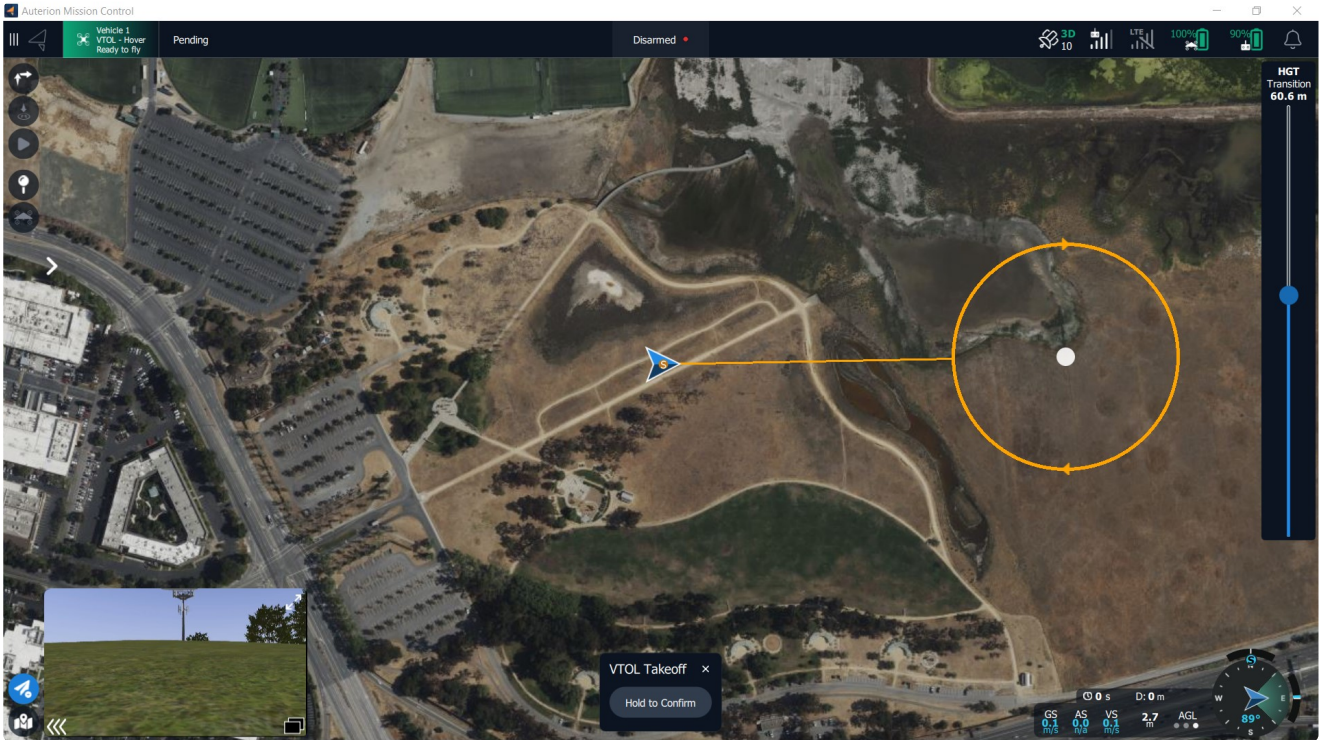

How to take off and land using Fly View will be discussed thoroughly in a later section of this manual.

- i** In certain situations where launch and landing sites pose significant restrictions and obstacles, utilizing the Takeoff and Approach functionalities in Fly View becomes impractical. In such instances, it is advisable to employ the Plan View for comprehensive mission planning.

Preparing a mission plan

Before the mission plan can be created, the following steps should be taken to ensure safe execution:

1. A mission plan should only be executed after a thorough inspection of the entire mission on site. All altitude differences and obstacles should be known and taken into account.
2. Missions must be allowed to be executed in accordance with local laws and regulations.
3. The mission path must be free of obstructions for at least 200 meters in each horizontal direction.
4. During fixed-wing flight (Aerodynamic mode) the vehicle should stay 50m above ground level, near the end of the mission, to reduce landing energy consumed, an altitude of 25m above ground is recommended.
5. For maximum endurance a takeoff altitude can be set to 25m, however, to ensure the safety systems can function properly, the takeoff altitude should be at a minimum of 60 meters above ground level.
6. The takeoff and land sites must consist of a level, flat surface that is free of obstructions for at least 5x5 meters.
7. The takeoff altitude should be set high enough for the vehicle to be able to perform a transition in any direction.
8. The weather conditions must fall within the maximum allowed conditions.
9. Both the front and back transition paths must be planned in such a way that the vehicle is pointing with its nose toward the wind while performing the transition.
10. The intended mission should not consume more than 85% of the total energy available.
11. At any point in the mission, the vehicle must be able to return to its takeoff point in a straight line at its current altitude.
12. At any point in the mission, the vehicle must be able to initiate an unscheduled landing without causing damage to itself or its environment.

Best practices and tips

- A vertical takeoff or landing consumes significantly more energy than a fixed-wing flight. For maximum efficiency, an altitude between 25 and 35 meters is recommended for landing. A takeoff altitude should be at a minimum of 60 meters for all safety systems to function.
- The altitude of the "Planned Home Position" defines the expected touch-down altitude.

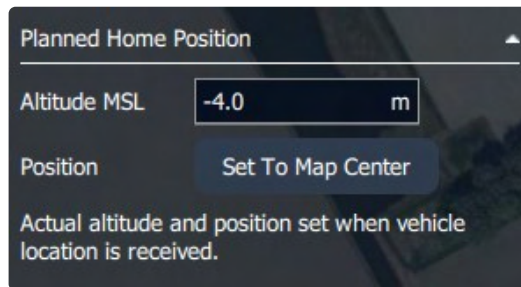

- The back transition from fixed-wing flight (Aerodynamic mode) to multirotor flight (Hover mode) is performed at the altitude set in the "Orbit point" of the Mission End Action command.

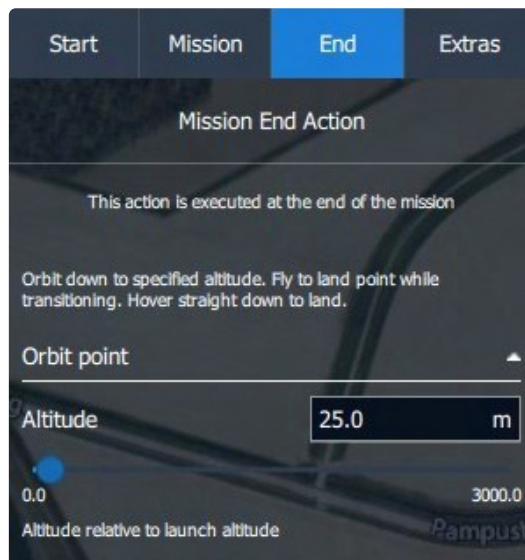

- Most wind forecasts are based on ground-level wind. Even 10 meters above the ground the wind can be significantly stronger.
- During the transition phase of the "Transition Direction" item, the vehicle has limited navigational abilities and could drift from its intended direction. The transition should therefore always be performed at an altitude where it is safe for the vehicle to perform the transition in any direction.

Mission Start Action

Takeoff in Hover mode and transition to Aerodynamic mode.

Before creating a new mission plan make sure that there are no items such as waypoint commands on the map.

1. First, enter the Plan view by selecting the Plan tab from the AMC menu.

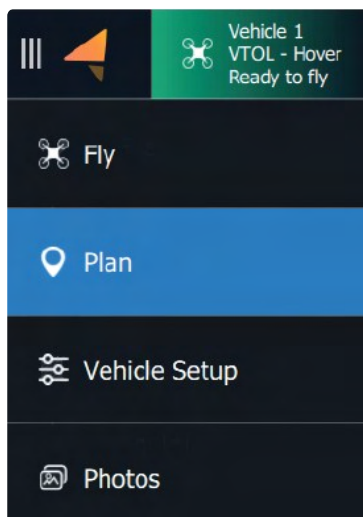

You can clear all waypoints from AMC and the vehicle by selecting the File Tool from the Plan Tools. Choose the clear option.

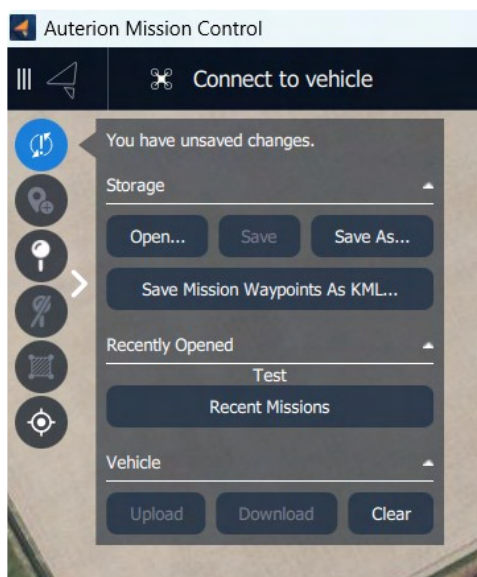

2. When selecting the Start tab the option Add VTOL Takeoff is available.

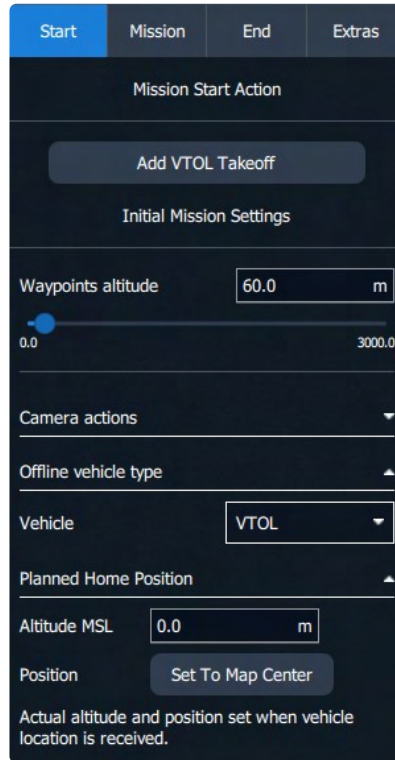

3. Click on the map to specify the start location **S Start** where the vehicle will initiate its takeoff. If the vehicle is currently connected, this location will automatically default to the vehicle's current position.
4. Adjust the Transition Direction icon **T Transition Direction** displayed on the map. This action determines the transition direction for the vehicle, indicating how it will transition from Hover mode to Aerodynamic mode before proceeding to the next mission item. It is important to set the transition direction against the wind, ensuring that the vehicle is also facing the wind. The default distance between the Start item and the Transition Direction item is set to 70m and can be left at that value.

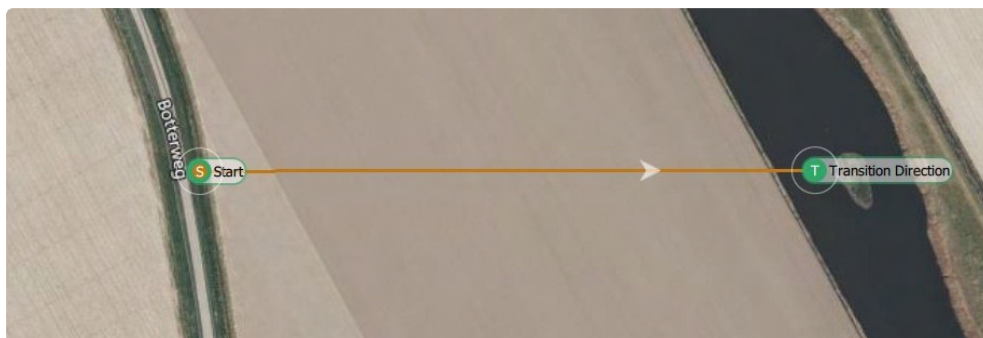

5. Set the VTOL Takeoff altitude in the Plan Item Editor. This is the altitude at which the vehicle transitions from Hover mode to Aerodynamic mode.

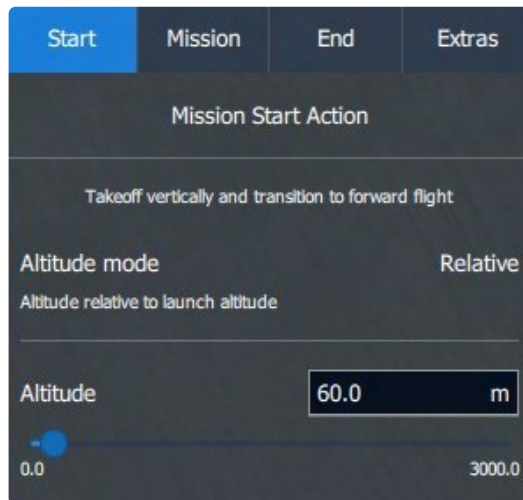

6. We recommend a minimum VTOL Takeoff altitude of 60m for all safety features to function properly. Always make sure to set an altitude that surpasses the height of all obstacles present between the Start and Transition Direction waypoints.

i Please be aware that the altitudes of mission items in the Plan View are relative to the launch altitude, rather than Above Ground Level (AGL).

i For maximum endurance, this value can be set as low as 25m. At that altitude, the safety features might not function properly in the event of an emergency.

i In Hover mode, the DeltaQuad EVO uses up to 12 times more energy compared to the Aerodynamic mode (Fixed-wing mode). We recommend setting the VTOL Takeoff altitude not higher than 100m as this will have an impact on the total flight time. As a rule of thumb, every additional minute ascending in Hover mode will take off 10km from the total mission length. Every extra minute of descending in Hover mode will take off 7km of the total mission length.

7. In the Initial Mission Settings, the default Waypoints altitude can be set.

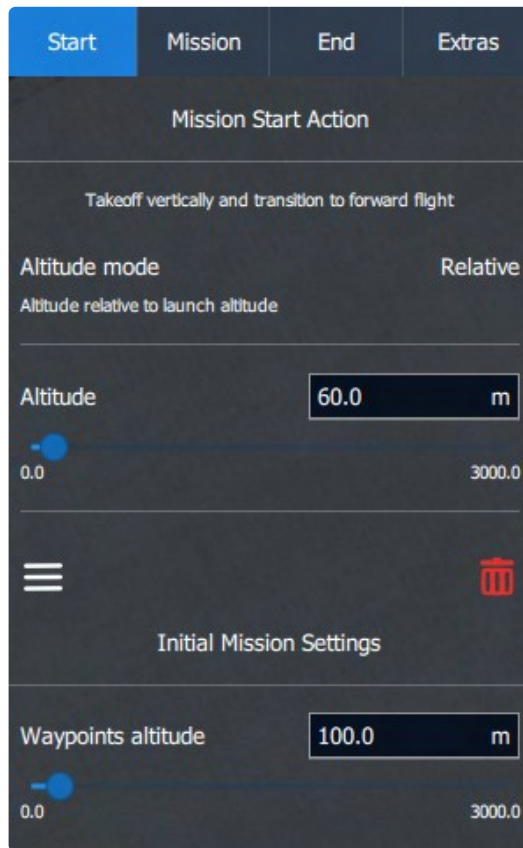

This value can be changed for each individual waypoint in the Mission tab. The default value can be set in the application settings of AMC when the [Advanced Mode](#) is enabled. Settings > General > Plan View

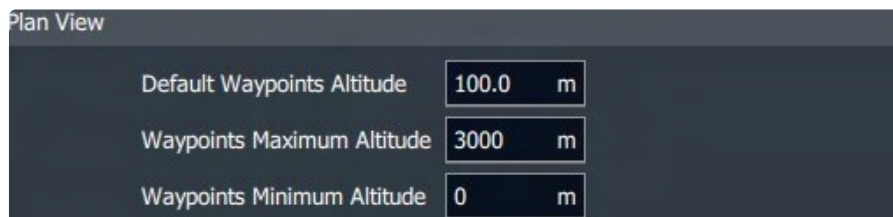

i The vehicle has been designed to transition in the direction it was when positioned on the ground. This allows the operator to perform upwind transitions, regardless of the mission plan. During the transition phase, the vehicle may travel as much as 300 meters. The mission plan should account for this.

i During the transition phase, the vehicle's heading may change due to wind influence. The mission plan should account for this.

Set intermediate waypoints

The DeltaQuad EVO will proceed to these waypoints, continuing in Aerodynamic mode.

1. To plan mission items such as regular waypoints select the Waypoint Tool  from the Plan Tools on the left side of the screen.

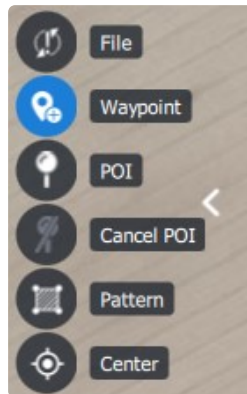

2. Click anywhere on the map to designate a location for the waypoint.



3. After placing the waypoint on the map, the Mission tab in the Plan Item Selector on the right side of the screen will open.

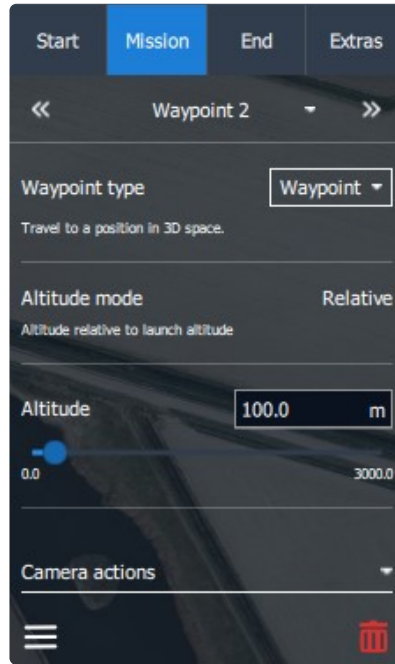

Plan View mission items

4. Choose and set up the desired mission item from the Waypoint type tab.

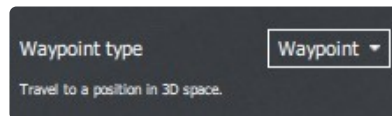

When AMC is used in [Normal Mode](#) three options are available.

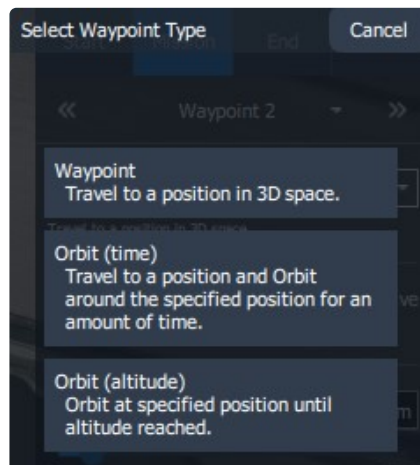

Waypoint type - Waypoint

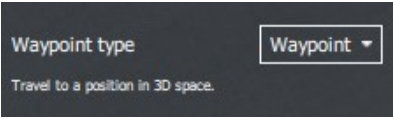
Waypoint type	Action
	<p>The vehicle flies toward the location and altitude specified by the user. Once it arrives, it will proceed to the next mission item. If there are no further mission items following the Waypoint, the vehicle orbits at the Waypoint's location.</p>

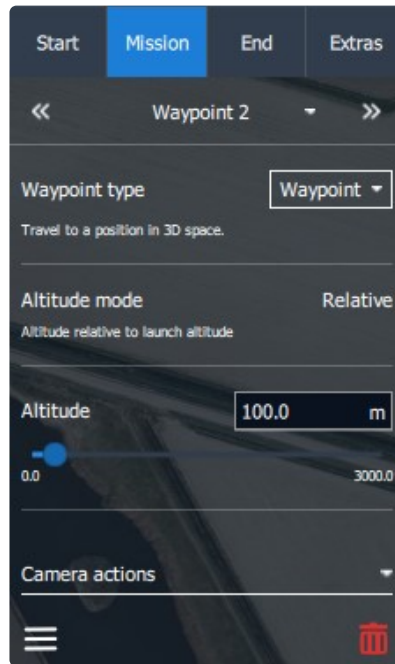

The Altitude mode is the altitude above the launch elevation.

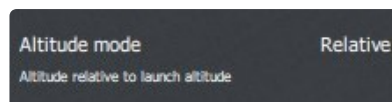

Set the altitude for the waypoint with the altitude slider.

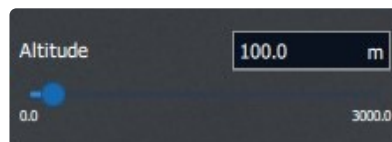

The default range can be changed in the Application Settings. Settings>General>Plan View>Waypoints Maximum Altitude

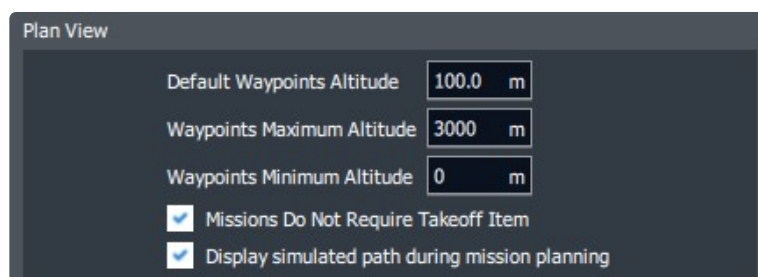

i When changing the altitude of a waypoint, the next waypoint's altitude is automatically set to that value.

Waypoint type - Orbit (time)

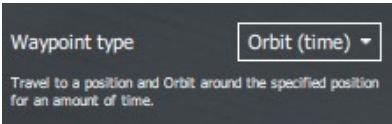
Waypoint type	Action
	The vehicle flies toward the location and altitude specified by the user. Once it arrives, the vehicle will initiate an orbit and continue to circle that position. When the specified Orbit Time elapses, it will proceed to the next mission item.

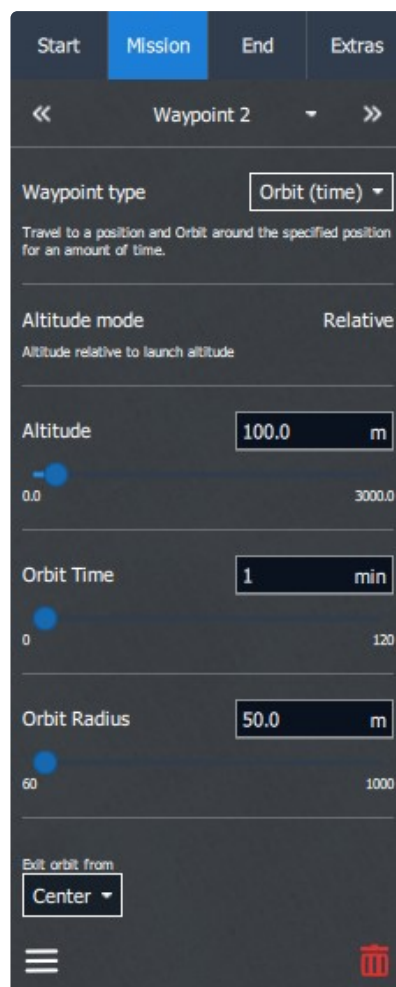

The Altitude mode is the altitude above the launch elevation.

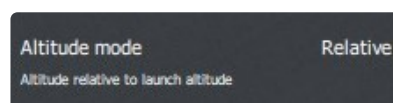

Set the altitude for the waypoint with the altitude slider.



Set the duration of how long the DeltaQuad EVO should orbit at the designated location.

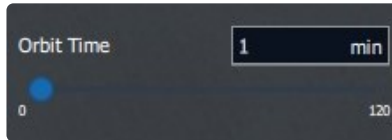

Set the radius of the Orbit. We recommend a minimum radius of 100m. 75m is possible in calm winds.

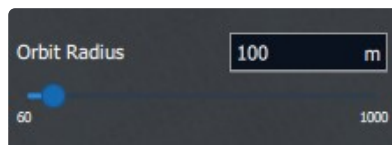

Choose the vehicle's exit point from the Orbit.

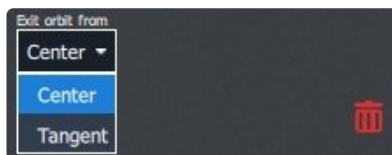

At the bottom of the Mission tab, you can edit the position of the mission item, or delete it.

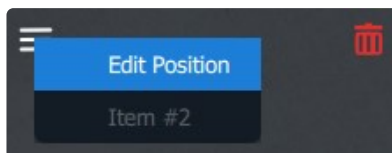

i If the vehicle's altitude differs from the altitude of the next mission item, the vehicle will fly in a straight line toward that mission item.

The vehicle will **not** ascend or descend immediately to the altitude of the next mission item before reaching it.

i If the vehicle can't reach the altitude of the next mission item due to an insufficient climb or descent rate, the vehicle will orbit at the location of the mission item to finish climbing or descending to the item's altitude.

Waypoint type - Orbit (altitude)

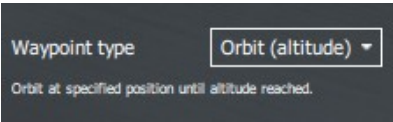
Waypoint type	Action
	<p>The vehicle flies toward the location at its current altitude. Once it arrives, the vehicle will initiate an orbit and start climbing or descending to the user-specified altitude. When the altitude is reached, the vehicle will continue to the next mission item.</p>

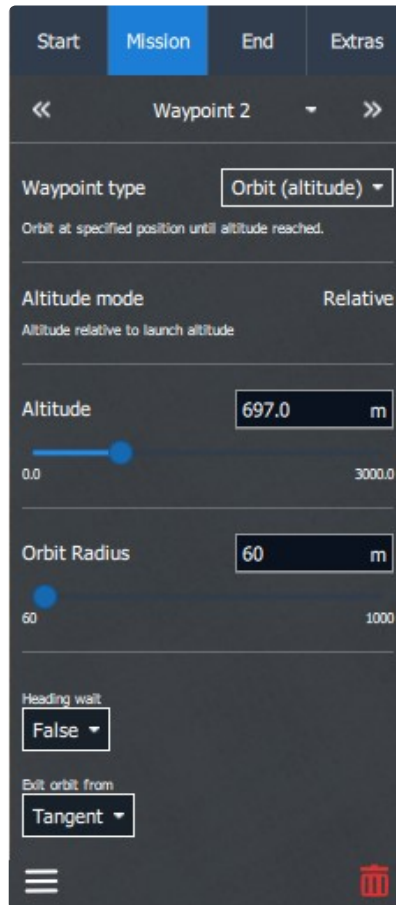

The Altitude mode is the altitude above the launch elevation.

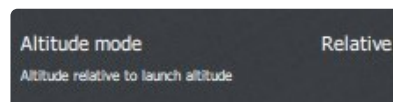

Set the altitude for the waypoint with the altitude slider.

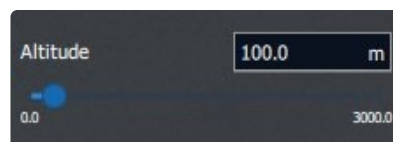

Set the radius of the Orbit. We recommend a minimum radius of 100m. 75m is possible in calm winds.

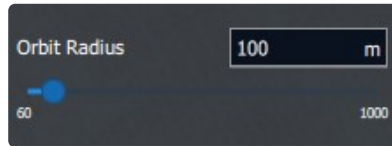

Choose the vehicle's exit point from the Orbit.

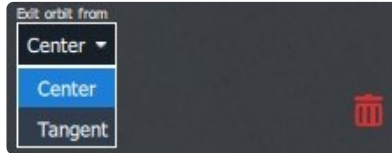

At the bottom of the Mission tab, you can edit the position of the mission item, or delete it.

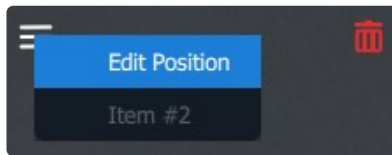

i When using Orbit (altitude), the operator must be especially cautious about terrain collisions.

i Orbit (altitude) is practical for reaching a desired altitude before the flight path continues or when the vehicle's climb or descent rate will not be sufficient to reach the required altitude *en route*.

Mission End Action

The last action of the mission plan. Execute a landing pattern or loiter.

After the waypoints have been placed the Mission End Action has to be planned. When clicking on the End tab within the Plan Item Selector two options are available.

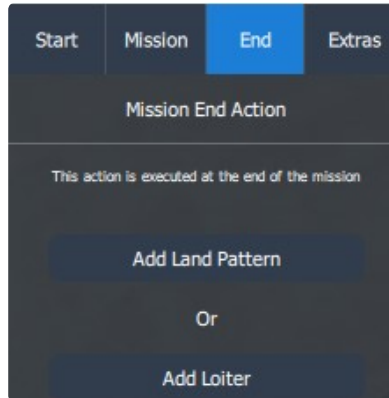

Add Land Pattern

When selecting Add Land Pattern a window will appear with the request to choose a location on the map.

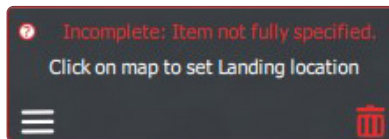

The designated location will be the position of the Land item . AMC will automatically plan an Orbit where the DeltaQuad EVO will descend to the set altitude, approach the Land item, transition to Hover Mode, and land at the designated location.



If the Ground Control Station is connected to the DeltaQuad EVO or the simulator you get a second option to set the Land item to the vehicle location.

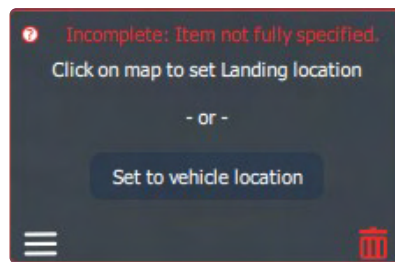

After the Land Pattern is positioned several options will be available in the Mission End Action tab on the right side of the screen.

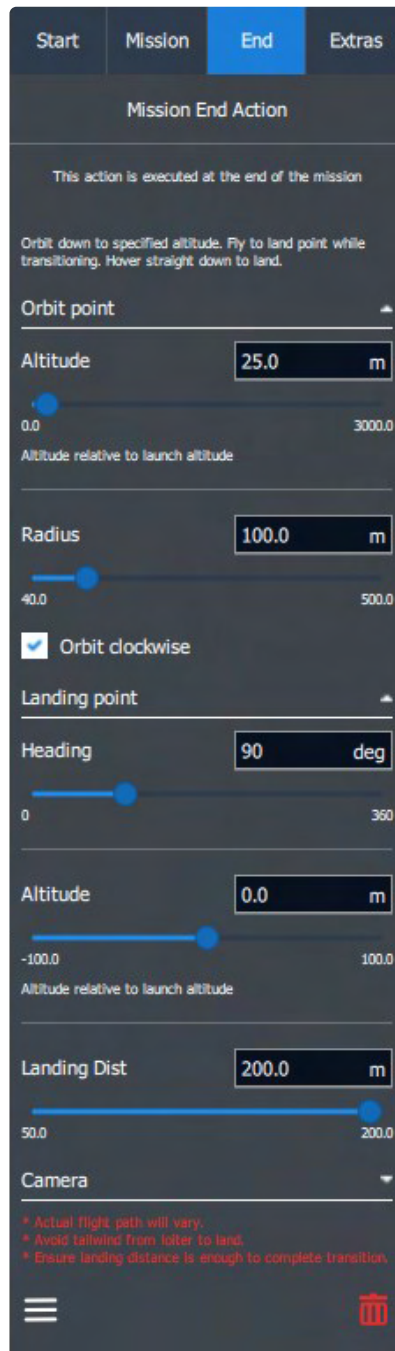

Orbit point

Altitude - The altitude at which the aircraft transitions from Aerodynamic mode to Hover mode prior to landing. The altitude is relative to the launch altitude.

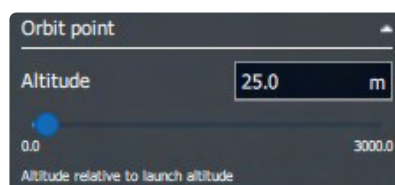

i We recommend an approach altitude between 20m to 30m. This will minimize wind influence during landing and conserve energy.

Radius - The radius of the descent circle. The aircraft will descend in Aerodynamic mode from the mission altitude to the specified altitude mentioned in the Altitude setting above.

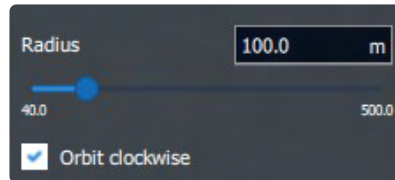

The DeltaQuad EVO will orbit clockwise when the Orbit clockwise box is checked.

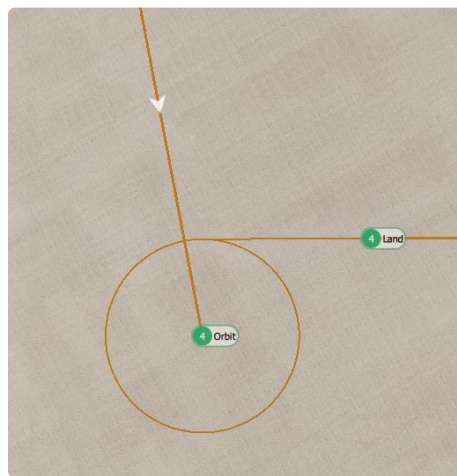

Clockwise Orbit

Disable that option to orbit counter-clockwise. This will change the location of the Orbit.

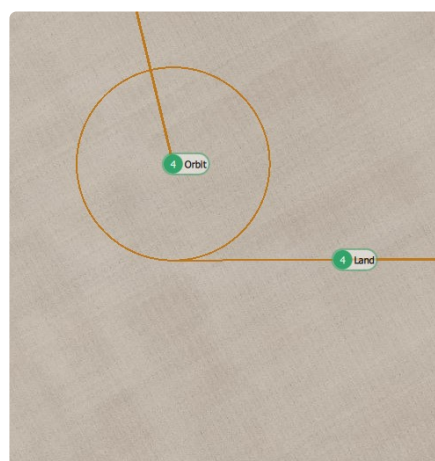

Counter-clockwise Orbit

i We recommend a radius of 100m. In calm winds a radius of 75m is possible.

Landing point

Heading - When placing the Land Pattern it automatically positions the Orbit and Land items in the same direction as the Start and Transition Direction items. As the DeltaQuad EVO needs to launch and transition into the wind it also needs to do the final approach and landing facing into the wind.

The heading can be changed by dragging the Land Pattern items on the map or using the Heading slider.

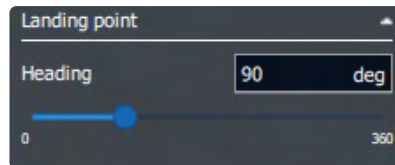

i The DeltaQuad EVO needs to transition to Hover mode and land into the direction of the wind.

Altitude - The altitude of the Landing point is the relative altitude to the Start item where the vehicle is expected to touch down. When landing at the same altitude where the takeoff occurred this can be left at 0. The aircraft will confirm the setting by utilizing its integrated ground distance sensor.

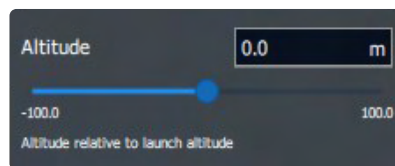

Landing Dist - The distance between the Orbit and the Land item will be automatically set to 50m. You can change this distance by dragging the Land item on the map or by using the slider. Values between 50m and 200m are available.

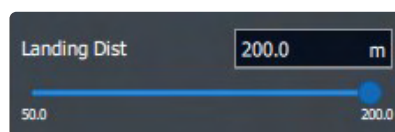

At the bottom of the Mission tab, you can edit the position of the mission item, or delete it.

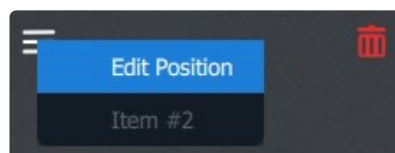

Add Loiter

When choosing Add Loiter from the Mission End Action tab an Orbit waypoint will be placed on the map.

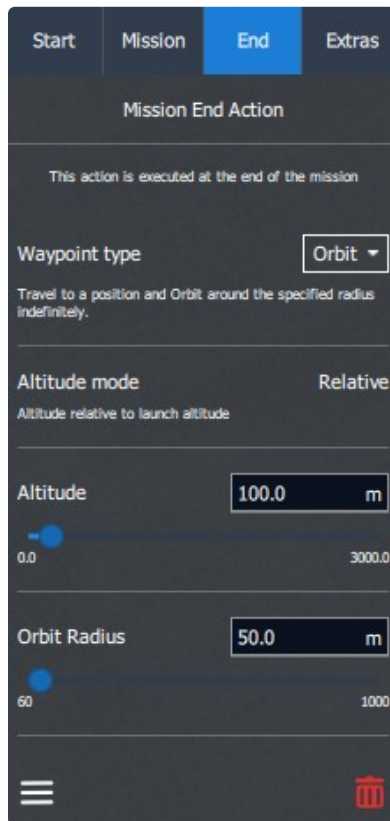

The Waypoint type and other settings can be adjusted as explained in the chapter [Set intermediate waypoints](#).

Pre-flight checks

Mission

- Mission conforms with local laws and regulations.
- The mission was planned in accordance with the guidelines set forth in the Plan section.
- Altitudes verified across terrain height.
- The mission path is free of obstructions for at least 200 meters in each horizontal direction.
- VTOL Takeoff and VTOL Land items were correctly applied.
- The takeoff location is free from obstructions at transition altitude for 500m in every direction.
- Takeoff and land site are clear of obstacles and structures higher than transition altitude.
- The path for takeoff and landing is set so that the vehicle points into the wind.

Airframe

- The vehicle does not exceed the scheduled maintenance or preventive maintenance cycles.
- The airframe conforms with all local rules and regulations and is permitted to fly the intended mission.
- The propellers are mounted in the correct position, orientation, and direction as specified in the Assembly section.

Visual inspection for damage, dirt, and correctly mounted and securely fastened:

- Propellers
- Motors
- Wings
- Servos
- Elevons
- Devices inside the fuselage
- Flight battery

In conditions below 5 degrees celcius

- The landing gear is free from ice, snow or mud. This could cause the landing gear to freeze and prevent deployment.
- The vehicle is launched from a solid surface that is devoid of snow, or mud.
- The pitot tube is free from icing
- The batteries are heated above 10 degrees celcius before takeoff.

Before closing hatch

- When the vehicle sits outside, the hatch must not be closed until the vehicle is ready for takeoff as the components inside could overheat when sitting idle. Exposure to direct sunlight when idle for more than 5 minutes should be avoided.
- Flight battery - Securely positioned, connector fully joined.
- Telemetry - Attached and working.
- The payload sits within the payload bay, is properly connected, and does not exceed 3 kg.
- Components inside the fuselage are securely fastened and cannot move during flight.

After closing hatch

- Hatch secured (closing mechanism pushed down and locked)
- Hatch sits flush with the fuselage
- Wings are properly secured.

Before takeoff

- Weather conditions and mission within [tolerances](#).
- The vehicle is pointing into the wind.
- No warnings on GCS.
- The wing servos are powered (try to move the elevons and feel resistance from the servo).
- The vehicle's current physical orientation matches the heading observed on GCS.
- The flight battery is fully charged.
- The ground equipment has sufficient charge to perform the mission.
- Safety features are set correctly.
- GPS lock is stable with at least 10 registered satellites.
- Mission plan is uploaded
- The takeoff waypoint is active (green)

Executing and monitoring a mission

Before executing a mission the following conditions must have been met:

1. The mission must be planned in accordance with the guidelines set out in Planning a mission.
2. The Pre-flight checks must have been performed and passed.
3. The vehicle should be pointing with its nose towards the wind.
4. All flights must be started with a fully charged battery.
5. The operator and any observers must keep a safe distance from the vehicle, a 10m minimum is recommended.

Execute the mission

When all checks are performed, and everything is set up and working properly, you can start the mission. The mission can be started by sliding the "Start mission" activator.

Returning the vehicle during a mission

When the vehicle needs to be returned while executing a mission, the recommended method is to direct the UAV toward a waypoint that will provide a clean entry into the pre-defined landing sequence. You can change the active waypoint that the vehicle is following by clicking the desired waypoint from the fly screen and confirming the change request.

Please note: when changing the active waypoint, the vehicle will immediately change its altitude to the altitude of the selected item. It will not gradually climb or descend but reach the new altitude as fast as possible. It is therefore recommended to select a waypoint that has an altitude at which the vehicle can safely return from its current position. If a waypoint with a safe altitude is not available, it is recommended to first reposition the UAV to a safe location by tapping a location on the map. While repositioning the UAV it will maintain its current altitude.

Using the simulator is recommended to practice returning the UAV during a mission using the method described in this section.

Monitoring the mission

Throughout the mission, both the telemetry data and the vehicle should be monitored. This task can be performed by a single operator, but it is recommended to perform this task with one operator and an observer. The observer should continue to watch the vehicle and its surroundings and alert the operator of any problems or nearby traffic.

Note: It is highly recommended to practice the following exercise in the simulator several times before operating the vehicle.

From the flight screen, and when the vehicle is armed, the following key functions are available:

LAND: Land immediately.

The vehicle will land at its current location. If the vehicle is in Fixed Wing mode the vehicle will transition back to quadcopter mode first.

This button is called "Take off" while on the ground.

RTL: Return To Launch.

The vehicle will return to its takeoff point via the "Landing Pattern" command which consists of the "Loiter" waypoint and the "Land" item.

The vehicle will reach the "Landing Pattern" command in a straight line from its current location at its current altitude. If the current altitude is lower than the Return Home altitude in the Safety settings it will climb to this altitude. If the vehicle is flying in Quadcopter mode it will return to the "Landing Pattern" command and land in this mode. If the vehicle is in Fixed Wing mode it will return as Fixed Wing to the "Landing Pattern" command, perform a back transition when reaching the takeoff location, and land in quadcopter mode.

The advantage of facilitating the "Landing Pattern" command is that it will provide a clean entry into the pre-defined landing sequence and execute the transition and landing into the wind.

Note: using RTL is a last resort. The recommended method of returning the vehicle in fixed-wing mode is described in the section "Returning the vehicle during a mission" above.

PAUSE: The vehicle will hold its current position.

In Fixed Wing mode it will circle the current position with a radius of 100 meters. While in pause mode, when there are no open dialogs, tapping anywhere on the map will give you the ability to select "Goto location".

When sliding to confirm the goto command, the vehicle will proceed to the selected location.

ACTION: The "Action" button.

With the "Action" button the mission can proceed, or the flight altitude can be changed. The "Action" button becomes available when the vehicle is in HOLD mode (pause). See the picture below.

When tapping the action button two options become available.

CONTINUE MISSION will resume the mission towards the next waypoint indicated by a green color. If the option CONTINUE MISSION is not available you can resume the mission by switching to MISSION mode using the "Flight Mode" button.

The minimum and maximum altitudes can be set in the "Application Settings" under the "Q" icon.

Emergency Actions: This button will indicate the current state of the DeltaQuad.

When the vehicle is in flight (armed) this button can be clicked and the option to "Disarm" the vehicle will appear.

When clicking the "Disarm" button the emergency stop box will appear.

When confirming the emergency stop all motors will stop **IMMEDIATELY**. This procedure should only be used while the vehicle is on the ground or as a last resort to avoid damage to people or property.

Note: Using this function during flight will crash your vehicle and void your warranty.

Land: The vehicle will land at its current location. If the vehicle is in Fixed Wing mode the vehicle will transition back to quadcopter mode first.

FLIGHT MODE: This button displays the current flight mode. By tapping this button a new flight mode can be selected. Supported flight modes are HOLD, RETURN, and MISSION. Switching flight modes using this method will not require slider confirmation. **Note: When a new flight mode is selected this will be activated immediately.**

VTOL MODE: This button indicates if the vehicle is currently in multi-rotor or fixed-wing mode. Tapping this button will provide the option to switch modes.

At altitudes higher than 100m above ground, or in strong winds, it is not recommended to switch from fixed-wing to multi-rotor mode.

WAYPOINT items:

The waypoint items on the screen can be tapped. When tapped a dialog appears asking if the vehicle should proceed to the selected waypoint. When confirmed the vehicle will proceed in a straight line towards the selected waypoint. It will also immediately change to the altitude of the selected waypoint.

The operator should monitor the following:

During takeoff

The following should be monitored directly after takeoff while the vehicle is ascending vertically to its transition altitude.

Toilet bowling

Operator action: **LAND**

The vehicle should take off in a straight line after the first few meters. If the vehicle starts "toilet bowling" (circling up) the mission should be aborted and a sensor calibration must be performed.

Not holding position

Operator action: **LAND**

The vehicle should take off in a straight line. If the vehicle starts drifting from its position more than a few meters it should be commanded to LAND. Contact support to have your log files analyzed.

Takeoff failure

Operator action: **DISARM**

If the vehicle fails to take off or only one-half of the vehicle rises it is likely that the quadcopter propellers are damaged, mounted incorrectly, or upside down. The operator should disarm the vehicle and review the propeller's configuration as described in the assembly section.

Excessive current draw

Operator action: **LAND**

If the current draw indicated by CURRENT from the telemetry display exceeds 180 Amperes the flight should be aborted. The vehicle could be overweight, flying outside of tolerable wind conditions, or has a malfunction. In the case of a malfunction inspect the vehicle for visible damage to the propellers or a higher resistance in any of the motors. If there was no evident damage then contact Vertical Technologies support for analysis.

During transition

After reaching transition altitude the vehicle will commence the transition to fixed-wing flight. (switching from quadcopter to fixed wing). It will transition into the direction that the vehicle was placed in, but wind can have an effect on the direction, especially if the vehicle is not positioned with its nose directly into the wind. The vehicle will engage full thrust for 15 seconds using its pusher motor. After this period it should navigate towards the takeoff location or the first waypoint.

No forward motion

Operator action: **LAND**

If the vehicle is not moving forward or is drifting with the wind and does not seem to transition towards fixed-wing there is likely a problem with the pusher motor or propeller.

Flying backward

Operator action: **LAND**

If the vehicle starts flying backward with increasing speed it is likely to have the pusher propeller mounted in the wrong direction. The transition should be aborted and the pusher motor should be inspected.

High current slow forward flight

Operator action: **RTL**

If the vehicle is moving horizontally in the direction of the first waypoint at low speed, with the quadcopter motors still engaged after 15 seconds, and the current draw remains above 30 Amperes, it is likely that the mission did not issue a VTOL TAKEOFF command but a TAKEOFF command. The vehicle will attempt to complete the mission in quadcopter mode. If this was not intended, RTL should be initiated by the operator.

Note: The DeltaQuad can activate its pusher motor in quadcopter mode too. The spinning of the pusher motor is no indication that the vehicle is attempting fixed-wing flight.

During Fixed Wing flight

Switch to multi-rotor mode

Operator action: **Transition to fixed-wing or LAND**

There are some conditions where the vehicle can switch to multi-rotor mode. These include loss of positional awareness or accidental mode switching by the operator. In these events, it is usually prudent to attempt to resume fixed-wing flight by pressing the VTOL mode switch (G). If this fails for any reason, the vehicle must be landed. When the vehicle is higher than 200m this must happen immediately as the multirotor mode may consume too much energy to complete a full return.

Abort error displayed due to loss of altitude or maximum bank angle

Operator action: **LAND**

This error is displayed on the Ground Control Station when the vehicle has activated the failsafe system. The UAV must be landed as soon as possible. Do not attempt to complete the automatic return sequence if the vehicle is higher than 100m or further than 800m from the home position. If the battery is lower than 35% it should always be landed. Use the map to locate a safe area to land the UAV and direct the UAV to this location. Then press the LAND button to land immediately.

After such an event the cause must be determined before a new flight is attempted. Please contact Vertical Technologies support for assistance in analyzing the cause of the failsafe event.

Excessive altitude loss

Operator action: **Return or LAND**

During and shortly after transition, the vehicle may lose some altitude, this is generally not more than 5 meters. In extreme cases (high payload, strong wind). This can be up to 8 meters. The vehicle should recover from this loss quickly, and regain and maintain altitude. Some altitude gain or loss may occur when banking (changing direction). This should not exceed 5 meters.

If the vehicle does not maintain altitude, or if the altitude error exceeds 10m and the vehicle does not recover from this altitude error an RTL should be commanded. If the vehicle does not adequately perform the RTL procedure (continues to lose altitude or fails to navigate back) a LAND instruction should be given. After a LAND instruction is given, and the vehicle is performing a landing in quadcopter mode, the RTL instruction can be given again to have the vehicle return in quadcopter mode. This should only be attempted when the vehicle is less than 1km from the takeoff site and more than 50% of the battery capacity is available.

The reason this can occur could be related to weight, balance, or a problem with the servos or pusher drive. A thorough inspection of the vehicle is required. If the problem can not be found and resolved you should contact Vertical Technologies support.

Failure to track the mission path

Operator action: **Return or LAND**

During the transition, the vehicle does not fly in the direction expected:

When the transition phase completes, the vehicle should fly towards its takeoff location or first waypoint. If the vehicle does not follow its intended path after the transition phase, an RTL should be commanded. If the vehicle does not adequately perform the RTL procedure (continues to lose altitude or fails to navigate back) a LAND instruction should be given. After a LAND instruction was given, and the vehicle is commencing a landing in quadcopter mode, the RTL instruction can be given again to have the vehicle return in quadcopter mode. This should only be attempted when the vehicle is less than 1km from the takeoff site and more than 70% of the battery capacity is available.

The reason this can occur can be related to a failure of the servo actuation or if a mission is incorrectly loaded.

Excessive pitch

Operator action: **Increase cruise throttle / Return**

The DeltaQuad should cruise at an average pitch angle between 3 and 9 degrees unless a change in altitude is commanded. If the pitch angle consistently exceeds 12 degrees while the vehicle is not attempting to climb to a higher altitude the cruise throttle should be increased. Increasing the cruise throttle can be done by changing the parameters as described in the Key parameters section. This parameter can be changed during flight. If this does not resolve the problem the flight should be aborted by issuing an RTL command.

Note: When changing the cruise throttle during flight special care must be taken to monitor the battery level.

The reason for this could be related to sensor calibration, overweight, too low cruise throttle, or a problem with the fixed-wing drive. To resolve this attempt to level the vehicle as described in the sensor calibration section, verify the weight or increase the cruise throttle. If the problem persists please contact Vertical Technologies support.

Battery level and current consumption

Operator action: **Return**

The battery level percentage indicated in the top bar of the flight screen should be monitored throughout the flight. The percentage should always be higher than the relative distance the vehicle still has to travel. For example, if only 50% battery remains, more than 50% of the mission should have been completed. The CURRENT and CONSUMED values will also help determine this. The DeltaQuad should draw between 9 and 15 Amperes of current on average during cruise flight. This value increases;

- The vehicle is flying significantly above sea level
- If the vehicle is flying with maximum payload.
- As the battery percentage drops.
- When the vehicle is climbing or banking.
- When the cruise throttle is set higher.
- When the LiPo gets older.
- When a power-consuming payload is active.

Ground speed

Operator action: **Increase cruise throttle**

The DeltaQuad will generally maintain a constant speed through the air, but wind conditions will impact the effective ground speed. If the ground speed drops below 6 m/s the cruise throttle should be increased. Increasing the cruise throttle can be done by changing the parameters as described in the Key parameters section. This parameter can be changed during flight.

Note: When changing the cruise throttle during flight special care must be taken to monitor the battery level.

When this happens the vehicle is likely flying in wind conditions that exceed the specified tolerance.

During back transition

When the DeltaQuad is flying towards its last waypoint (the VTOL_LAND waypoint) it will determine the appropriate distance from the waypoint to initiate its back transition. The distance depends on the current ground speed and can vary between 5 and 100 meters from the land position. During the back transition, the DeltaQuad will activate its pusher motor in reverse direction to slow down.

Excessive overshoot

Operator action: **None**

If the vehicle overshoots its landing waypoint significantly and does not seem to slow down during back transition, there could be a problem with the pusher reverse system. The vehicle should be thoroughly inspected for loose connectors on the flight controller (specifically connectors 7 and 8 as indicated on the wiring diagram). If no problem was found with the connectors the vehicle should be grounded and undergo extended maintenance.

Unstable descent

Operator action: **None**

If the vehicle becomes unstable during landing the land speed as indicated in the safety features is likely set too high.

No auto disarm after touch down

Operator action: **Disarm**

The DeltaQuad should disarm automatically 5 to 10 seconds after touch down. If the vehicle does not disarm automatically the disarm command (emergency stop) should be sent. This command can be sent by pressing the "Armed" label.

The reason for this could be related to landing on a significantly uneven surface or slope. It can also indicate the sensors need calibration.

Post-flight

When the DeltaQuad EVO has completed operations it should be switched off, inspected, dismantled, and stored. Flight logs should be retrieved and registered.

Switching off the vehicle

Before approaching the vehicle to switch it off note the following;

- The vehicle should never be approached when the motors are spinning.
- In the unlikely event of a crash, the vehicle should not be approached within 15 minutes. The battery could have been damaged and may ignite.
- Always stay clear of the propellers until the vehicle has been powered off by disconnecting the main flight battery.

To switch the vehicle off open the canopy and remove the lid. Then disconnect the main battery connector and remove the battery. The battery should be stored directly and safely.

Inspect the vehicle

After a landing, specifically a hard landing or a grass landing, the DeltaQuad EVO should be inspected for damage. Inspecting the vehicle visually at the landing site can help in determining the cause of any problems that might arise in the future. It is recommended, specifically when in doubt or with visible damage, to take pictures of the vehicle before dismantling it.

If there is any dirt on the vehicle or the propellers this should be removed with a damp cloth. Dirt on the wings, fuse, or propellers will significantly impact the performance.

Special care must be taken to inspect the propellers both before and after every flight. If there is any visible or palpable damage to a propeller it should be replaced directly in accordance with the preventative maintenance section.

Dismantle the vehicle

Dismantle the vehicle in accordance with the assembly section. If you are able to transport and store the vehicle safely with only the wings detached this is recommended as it will reduce the risk of assembly problems.

Transporting and storing the vehicle

The DeltaQuad EVO should be transported and stored inside the DeltaQuad EVO Flightcase.

Retrieving the onboard logs and registering the flight

When a sim card is installed inside the UAV, the logs will be uploaded automatically to your Auterion Suite account. Logs can also be manually retrieved through the Analysis section of the Ground Control Station.

Maintenance

This chapter covers the maintenance of your vehicle and the logging of your flights.

Chapter index

- [Sensor calibration](#)
- [Firmware upgrade](#)
- [Flight logs](#)
- [Preventive maintenance](#)

Sensor calibration

The DeltaQuad EVO requires a compass calibration in the following conditions:

- When indicated by events described in this manual.
- When the telemetry readings are inconsistent with reality.

The DeltaQuad EVO requires a gyro calibration in the following conditions:

- When indicated by the UAV

The DeltaQuad EVO requires an accelerometer calibration in the following conditions:

- When indicated by the UAV

The DeltaQuad EVO requires a level horizon in the following conditions:

- When indicated by the supplier

Accessing the calibration screen

Sensor calibration is performed in Auterion Mission Control. To access the sensor calibration, you will need to switch the vehicle on and establish a connection between the Ground Control Station and the vehicle. Navigate to the settings view and select the Sensors tab.

QGroundControl will issue a warning about sensor calibration over a WiFi connection. This can safely be ignored by clicking OK.

The following sensor calibrations should be performed:

- Compass
- Gyroscope
- Accelerometer
- Level Horizon

All calibrations should be performed with the VTOL modules attached, and any additional payload installed and powered on.

After every calibration step, the autopilot must reboot. The autopilot can be rebooted quickly from the parameters tab under the tools button.

Compass calibration

A compass calibration is best performed outside, away from metallic objects, electrical or magnetic interference. To start the compass calibration, click the compass button and follow the instructions on the screen. The calibration process starts when clicking OK. The autopilot orientation parameter in the GCS should remain unchanged. A compass calibration involves rotating the vehicle 3 times over all axis. This calibration step can be performed by hand. The canopy should be closed and the LiPo battery and any additional payload should be inserted and securely fastened.

Perform the calibration as indicated by the images on the ground station. When all axis are finished (images turn green) click OK, leaving the external magnetometer orientation unchanged. Then reboot the vehicle.

After the compass calibration ALWAYS verify the compass is reading correctly by pointing the vehicle north, east, south and west and at every turn verify that the vehicle icon on the ground station is pointing in the correct direction, and remains pointed in that direction for at least 30 seconds. If the compass is not reading correctly by more than 8 degrees, please retry the calibration. If the problem persists please contact Vertical Technologies.

Gyroscope calibration

The gyroscope calibration is best performed indoors. It requires the vehicle to sit level based on the VTOL arms. To level the vehicle based on the VTOL arms it is recommended to find a level surface (a table) and place 4 objects of equal height under the quadcopter motors. For example soda cans. The foam underside of the vehicle should be free from the table and the carbon VTOL arms should sit level horizontally.

When the vehicle is sitting level, press OK to start the calibration. This will complete in about 20 seconds. The vehicle should not be touched or moved during the calibration process. Then reboot the vehicle. If, for any reason, the vehicle is moved during the calibration process then repeat the process from the beginning.

Accelerometer calibration

To start the accelerometer calibration, click the accelerometer button and follow the instructions on the screen. The calibration process starts when clicking OK. The autopilot orientation parameter in the GCS should remain unchanged. An accelerometer calibration involves positioning the vehicle on all axis. This calibration step can be performed by hand. The canopy should be closed and the LiPo battery should be inserted and securely fastened.

Perform the calibration as indicated by the images on the Ground Control Station, ensuring the vehicle is motionless at each point in the calibration process. Then reboot the vehicle.

Level horizon

 **WARNING:** This calibration is rarely needed outside of the factory. Performing this calibration incorrectly can cause the vehicle to become unstable or crash. Do NOT perform this calibration without consulting your DeltaQuad representative.

Before leveling the horizon all other calibrations, except compass calibration, must have been completed.

The Level Horizon calibration is best performed indoors. It requires the vehicle to sit level on a calibrated flat surface with the landing gear retracted.

When the vehicle is sitting level, press OK to start the calibration.

Firmware upgrade

The DeltaQuad EVO uses its Ground Control Station to perform automatic upgrades. When purchasing a DeltaQuad EVO you will be notified of relevant firmware upgrades for your vehicle via email. To initiate the firmware upgrade you will need to provide your Ground Control Station with an internet connection.

For critical upgrades, the email notification will contain a method to verify if it has been completed successfully.

Flight logs

The DeltaQuad EVO records onboard logs that contain vast amounts of information regarding the flights. These onboard logs will be uploaded to Auterion Suite through Cloud connectivity.

Maintaining a logbook

Asset management

Keep track of payloads, parts, and other peripherals, see asset usage per flight, lifecycle state, and proactive measures.

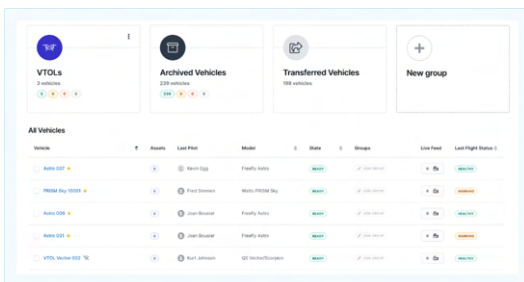

Fleet management

Monitor vehicle overview and status, manage software and app deployment, and log notes to facilitate transparency and collaboration.

As an alternative DeltaQuad recommends the use of AlarisPro. The DeltaQuad EVO is a known vehicle in this system and all components and maintenance schedules are pre-configured.

For other, or self-designed log books the following information should at least be present;

Per vehicle

- Serial number
- Total flight hours
- Last maintenance cycle
- Replaced components including the replacement date

Per flight

- Vehicle serial number
- Date and time
- Flight time
- Link to the on-board log and/or flight review
- Operator
- Weather conditions/wind speed
- Flight notes, failures, damage, and field replacements

Preventative maintenance

To keep your DeltaQuad EVO in proper condition the following steps should be taken:

After every flight

- Clean the propellers of any dirt and inspect for damage.
- Clean the fuselage and wings, this will improve performance.
- Inspect the avionics, and make sure all components are still securely attached in their proper place and all connectors are securely fastened.

After 200 flights or 12 months

To keep your vehicle in the best condition and safe to operate beyond this point scheduled maintenance should be performed. A maintenance kit can be ordered from your DeltaQuad representative.

Replacing components

The DeltaQuad EVO has been designed to allow easy replacement of components. Every component on the DeltaQuad EVO is available as a replacement part.

The maintenance kit includes detailed instructions on all replacement parts.

DeltaQuad EVO payloads

This section will describe in detail the functionality of every available payload for the DeltaQuad EVO.

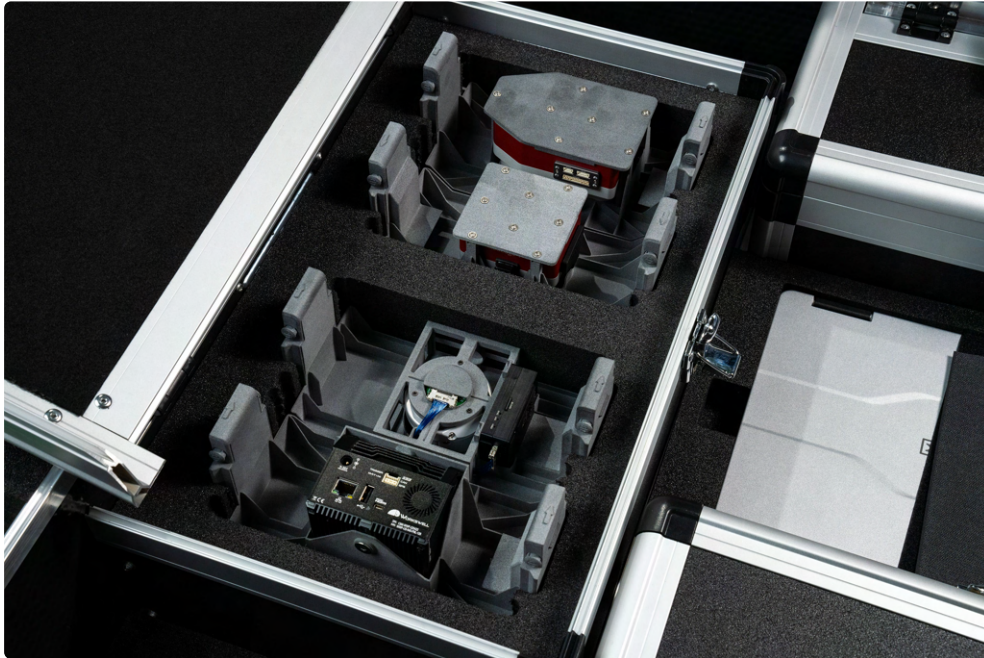

- [NextVision](#)
 - [Raptor](#)
 - [Nighthawk2-V/UZ](#)

NextVision

Field-proven stabilized cameras for commercial, industrial, and security applications.



This section will discuss how to install, set up, and use all NextVision payloads.

- [Raptor](#)
- [Nighthawk2-V/UZ](#)

Raptor

RGB AND THERMAL - Single payload

The Raptor is a lightweight long-range dual EO-IR stabilized camera turret. It features a significant IR range increase and a X80 EO zoom.

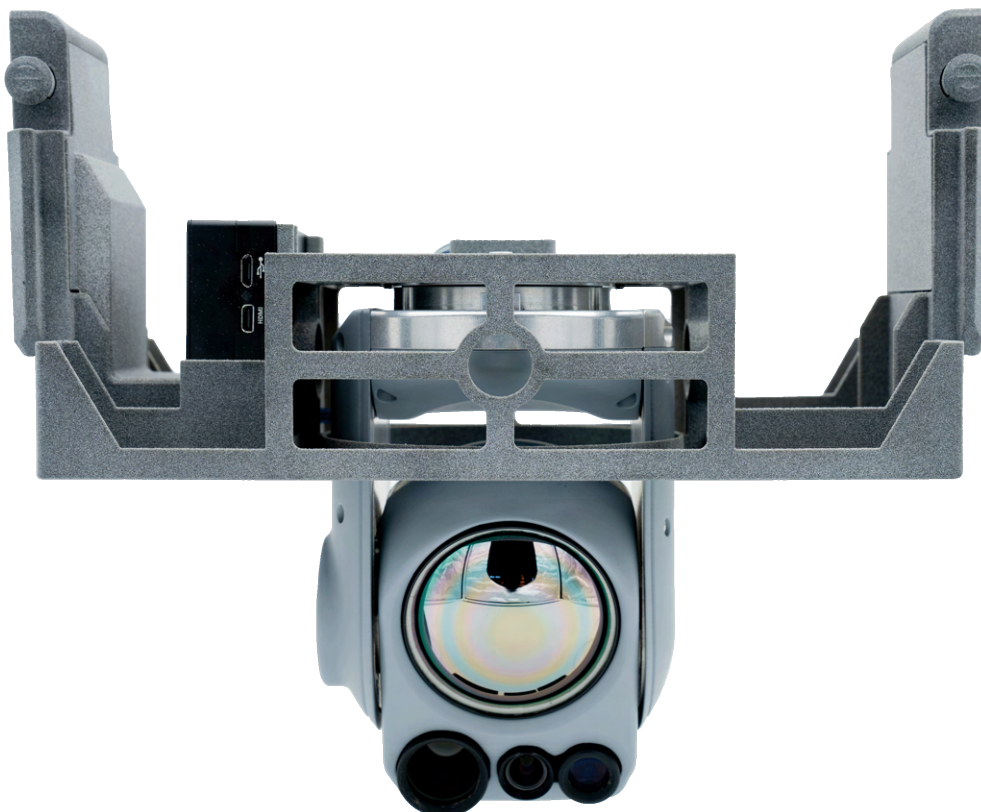

ZOOM	X80 (X40 + X2 digital)
FOV	60° WFOV – 1.5° NFOV – 0.75° DFOV
THERMAL RESOLUTION	1280×720
PITCH FOR	-45° to +80°
YAW/ROLL FOR	-180° to +180° Optional 360° Continuous
WEIGHT	850 grams
DIMENSIONS	D-90mm x H-120mm

Nighthawk2-V/UZ

RGB AND THERMAL - Single payload

NightHawk2

The NightHawk2 is an EO/IR stabilized camera with a mere weight of 250 grams. The NightHawk2 delivers powerful thermal observation alongside long-range visible imagery.

NightHawk2-V

The NightHawk2-V is a small-size dual EO-IR stabilized camera turret enabling long-range observation. Implementing technology breakthroughs makes the NightHawk2-V the best camera in its weight class.

NightHawk2-UZ

NightHawk2-UZ is a dual EO-IR stabilized camera turret crafted for long-range observation applications that demand very low weight. Embodying technology innovations, NightHawk2-UZ provides unmatched capabilities.

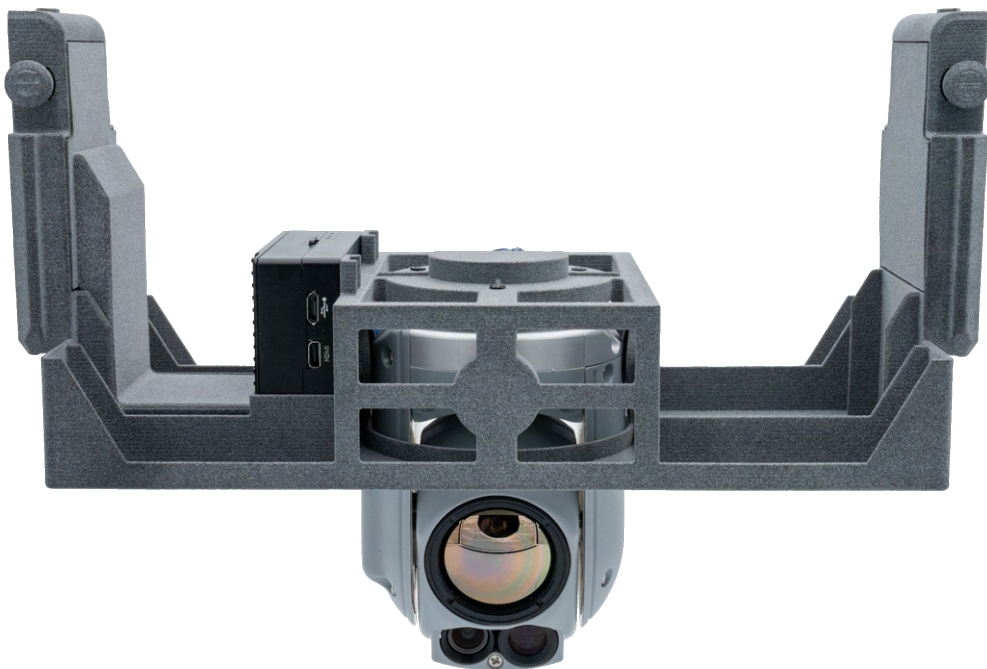

Text	Nighthawk2	Nighthawk2-V	Nighthawk2-V/UZ
ZOOM	X40 (X20+X2 digital)	X40 (X20 + X2 digital)	X40 (X20 + X2 digital)
FOV	60° WFOV – 3° WFOV – 1.5° DFOV	60° WFOV – 3° NFOV – 1.5° DFOV	60° WFOV – 3° NFOV 1.5° DFOV
THERMAL RESOLUTION	640×480	640×480	1280×720
EO-IR	Single	Dual	Dual
PITCH FOR	-45° to +135°	-45° to +135°	-45° to +135°
YAW/ROLL FOR	-180° to +180°	-180° to +180°	-180° to +180° Optiona 360° Continuous
WEIGHT	460 grams	530 grams	560 grams
DIMENSIONS	D-64mm x H-94 mm	D-64mm x H-94mm	D-64mm x H-94mm

Controlling the camera

The FLY view

When the DeltaQuad Evo and the Ground Control Station are powered and connected the video feed will be visible in AMC either in the main screen or in the small video screen in the bottom-left section of the FLY view. You can switch the main screen between the satellite map and video feed by tapping on the small screen in the bottom-left corner.

On the right side of the fly screen, the camera controls are displayed. These controls allow you to change the mode of the camera system.

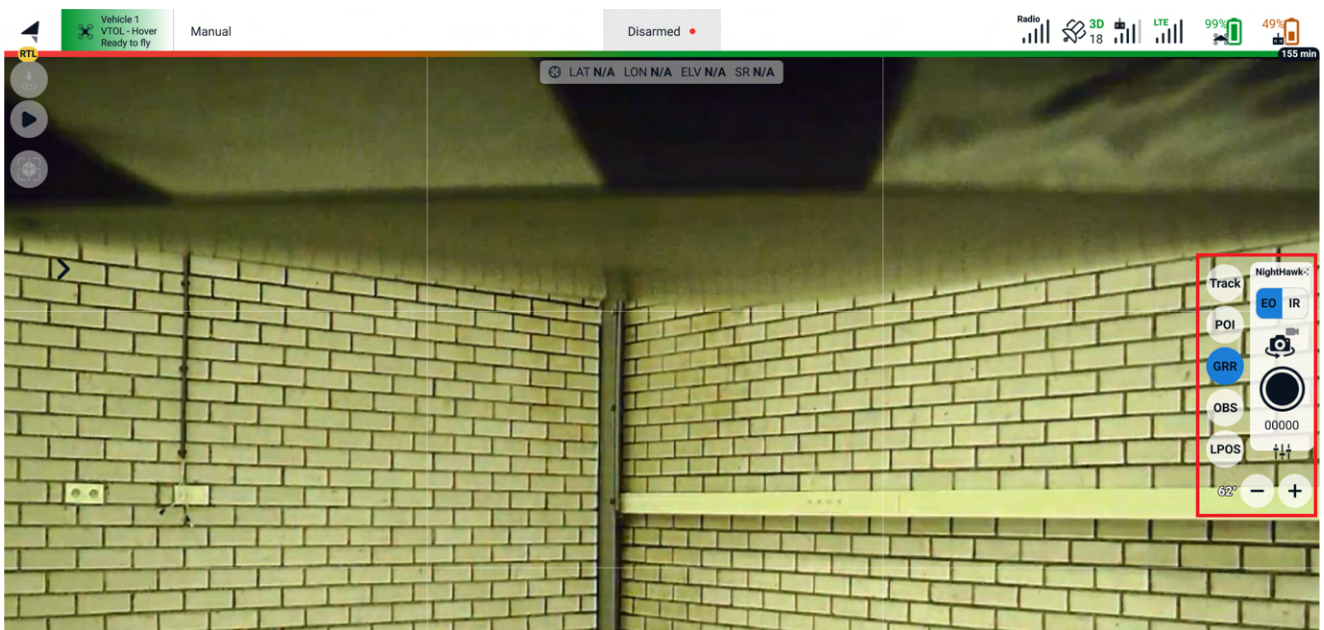

The camera controls window allows you to set the following camera modes:

Track	By pressing the "Track" button and subsequently choosing an object within the video display, you can instruct the gimbal to track that specific object. This functionality is most effective when there is a clear contrast between the object and its background.
-------	--

i **Target tracking** is the mode where the camera will remain focused on a target. The target can be moving or static. Activate target tracking by tapping on the Track button. Simply tap anywhere in the video feed and the camera will enter tracking mode and track the target that was tapped on. You can tap several times to fine-tune your target tracking mode.

When a target is being tracked, a white square is displayed on the object that is being tracked. By moving the camera joystick, tracking is disabled and the camera returns to the previous mode.

POI	You can establish a Point of Interest (POI) on the map view by simply tapping the POI button and then tapping on your desired location on the map. Alternatively, you can set a POI within camera view by selecting the POI option and tapping on the specific point of interest within the video frame. The gimbal will then make an effort to maintain focus on the selected POI's location on the ground.
GRR	In this mode, the camera will hold its position relative to the ground. This is the recommended mode for camera control. The joystick controls the camera.
OBS	In this mode, the camera will hold its position relative to the vehicle's movement. The joystick controls the camera.
LPOS	LPOS (Local Position) is the mode in which the camera tracks the orientation of the aircraft, so when it makes a turn, the camera maintains the same angle relative to the aircraft.
EO	(Electro-optical) Activates the RGB (normal color video) mode of the camera.
IR	(Infra-red) Activates the Infrared camera for night vision and seeing between foliage.



When clicking on the camera symbol the recording mode can be switched between photo and video recording.

The red button indicates the video recording mode.

The black button indicates the photo recording mode.



The -/+ button controls the zoom of the camera. The zoom level is indicated by degrees.



The fader button opens the camera menu with access to camera settings and general settings.

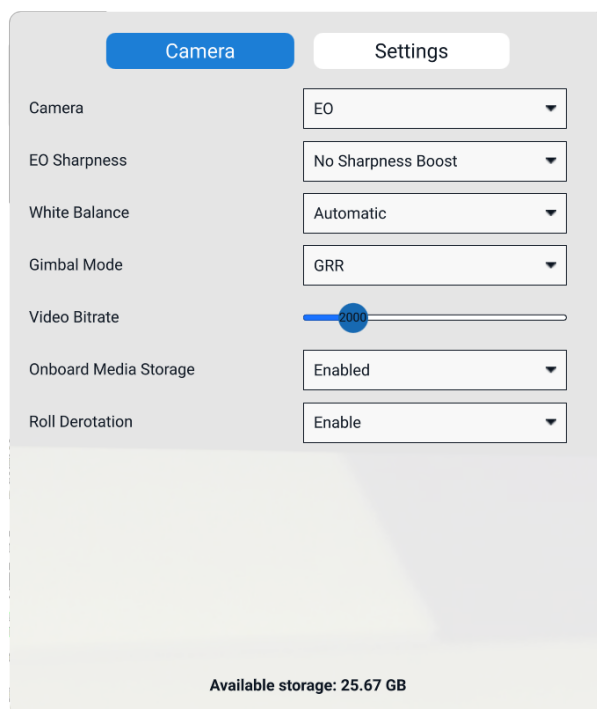

The camera settings tab gives access to the following options:

Camera: Switch between EO and IR mode. This mode can be also accessed via the camera controls in the Fly view.

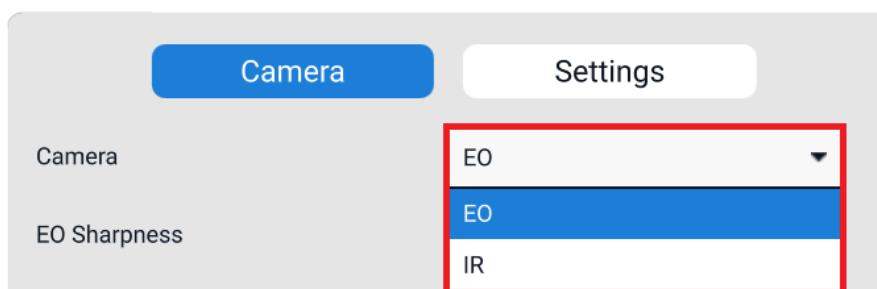

EO Sharpness: This option gives three different degrees to boost the sharpness of the image.

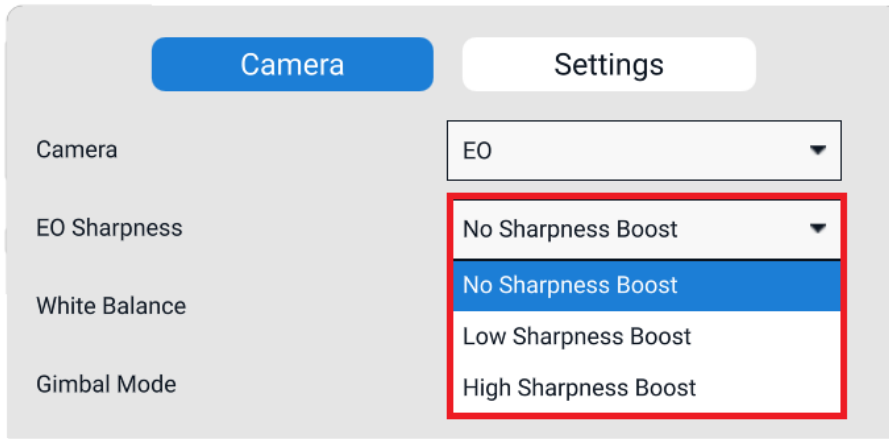

White Balance: Switch between Automatic and Manual mode.

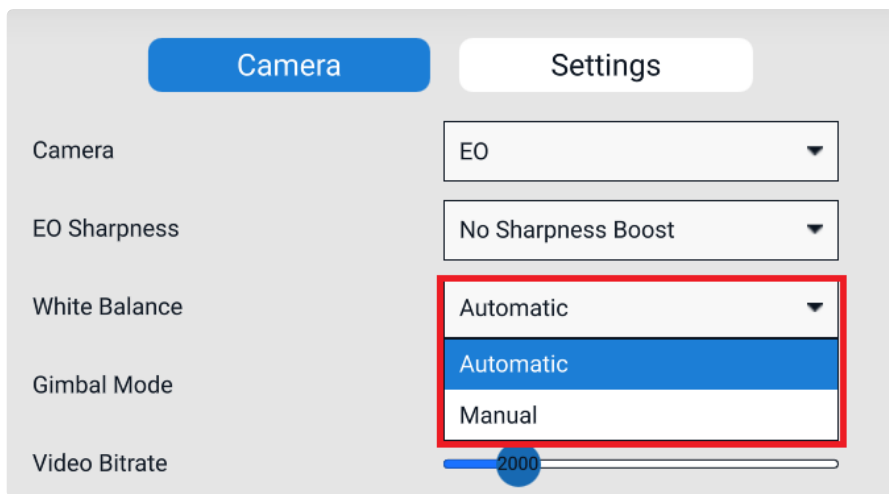

When White Balance is set to Manual a slider appears to set the white balance manually:

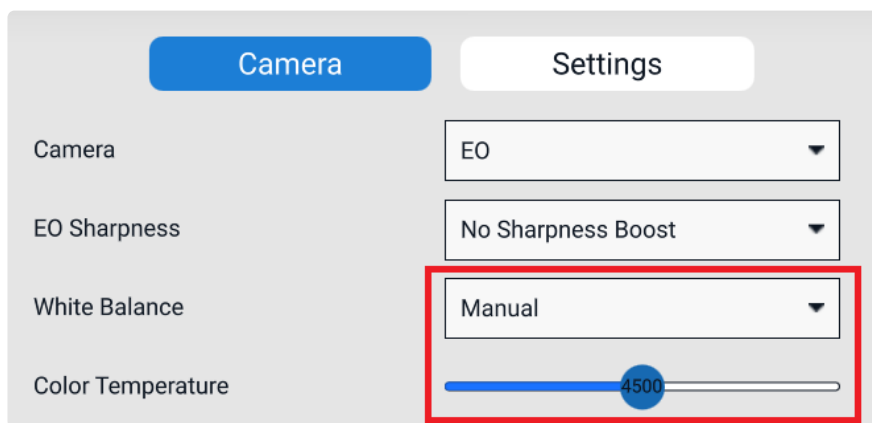

When IR is chosen as the camera mode more options will be available for this mode:

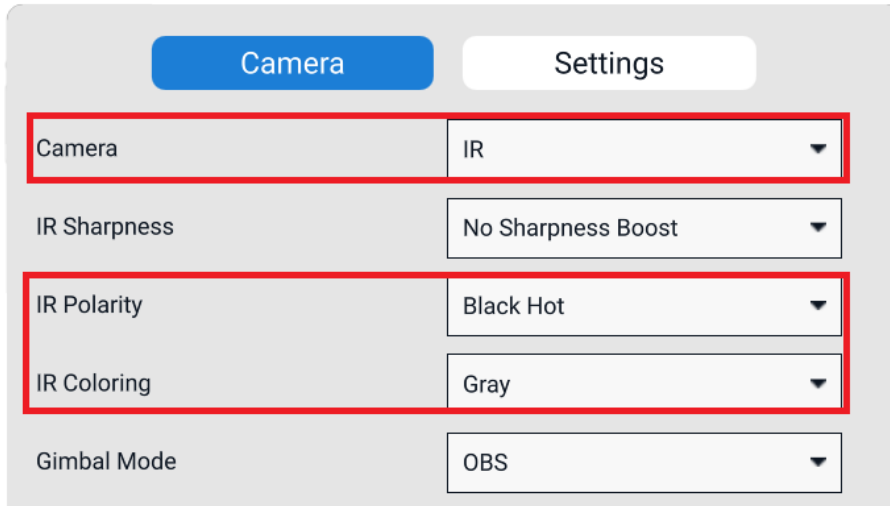

IR Polarity: In this tab, the operator can choose to have either Black Hot or White Hot.

IR Coloring: In this tab, the operator can choose between the Gray scale or the Color scale.

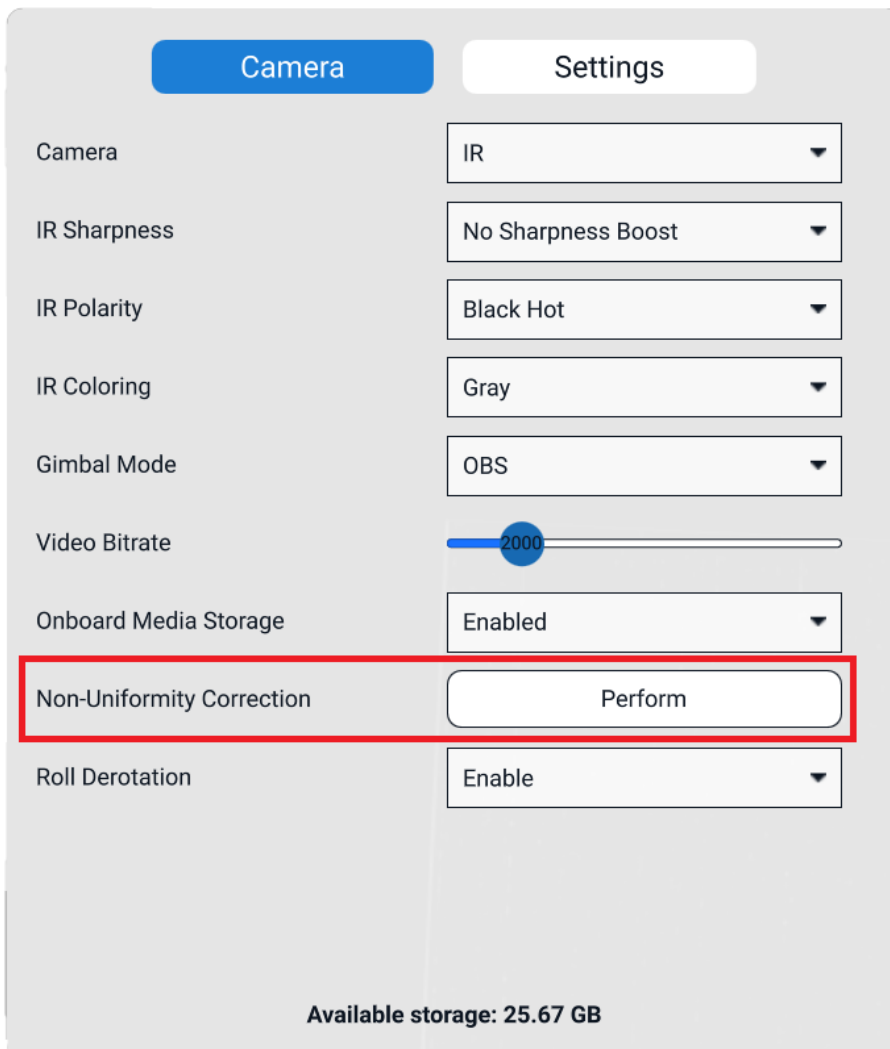

Non-Uniformity Correction: (NUC) After engaging the IR mode, the IR camera needs to be calibrated for a clear view. This is done automatically by the system. NUC performs this calibration which takes about 3 seconds.

Gimbal Mode: In this tab, the operator can switch between GRR, OBS, and LPOS gimbal modes. These camera control options are also available in the Fly view via the camera controls.

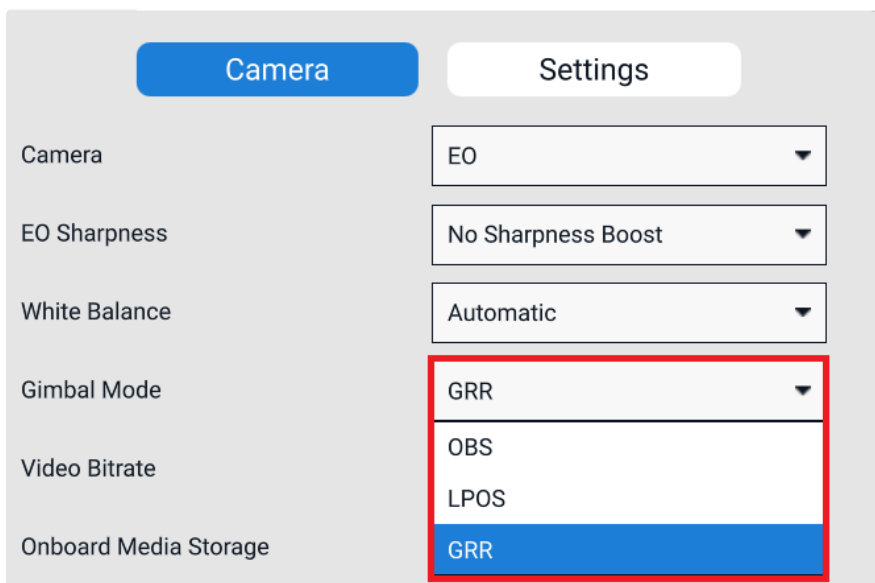

Video Bitrate: With this slider the video bitrate can be set. By default, the value is set to 2000. The higher the bitrate the better the video image will be but at the cost of the maximum telemetry distance.

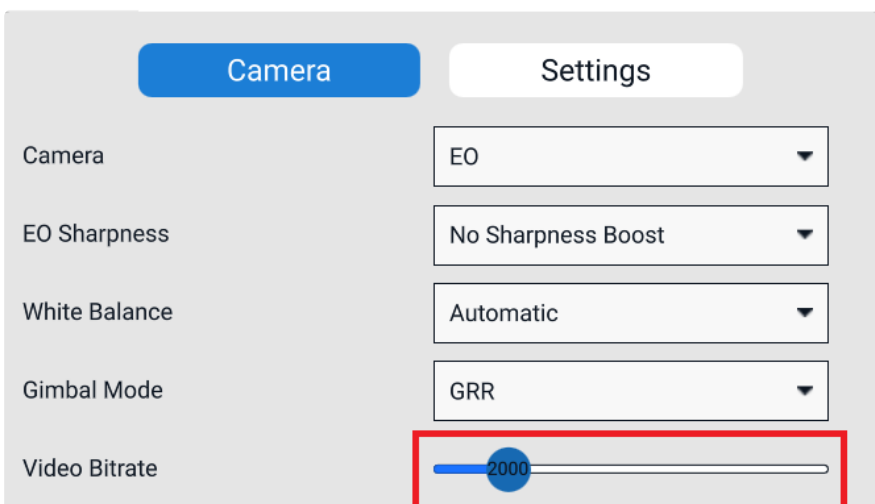

Onboard Media Storage: With this option, you can enable or disable the Onboard Media Storage.

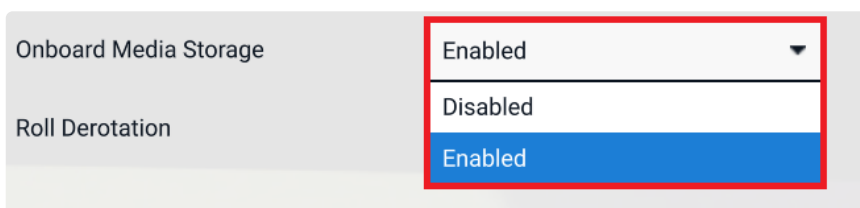

At the bottom of the window, the available storage for video recording will be displayed.

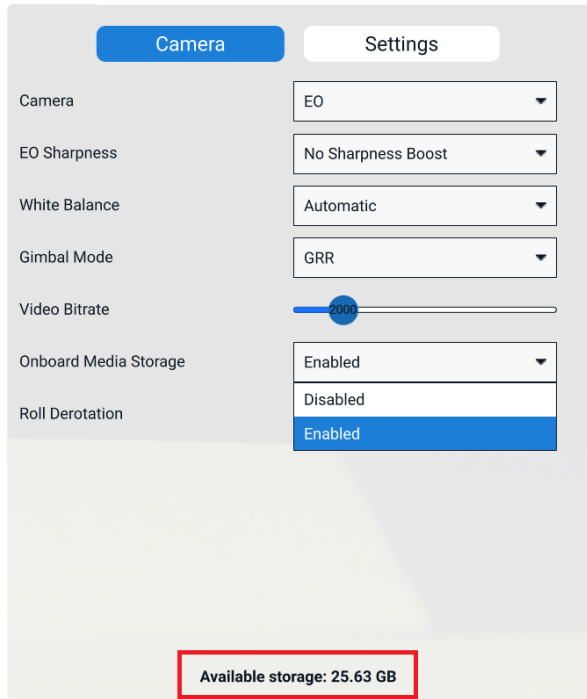

Roll Derotation: The camera is capable of keeping the video stream aligned with the horizon when the vehicle is banking. This is called Roll Derotation.

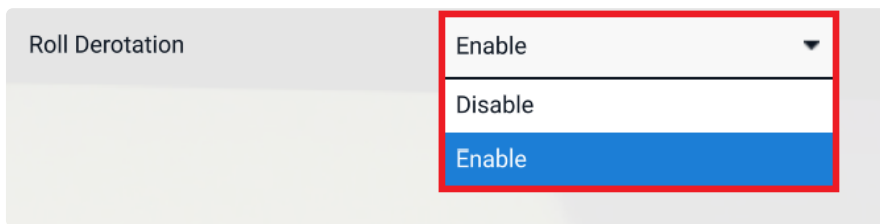

When roll derotation is active the video image displayed on the controller will rotate in such a way that the image remains level. The trade-off is that the video can show black corners when the vehicle is banking.



Roll Derotation enabled



Roll Derotation disabled

The settings tab on the upper right corner of the menu gives access to general settings:

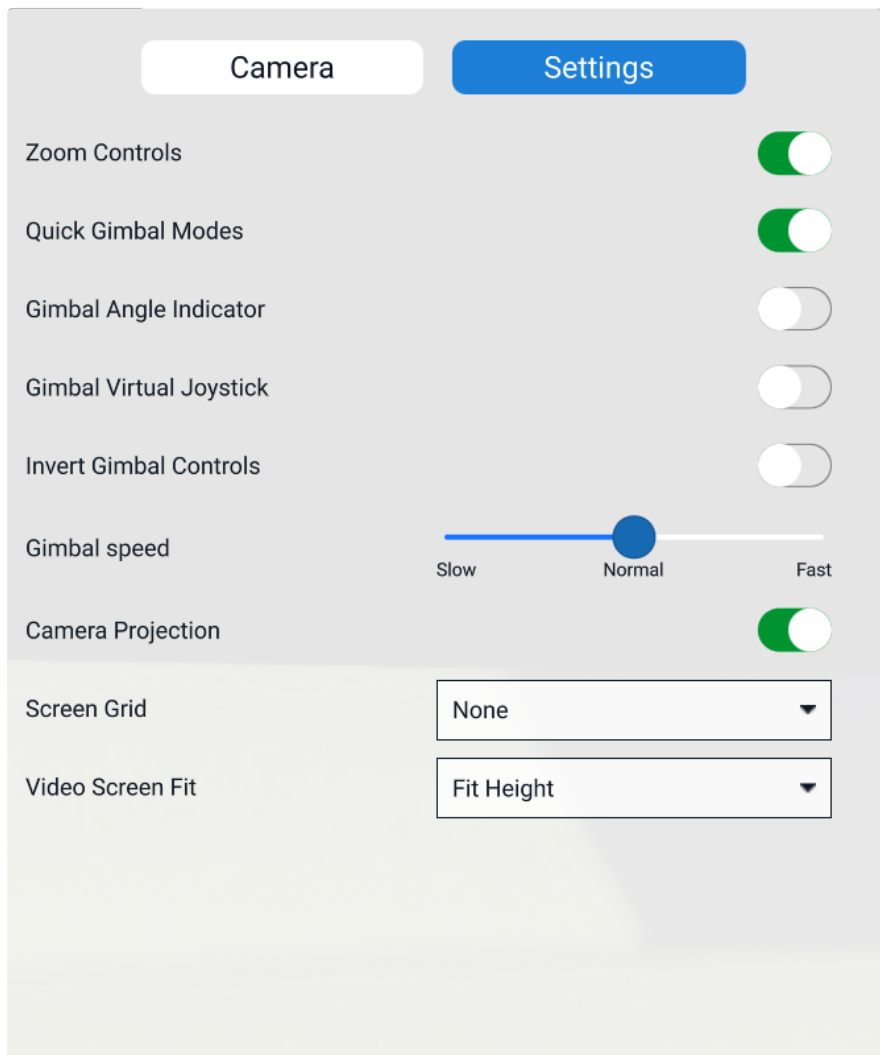

Zoom Controls	Enables zoom controls in the camera control window.
Quick Gimbal Modes	Makes the gimbal modes (GRR, OBS, and LPO) available in the camera control window.
Gimbal Angle Indicator	The camera angle (in degrees) will be displayed in the Fly view.
Gimbal Virtual Joystick	Enables a virtual joystick left of the camera control interface in the Fly view.
Invert Gimbal Controls	Inverts the gimbal controls.
Gimbal speed	With the slider, the gimbal speed can be set. It is set to Normal by default.
Camera Projection	When the map is selected in the Fly view the camera's Field of View is indicated by a blue circle.
Screen Grid	This option will display a grid overlay on top of the video image.

The grid option is either a square or a screen division by 3x3:

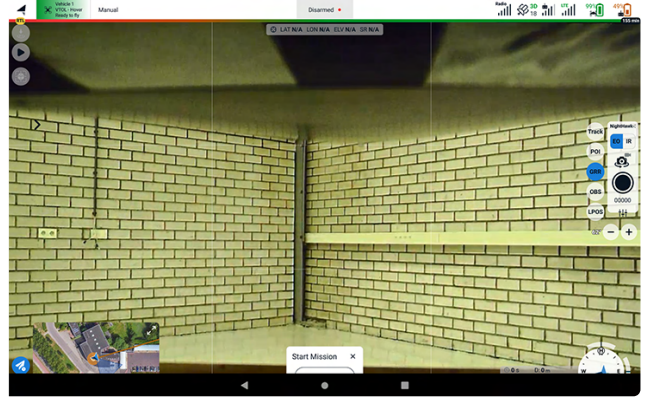
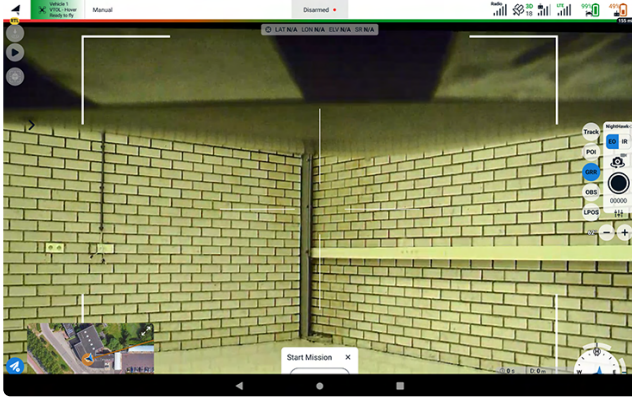

Target following

Target following is the mode where the vehicle actively follows a tracked target. To engage target following mode you will first need to track a target. Once a target is locked you can engage target following by giving the Target Following command. The command is located on the left side of the Fly view where the pilot commands are located.



The system will start following a target when these conditions are met:

- A target is actively being tracked
- The target is less than 2,000 meters away from the vehicle
- Target following has been enabled

i TIP: The camera can rotate 360 degrees. To avoid reaching the maximum rotation angle it is recommended to fly towards, follow, or directly above a tracked object.

When first entering target following mode the vehicle will switch its flight mode to "HOLD" mode. The target following system will then issue reposition commands every 1.5 seconds for as long as the target following conditions are met. If the conditions are no longer met the vehicle will remain circling the position of the last known target location. If the tracked target is lost you can re-engage target tracking by simply tapping on the object in the video feed, the system will follow any target selected target following is enabled and the conditions are met.

If the vehicle is flying above the tracked target, or if the vehicle is flying faster than the tracked target, it will circle above the target keeping the target in view at all times.

If target following is disengaged the vehicle will start circling its current position.

Connecting a second screen

This section describes how to connect a second screen to your DeltaQuad Controller.

Introduction

The second screen function can stream the video feed to a local device.

The DeltaQuad Controller provides an RTSP-based video stream. The second screen will connect to the DeltaQuad Controller, not directly to the UAV. This is to prevent the UAV from having to use double the amount of bandwidth.

The video feed displayed on the second screen is the direct video feed from the camera.

Using a WiFi hotspot

If your controller is connected to a 5GHz WiFi network or hotspot, a second device can connect to the same network. For information on how to connect the DeltaQuad Controller to a WiFi network or hotspot, please see the [DeltaQuad Controller section](#).

In order to stream the video feed locally to a second screen you need:

- The "IP address" of the DeltaQuad Controller.
- [VLC Media Player](#) (recommended software) for viewing the video stream on the second screen device. The VLC Media Player is cross-platform compatible and can be installed on many devices.



- The DeltaQuad Controller and the second screen device need to be connected to the same Wi-Fi network or hotspot.
- In order to ground-test the setup and check the video feed it is necessary to power the DeltaQuad Evo and establish a radio connection between the Evo and the DeltaQuad Controller.

⚠ When ground-testing the video feed with an infrared-capable camera it is important to provide active cooling. We recommend a USB fan pointed directly towards the camera.

Once the DeltaQuad Controller is connected to the Wi-Fi network or hotspot you can determine the "Wi-Fi IP address" that was assigned to the DeltaQuad Controller by opening the Evo Control Panel.

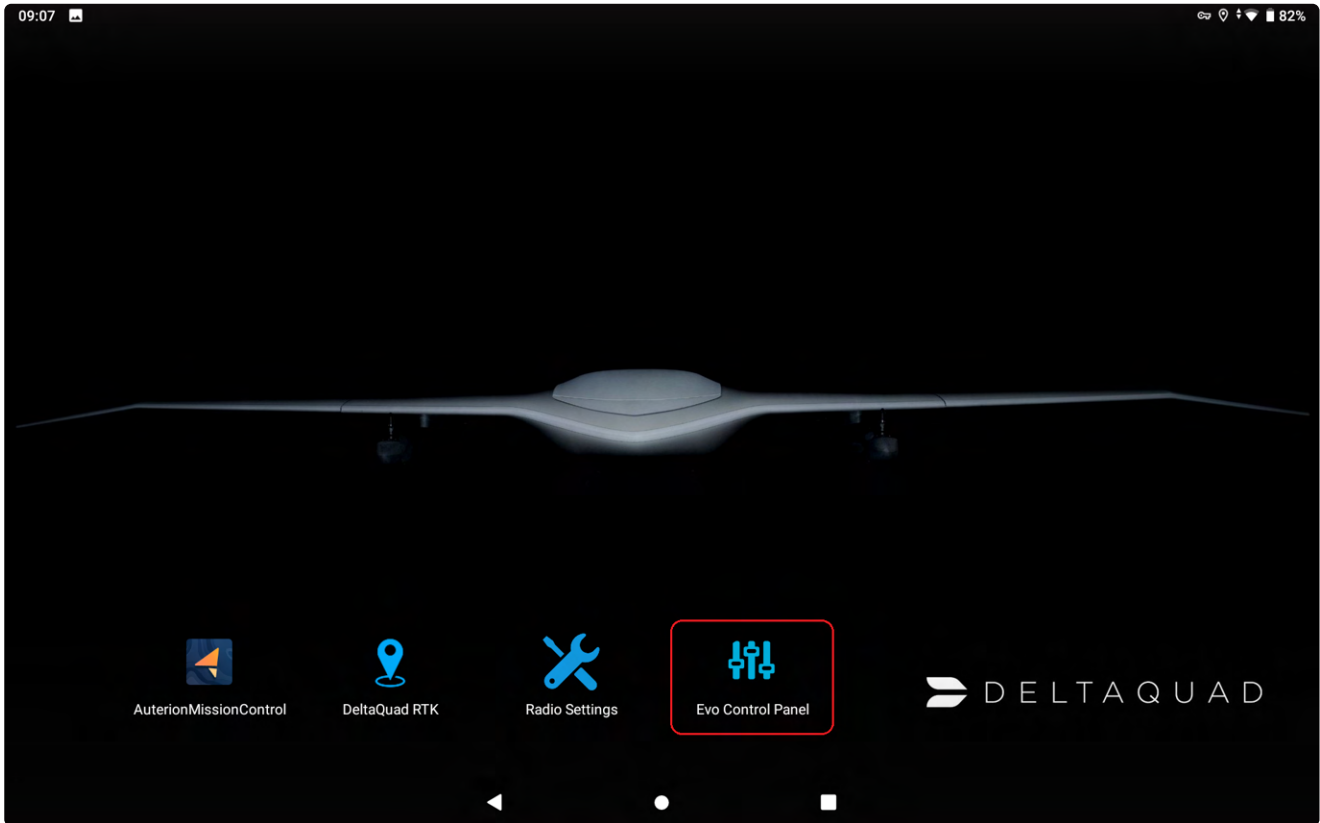

Here you will find the Wi-Fi IP address which shows the values for the IP address assigned by the Wi-Fi network or hotspot. The value required is the sequence of 4 numbers separated by a dot, in our example: 192.168.2.68

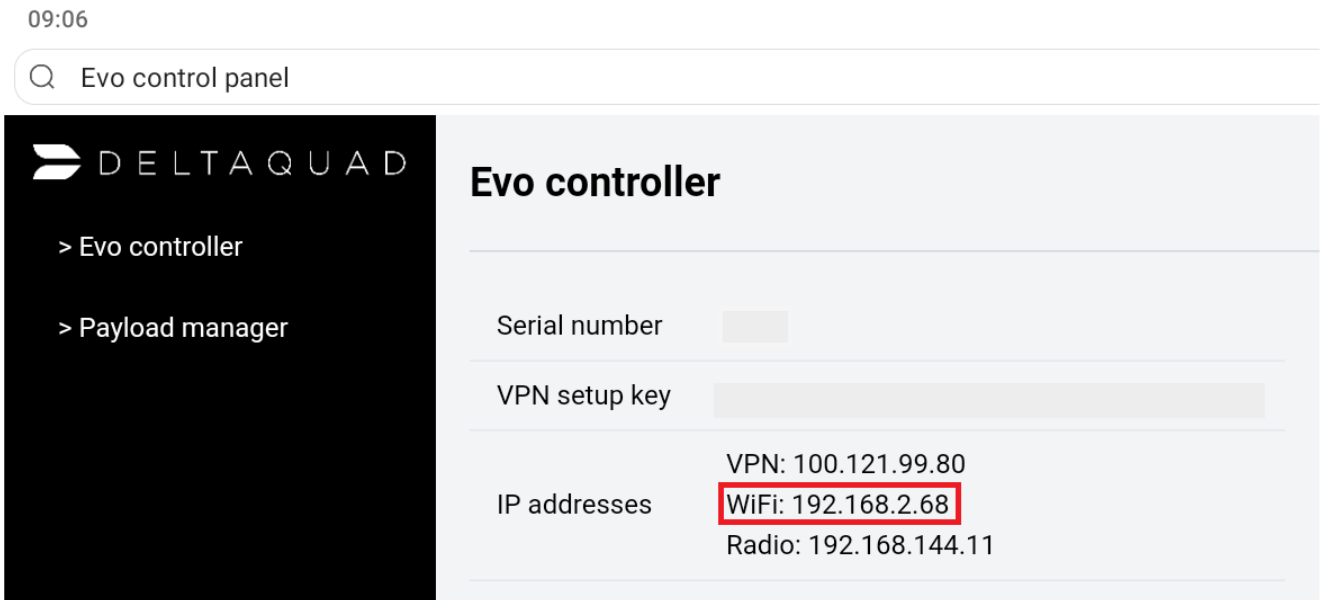

Make sure that the second screen device is connected to the same Wi-Fi network or hotspot as the DeltaQuad Controller and open the [VLC Media Player](#).

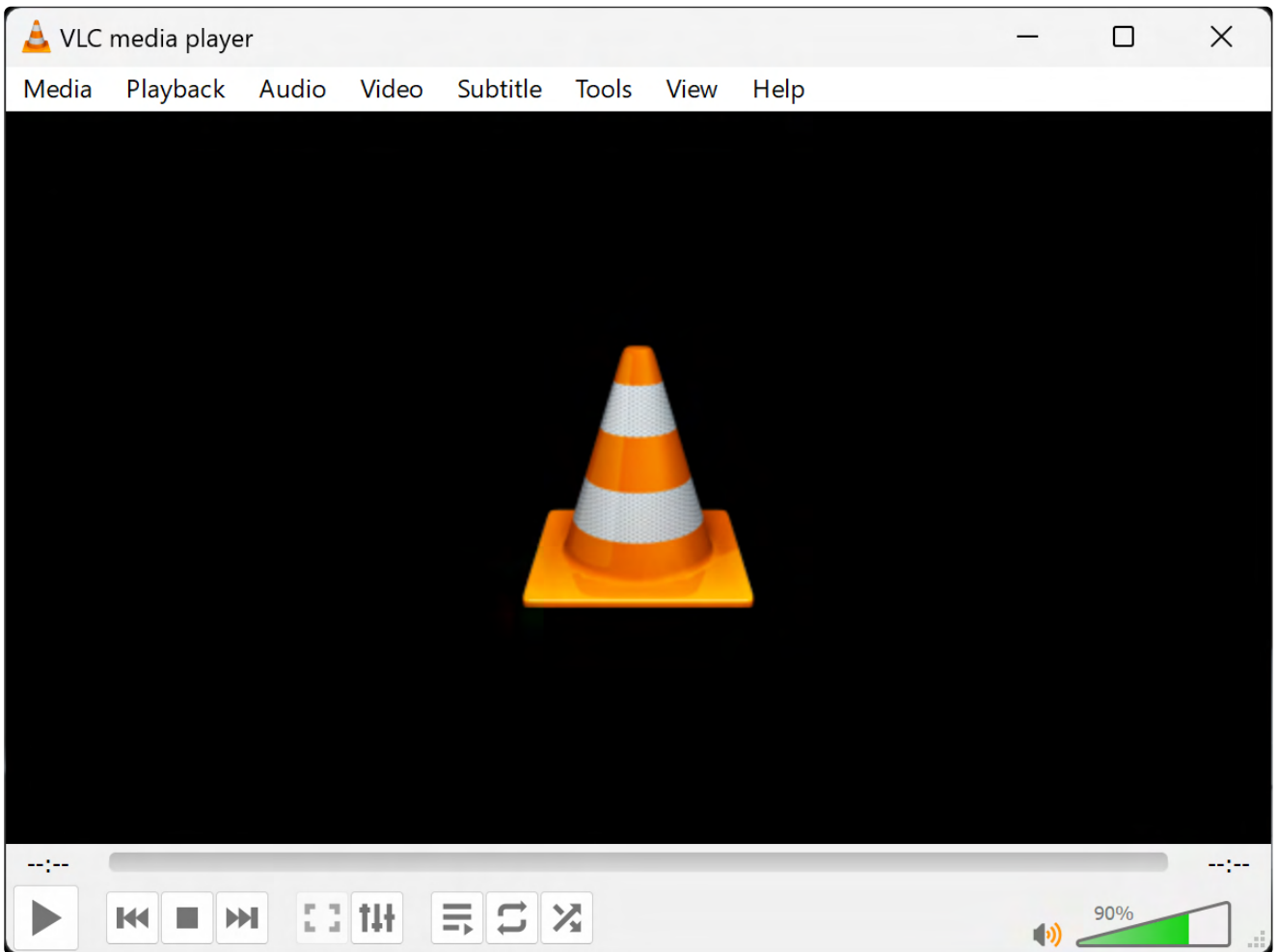

The VLC user interface might look different depending on the platform in use.

Go to "Media" and open the "Stream..." function.

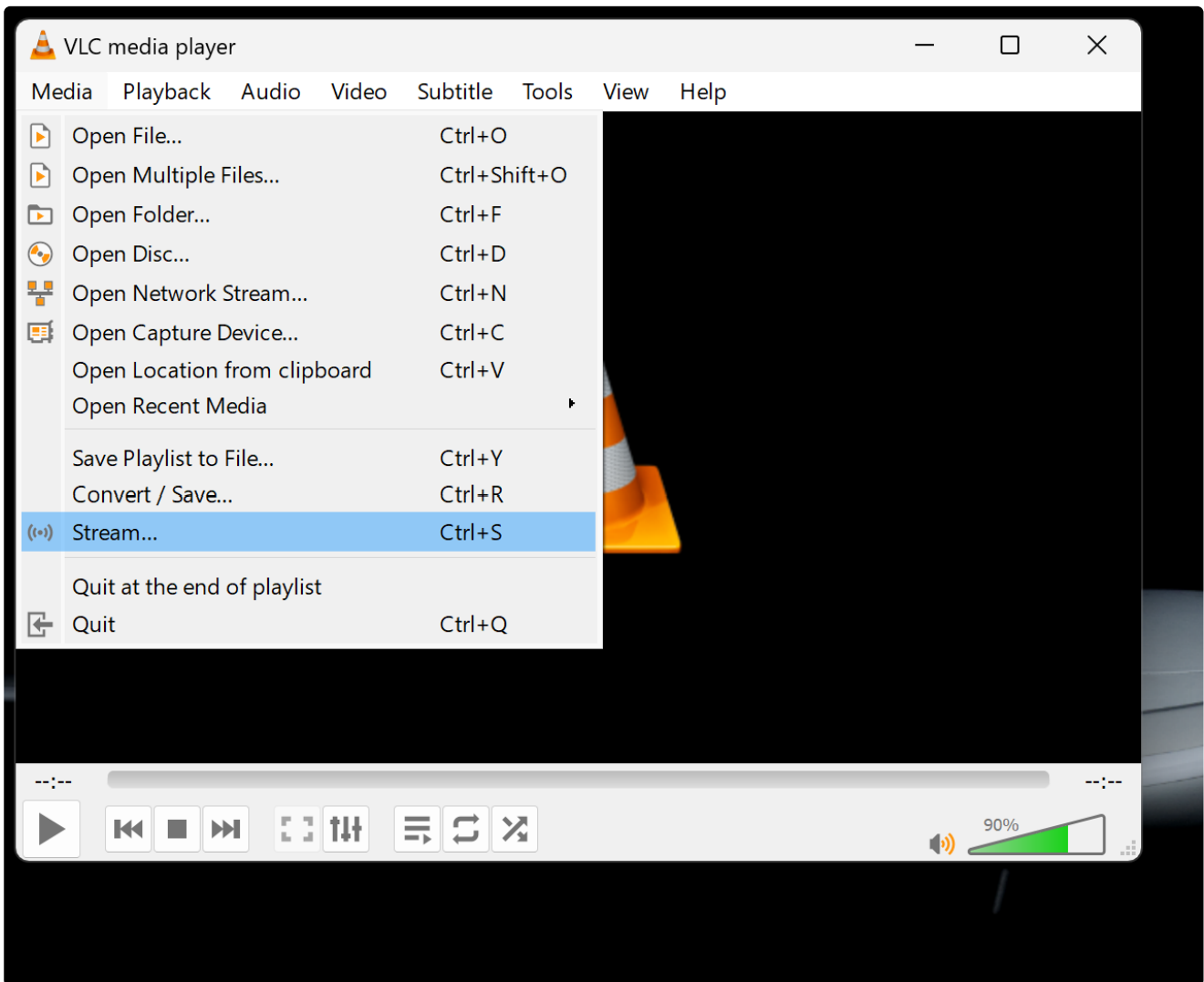

Go to the "Network" tab.

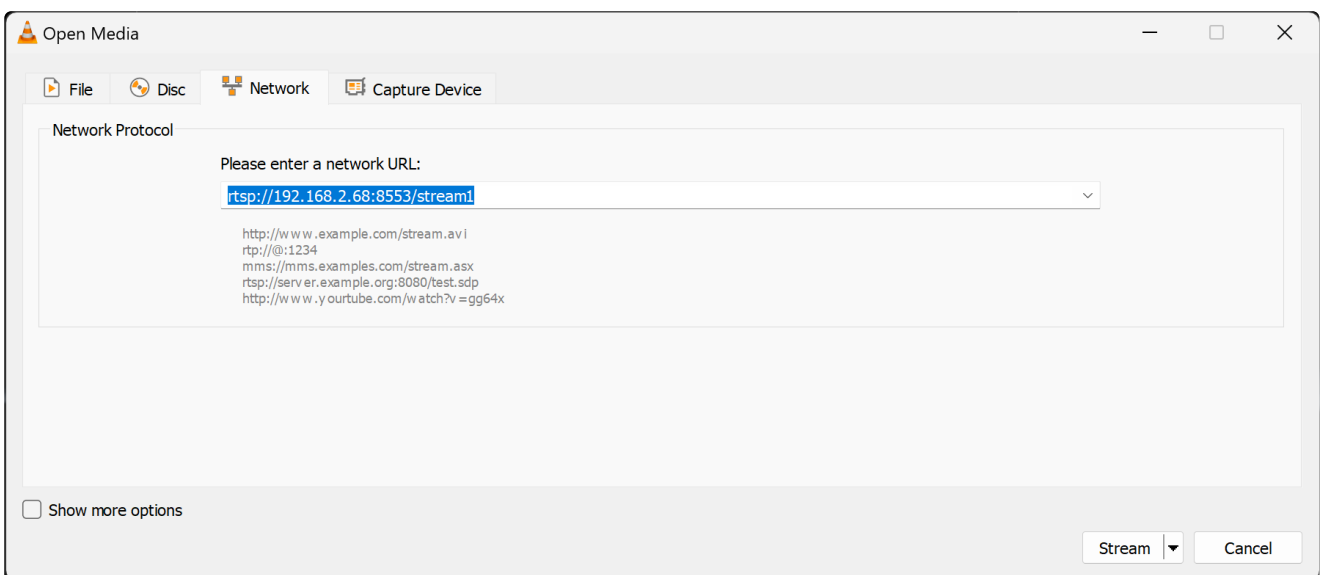

In the "network URL" field enter the following address:

```
rtsp://[IP-ADDRESS]:8553/stream1
```

In our example, it is `rtsp://192.168.2.68:8553/stream1`.

Check "Show more options" and set the value for "Caching" to 100ms. Click on "Stream" in the lower right corner of the window.

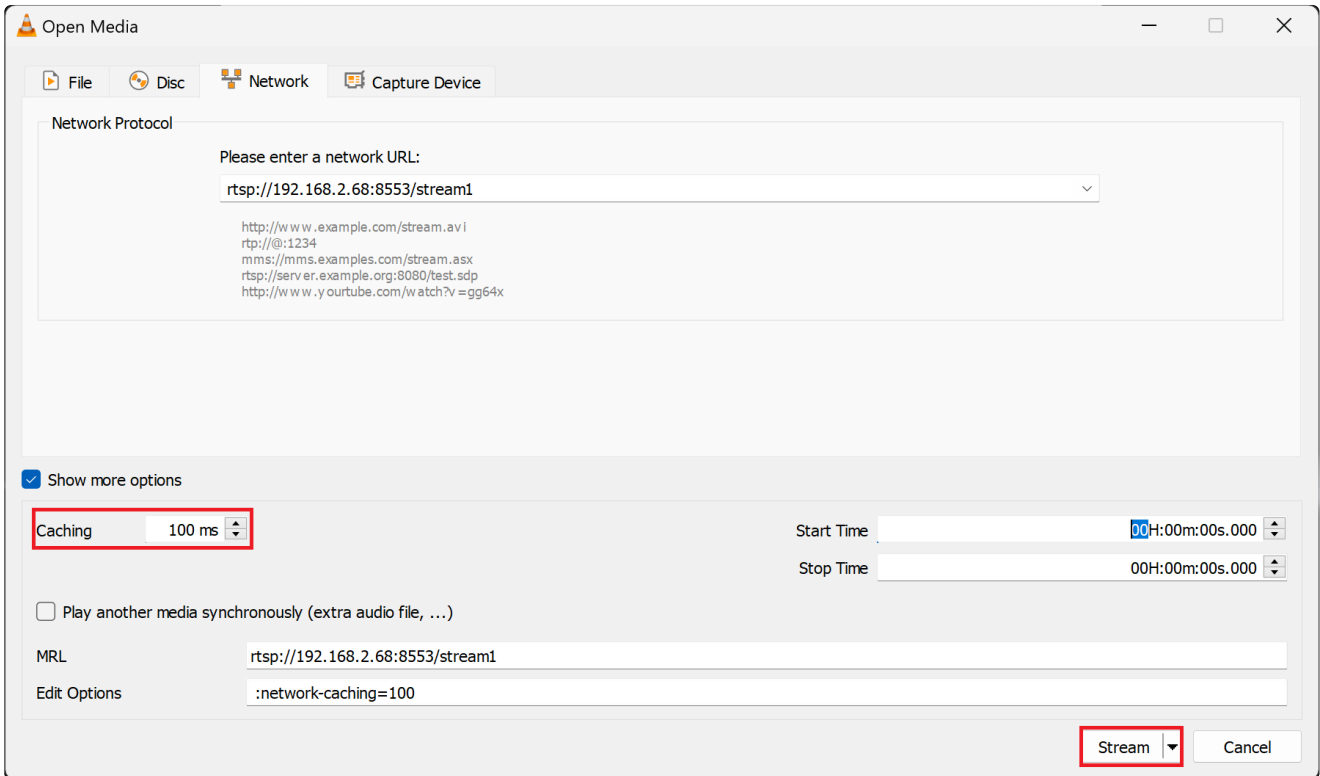

Click "Next" in the "Source" window.

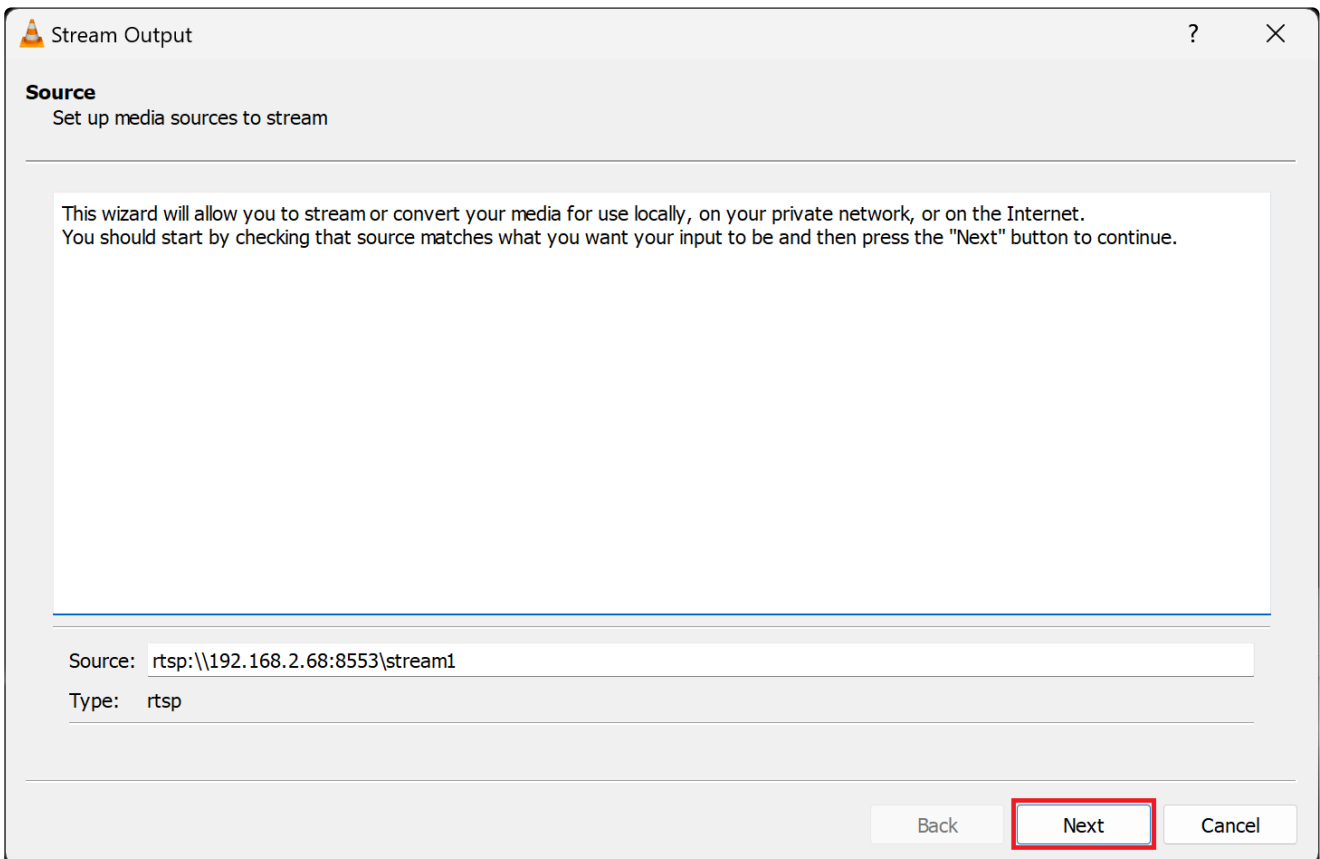

Click "Next" in the "Destination Setup" window.

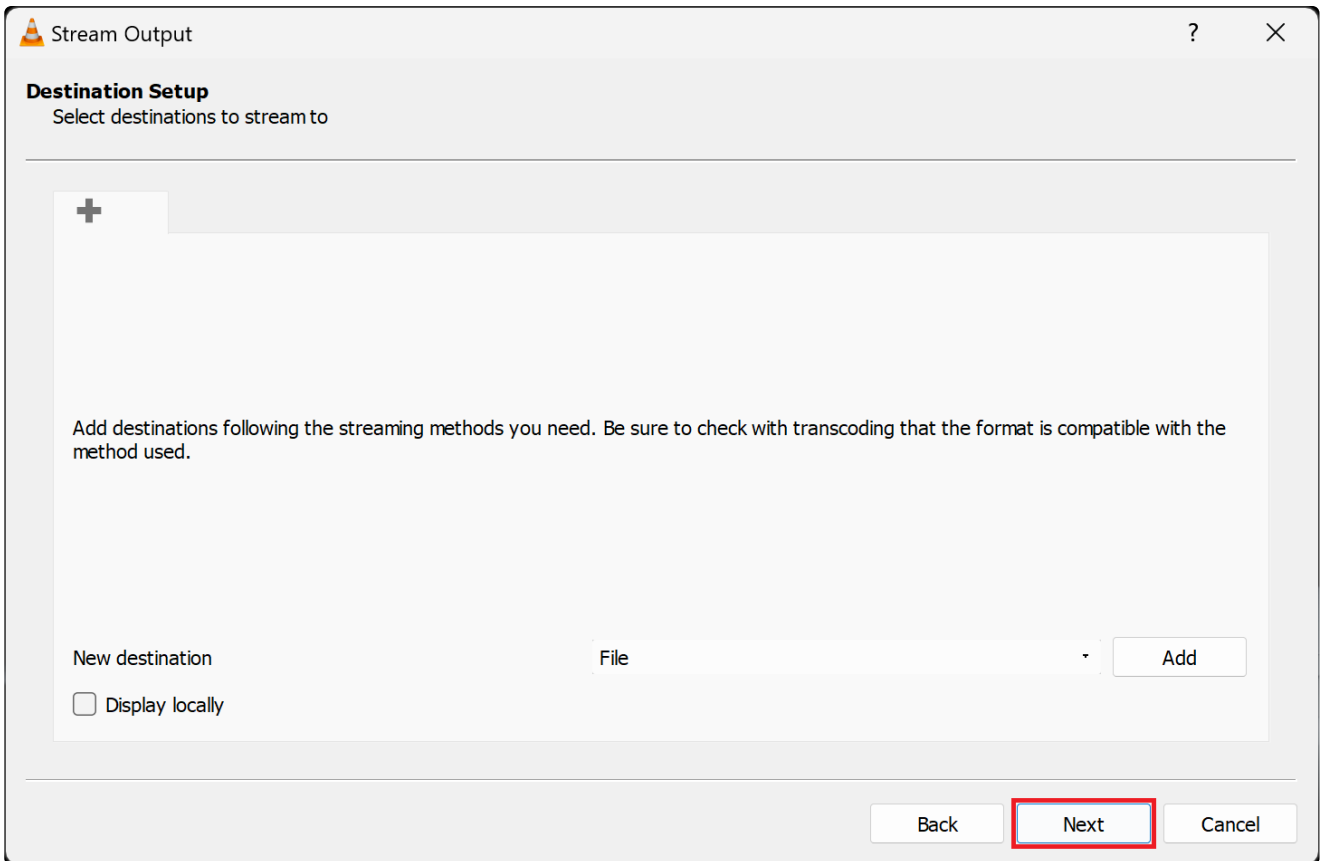

Click "Next" in the "Transcoding Options" window.

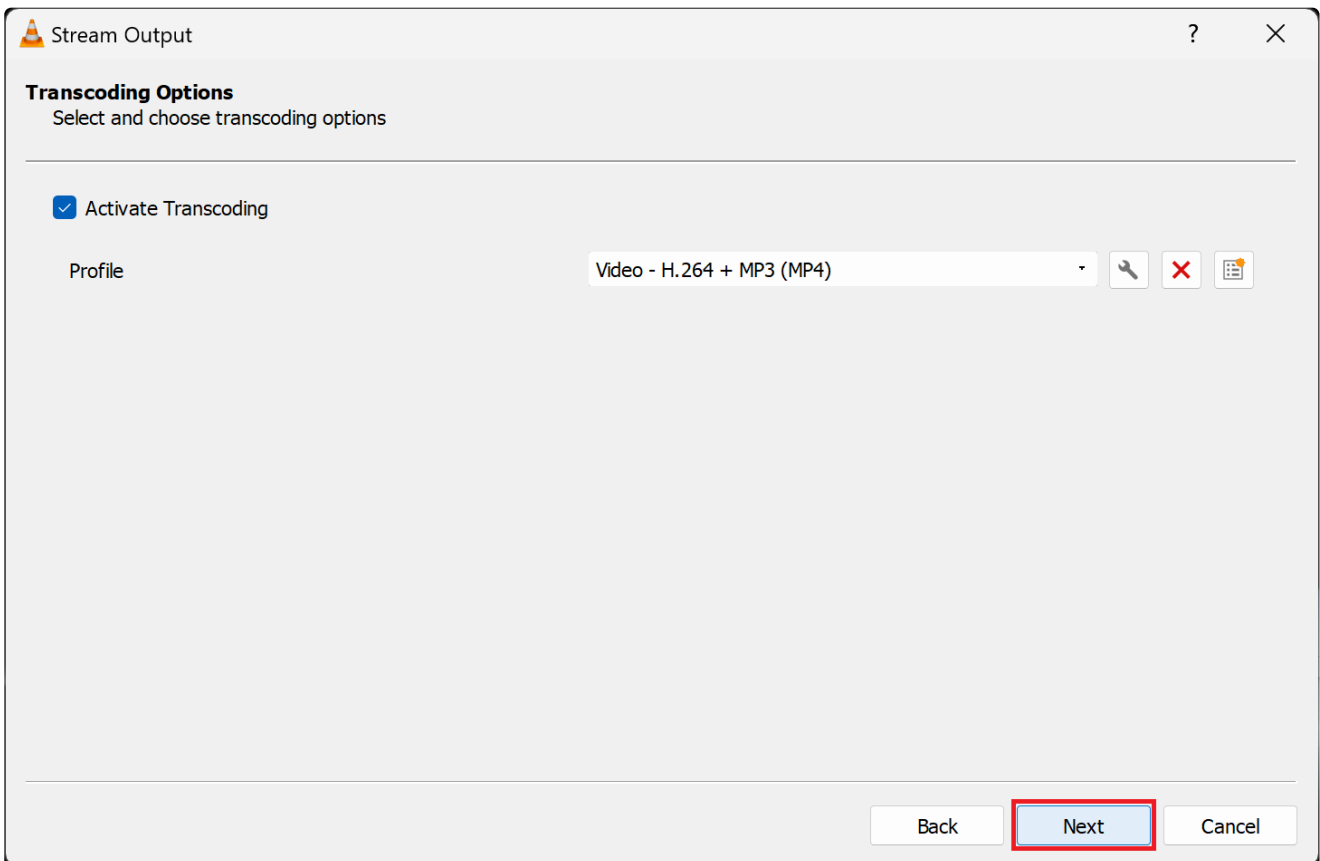

Click "Stream" in the "Option Setup" window.

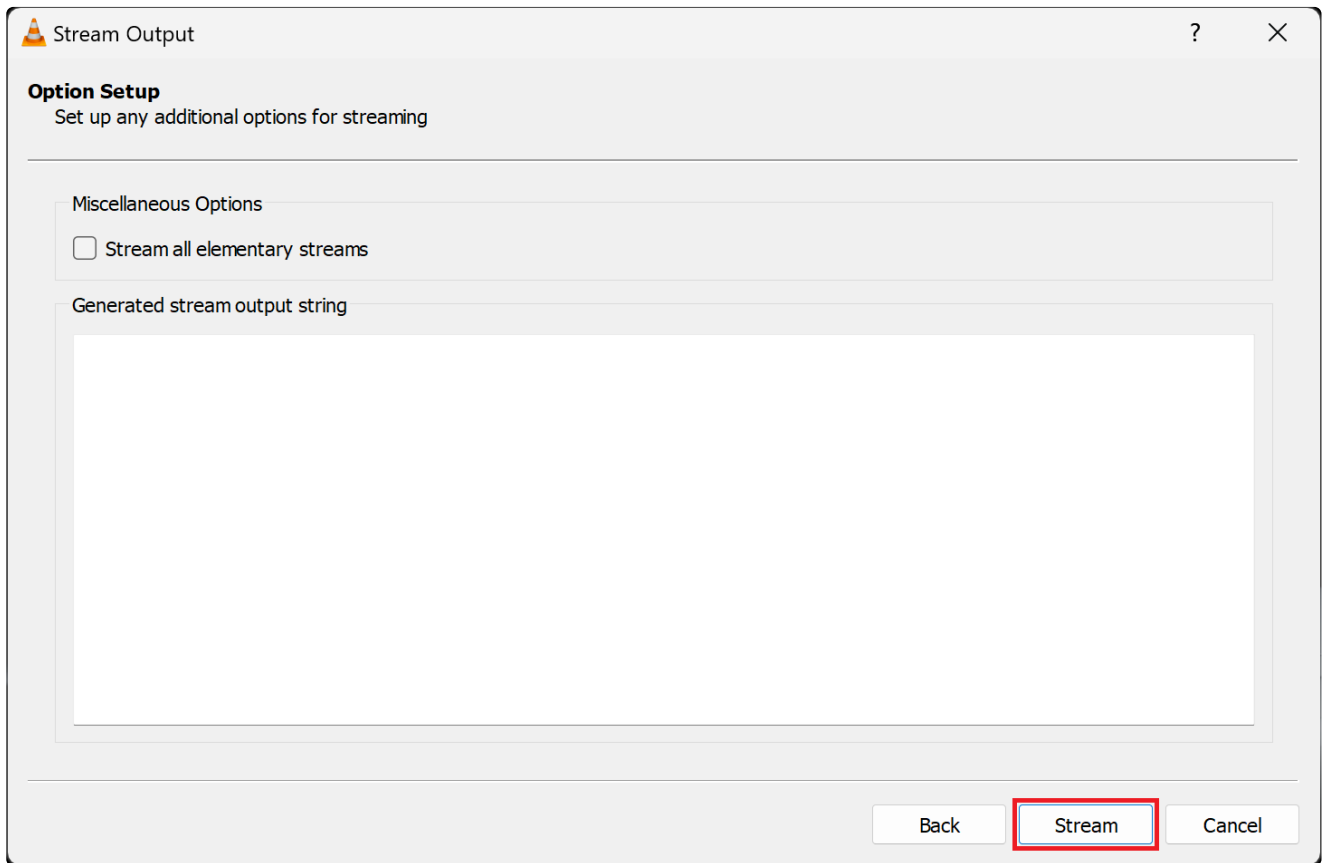

After a few seconds, the video feed should appear in the VLC Media Player.

Converting rtsp://192.168.2.68:8553/stream1 - VLC media player

Media Playback Audio Video Subtitle Tools View Help

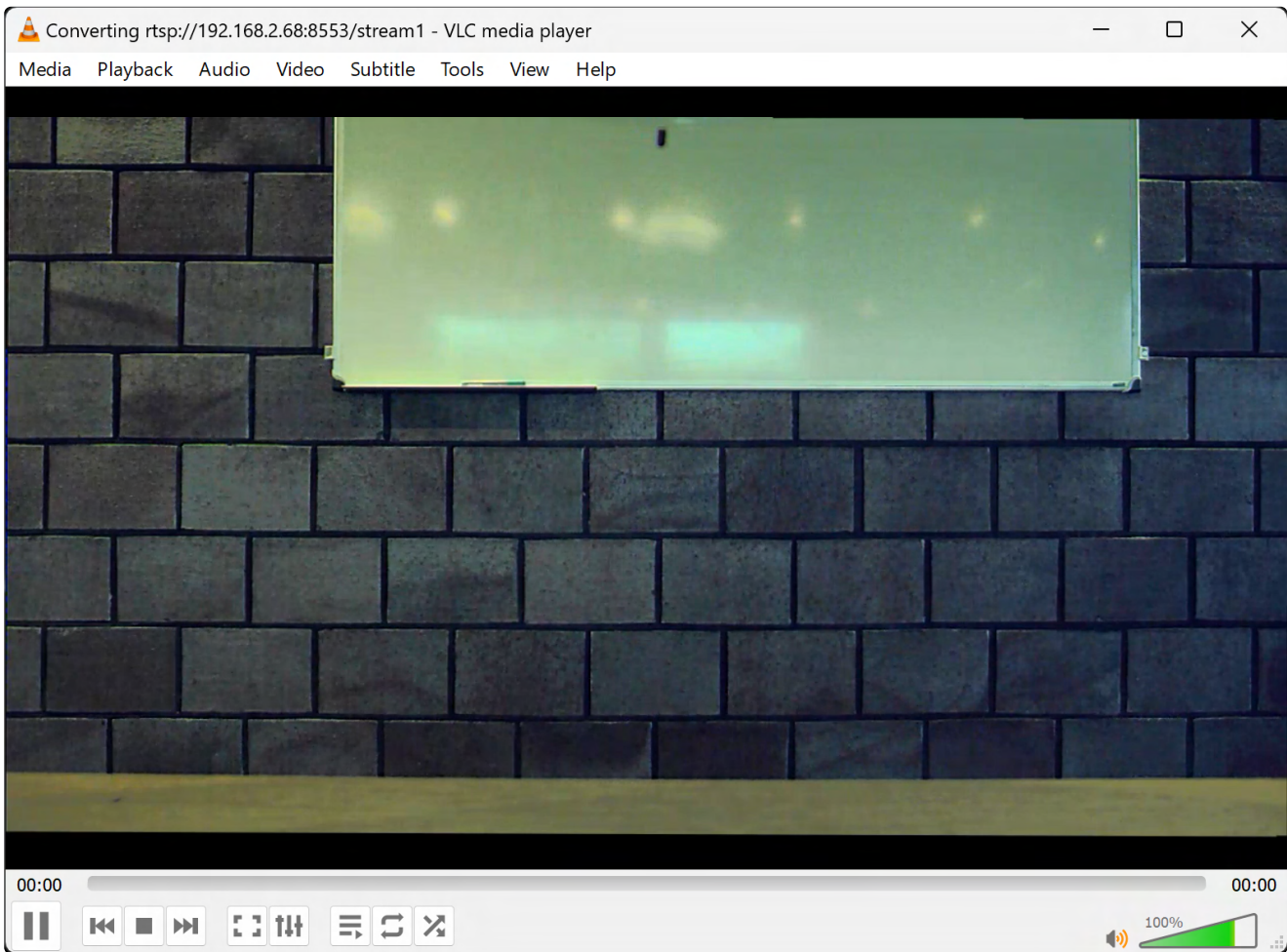

00:00 00:00

100%

The image shows a VLC media player window. The title bar reads "Converting rtsp://192.168.2.68:8553/stream1 - VLC media player". The menu bar includes "Media", "Playback", "Audio", "Video", "Subtitle", "Tools", "View", and "Help". The video content shows a whiteboard with some faint, illegible markings, mounted on a dark brick wall. The bottom of the window features a playback control bar with a progress slider (00:00 to 00:00), a set of playback controls (play/pause, stop, previous, next, full screen, playlist, extended settings, repeat, shuffle), and a volume control icon set to 100%.